

CHINO

Digital Indicating Controller

DB2000

[General]

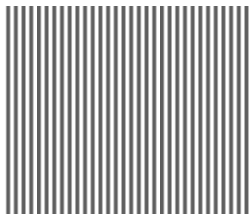

INSTRUCTIONS

CHINO

Table of Contents

1. Introduction	- 1 -	9. Operation	- 55 -
2. For safe use of the product.....	- 3 -	9-1. Confirmations before operation	- 55 -
2-1. Prerequisites for use	- 3 -	9-2. Trial operation	- 55 -
2-2. Symbol mark.....	- 3 -	9-3.RUN status and READY status	- 57 -
2-3. Important.....	- 4 -	9-4. Automatic output operation and manual output operation.....	- 57 -
3. Model code list.....	- 5 -	9-5.Precautions during operation	- 58 -
4. Mounting and wiring	- 6 -	10. Detailed explanation of main functions - 59 -	
4-1. External dimensions.....	- 6 -	10-1 Measurement range.....	- 59 -
4-2. Mounting.....	- 7 -	10-2. Linear scale	- 60 -
4-3. Wiring	- 9 -	10-3. Alarm mode.....	- 61 -
5. Name of various parts.....	- 19 -	10-4. Execution number and 8 parameters	- 68 -
5-1.Entire overview	- 19 -	10-5. Auto tuning.....	- 69 -
5-2. Overview of the front panel	- 19 -	10-6. PID control.....	- 70 -
5-3. Details of the front panel	- 20 -	10-7. Automatic PID switching system	- 71 -
6. Operation screen.....	- 21 -	10-8. Actuator adjustment of ON-OFF servo type - 72 -	
6-1. Control output and operation screen	- 21 -	10-9. Output 2	- 73 -
6-2. Operation screen of output 2 specifications.....	- 22 -	10-11.Transmission signal output.....	- 74 -
6-3. Operation screen and setting screen	- 23 -	10-10. Remote signal input	- 75 -
7. Setting screen	- 24 -	10-12. External signal input.....	- 77 -
7-1. Basics of setting	- 24 -	10-13. Communications interface.....	- 81 -
7-2. Mode 0 [Settings of parameters that are being executed].....	- 26 -	10-14. Customer scale correction.....	- 82 -
7-3.Mode 1 [Settings rated to run status].....	- 27 -	11. Engineering port	- 88 -
7-4. Mode 2 [Settings related to SV]	- 30 -	12. Trouble shooting.....	- 89 -
7-5. Mode 3 [Settings related to PID and alarm] ..	- 32 -	13. Checking and maintenance	- 91 -
7-6. Mode 4 [Settings related to output].....	- 36 -	13-1. Checking.....	- 91 -
7-7. Mode 5 [Settings related to input]	- 39 -	13-2. Life component	- 91 -
7-8. Mode 6 [Settings of transmission signal output].....	- 41 -	13-3. Disposal	- 91 -
7-9. Mode 7 [Settings related to communications] ..	- 43 -	14. Explanation of terms.....	- 92 -
7-10. Mode 11 [Settings of system].....	- 46 -	15. Accessories	- 96 -
7-11. Mode 12 [Settings of scale correction].....	- 48 -	15-1. Front protective cover	- 96 -
7-12. Initializing the setup parameter.....	- 50 -	15-2. Contact protection element.....	- 96 -
7-13. Precautions while setting	- 51 -	17. Parameter list	- 101 -
7-14. Error message	- 51 -	18. Parameter directory.....	- 105 -
8. Initial settings	- 54 -	19. Engineering unit sticker	- 107 -

1. Introduction

Thank you for purchasing Digital Indicating Controller 'DB 2000 series'.

DB 2000 series is Digital Indicating Controller with indicating accuracy of $\pm 0.1\%$, control cycle of approximately 0.1 seconds and front size of 96X96mm.

Universal input and multi SV (8 type) etc. are various functionalities that are provided as standard provisions. Besides a digital indicator with large easy to view LED display, various settings have an interactive system with high resolution dot matrix LCD display and handling is also easy with precise control.

Understand the controller properly and read this instruction manual beforehand in order to avoid any trouble.

This is a 'General' instruction manual. For specification regarding communications, read 'Communication' instruction manual along with this manual.

Request

— **For the persons doing instrumentation, installation and sales** —

Be sure to handover this instruction manual to the persons using the controller.

— **For the users of the controller** —

Preserve this instruction manual until you scrap the controller and write down the setting details.

Notices

1. You should not copy or forward fully or partially this document.
2. The contents of this document may be changed without notice.
3. We have taken enough care regarding the contents of this document however if at all you notice a mistake, contact our nearest office.
4. Please understand that regarding the result of the operation, whatever is the result the company will not be responsible.

■ Before use

After opening the pack, confirm the following before using the product. Although it is rare but if you notice anything wrong, contact your dealer or our nearest office.

1. Confirm the exterior

Confirm that the product is not broken on the outer side.

2. Confirm the model code

Confirm that the model code is that of the model that you purchase.

◆ Model code label and its location

A label as shown below is pasted on the upper surface of the controller unit.

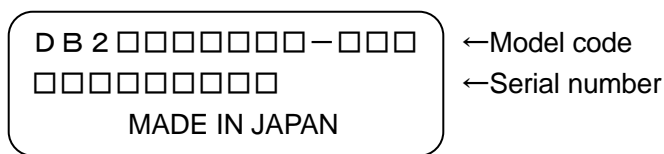

3. Confirm the accessories

The following accessories are attached to the controller, confirm them.

Name	Quantity	Remarks
Mounting bracket	2 (1 set)	For panel mounting
Contact protection element	1	Attached to ON-OFF servo type specifications only
Instruction manual (General)	1	This document
Instruction manual (Communications interface)	1	Attached to communications specifications only (in CD-R)

When accessories are requested separately, sometimes those are also attached.

Attention

1. Do not drop the instrument while taking it out of the box.
2. When transporting this instrument, pack the instrument in the box and then put it with cushions in another box. We recommend keeping the box for transport.
3. When not using the instrument for a while after taking it from the panel, put the instrument in the box and store at room temperature and in a dust free atmosphere.

2. For safe use of the product

In order to use the controller safely, read the following precautions and understand them.

2-1. Prerequisites for use



The controller is a general product of component type that is to be used by mounting it in a panel for instrumentation inside a room. Do not use it in any other condition.

When using, design a fail safe on the final product side and review regularly and use the controller after confirming the safety of the system. For the wiring, adjustment and operation of the controller contact a professional having knowledge of instrumentation.

It is necessary that the people actually using this controller read this instruction manual, and have enough understanding of various precautions and the basic operations of the controller.

2-2. Symbol mark

The following symbol marks are used in the product itself and in this instruction manual hence understand the meaning of these symbol marks properly.

Symbol mark	Meaning
 Warning	If there is a possibility of death or severe injuries then it explains the precautions to avoid that possibility.
 Precaution	If there is a possibility of small injuries or a possibility of the controller or its nearby devices getting damaged then it explains the precautions to avoid those possibilities.
	It is a symbol for ground terminal. Always connect the ground terminal to protective grounding.

2-3. Important



Warning

In order to avoid severe accidents always read these contents and understand them.

1. Confirm the power supply voltage and wiring

Before supplying the power to the instrument, check that the wiring is correct, power supply voltage matches with the rated voltage and grounding is done.

2. Install over current protection device

The controller does not have a power supply switch. Install an over current protection device (Breaker etc.) that matches the rating specifications, in the power supply of the controller.

3. Protection of terminal

To prevent electric shock provide the terminal of the controller with safety measures such that the user will not directly be able to touch the final product.

4. Installing the safety device

Regarding the use of a device that anticipates a big loss due to failure of the controller and the peripheral devices, always install a safety device for preventing these losses and implement fail safe design in the final product. Do not use it in important utilities facilities in which human life, atomic energy, aviation, space etc, are involved.

5. Do not put your hands inside the controller

Do not put your hand and tool inside the controller. You may get an injury or an electric shock.

6. Power cut off in case of suspicion

If there is an offensive smell, a strange noise or smoke or if the temperature increases abnormally, it is very risky hence cut off the power supply immediately and contact the dealer or our nearest office.

7. Prohibiting repairing and remodeling

If repairing or remodeling is necessary, contact the dealer or our nearest office. Only the service engineers appointed by our company will change the parts, do the repairing and remodeling.

8. Strictly follow the instruction manual

In order to use the controller correctly and safely, follow this instruction manual. Please understand beforehand that our company will not at all be responsible for any claims for injury, damage, and passive damages due to wrong use of the product.

3. Model code list

D B 2 ④ ⑤ ⑥ ⑦ ⑧ ⑨ ⑩ - ⑫ ⑬ ⑭

④ Input signal

- 0: Universal input
- 4: 4-wire resistance thermometer

⑤ Control mode (Output 1)

- 1: ON-OFF pulse type PID
- 2: ON-OFF servo type PID (Standard load specifications)
- 3: Current output type PID
- 5: SSR drive pulse type PID
- 6: Voltage output type PID
- 8: ON-OFF servo type PID (Very little load specifications)

⑥ Control mode (Output 2) *

- 0:None
- 1:ON-OFF pulse type PID ×1
- 3:Current output type PID ×1
- 5:SSR drive pulse type PID ×1
- 6:Voltage output type PID ×1

⑦ Zone 1 *

- 0: None
- 5:Remote signal input (4-20mA)
- 6:Remote signal input (0-1V)
- 7:Remote signal input (0-10V)
- 8: Remote signal input (Others)
- 9: Heater snapping wire alarm ×2
- P: External signal input 6 points
- M: External signal input 4 points + Heater snapping wire alarm ×2

⑧ Zone 2 *

- 0: None
- 1: Transmission signal output (High performance type: 4-20mA)
- 2: Transmission signal output (High performance type: 0-1V)
- 3: Transmission signal output (High performance type: 0-10V)
- 4: Transmission signal output (High performance type: Others)
- J: Transmission signal output (General type: 4-20mA)
- K: Transmission signal output (General type:0-1V)
- L: Transmission signal output (General type:0-10V)
- 9: Heater snapping wire alarm ×2
- P: External input signal 6 points
- M: External input signal 4 points + Heater snapping wire alarm ×2

⑨ Additional specifications of zone 2 *

- 0: None
- J: Transmission signal output 2 (General type: 4-20mA) ×3
- K: Transmission signal output, output 2 (General type: 0-1V) ×3
- L: Transmission signal output, output 2 (General type: 0-10V) ×3
- H: Transmitter power supply ×4

⑩ Zone 3 *

- 0: None
- R: Communications 1 port (RS232C) + 2 external signal inputs
- A: Communications 1 port (RS422A)
- S: Communications 1 port (RS485) + 2 external signal inputs
- B: Communications 2 port (RS232C + RS232C)
- C: Communications 2 port (RS232C + RS422A)
- D: Communications 2 port (RS232C + RS485)
- E: Communications 2 port (RS485 + RS232C)
- F: Communications 2 port (RS485 + RS422A)
- G: Communications 2 port (RS485+RS485)
- 9: Heater snapping wire alarm ×2
- P: External signal input 6 points
- M: External signal input 4 points + Heater snapping wire alarm ×2
- U: External signal input 8 points
- V: External signal input 6 points + Heater snapping wire alarm ×2

⑫ Case color

- G: Gray
- B: Black

⑬ IP54 panel sealing specifications and terminal cover *

- 0: None
- 1: Terminal cover exists
- 2: IP54 panel sealing specifications + No terminal cover
- 3: IP54 panel sealing specifications + Terminal cover exists

⑭ Power voltage

- A:100-240V (AC)
- D:24V (AC/DC)

* Option

- ×1: It can be selected when control mode (output number 1) is 1, 3, 5, or 6.
- ×2: It can be selected when control mode (output number 1) or control mode (output number 2) is 1 or 5 (pulse type).
Heater snapping wire alarm cannot overlap with other zones.
When output 1 and output 2 are both pulse type, alarm is judged output 1 side.
- ×3: It can be selected when zone 2 is 1, 2, 3, or 4.
- ×4: It can be selected when zone 2 is 0, 1, 2, 3, 4, J, K, or L

Note: Common options of zone 1,2,3 are designated priority form zone 3 ordering [9], [P], [M]

4. Mounting and wiring

4-1. External dimensions

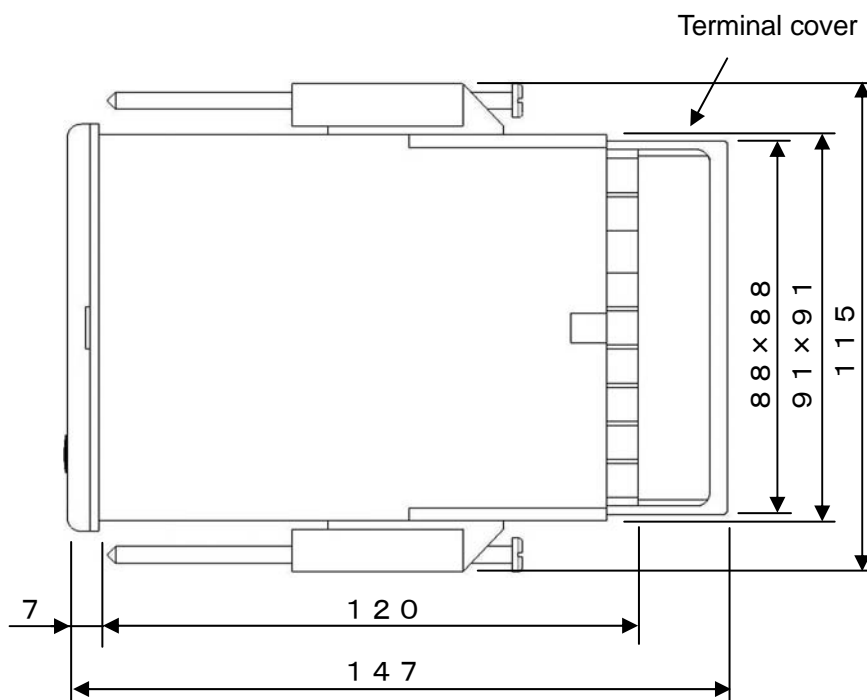
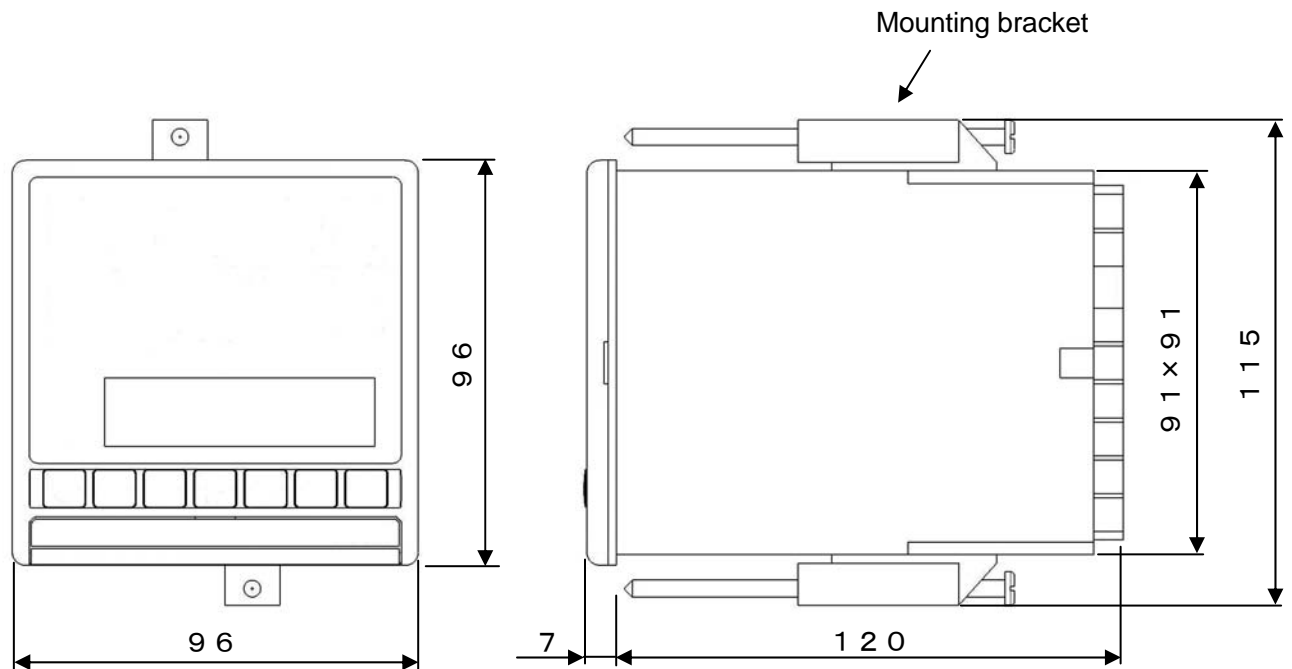

Unit: mm

4-2. Mounting

4-2-1. Panel cutout and mounting method

1. Usual mounting method

- ① Insert the controller in panel cutout.
- ② Fit in the attached mounting bracket above and below and tighten the screws with the driver and fix it. The tightening torque of the screws is '0.6 - 0.8 Nm'.
- ③ For IP54 panel sealing specifications, confirm that the gasket between product and panels is correct. Take care because if the gasket drifts or if there is a gap, the mounting is not proper and the water proofing function does not work.

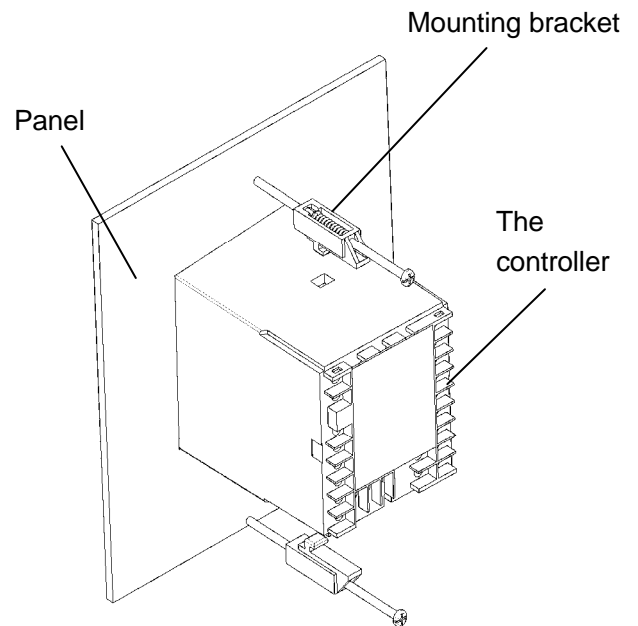
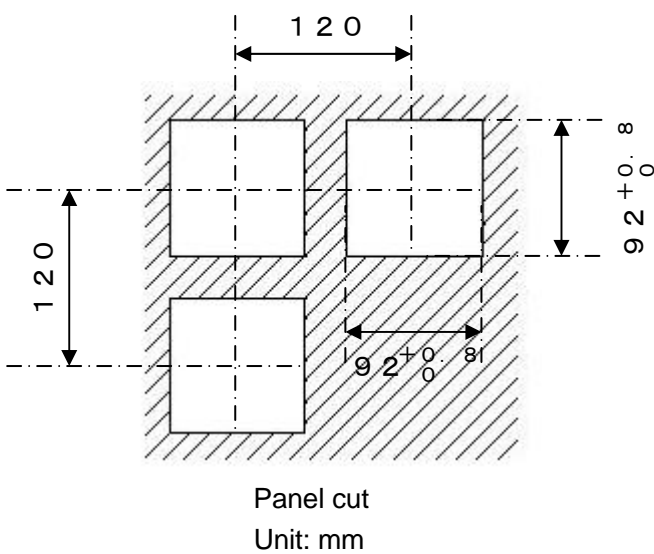

2. Closed instrumentation

- ① Insert the controller in panel cutout.
- ② Fit in the attached mounting bracket above and below and tighten the screws with the driver and fix it. The tightening torque of the screws is '0.6 - 0.8 Nm'.
- ③ At the time of closed instrumentation, in the product of IP54 panel sealing specifications, as the gasket functionality between the product and the panel is lost, water proofing functionality does not work.

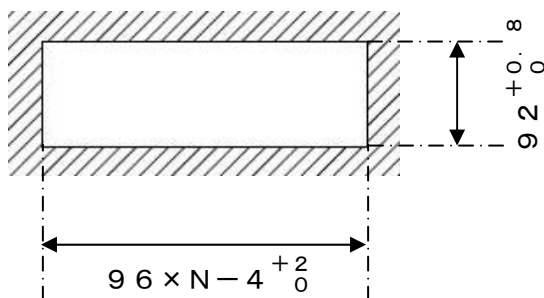

Unit: mm

N: Number of mounted instruments

4-2-2. Installation condition



Precaution

In order to avoid accidents always read and understand these contents.

1. Environment

- ① In a room.
- ② Away from direct sunlight.
- ③ Away from high temperatures.
- ④ Where there are no vibrations and shocks.
- ⑤ Away from liquids (water etc.).
- ⑥ Away from condensation.
- ⑦ Under 'Excess voltage category II , Pollution level 2' based on EN standards.

2. Atmosphere

- ① Away from strong noise, static electricity, electric field, magnetic field etc.
- ② Surrounding temperature within -10 to 50°C (Less than 40°C in case of closed instrumentation), surrounding humidity within 10-90% RH.
- ③ Variation in temperature is less.
- ④ Away from corrosive gas, explosive gas, ignition gas and combustible gas.
- ⑤ Away from salt, iron and conductive material (Carbon, iron etc.).
- ⑥ Away from steam, oil and chemicals etc.
- ⑦ Away from dust etc.
- ⑧ Away from the surroundings where high temperature is generated.
- ⑨ Away from places where temperature remains stored.
- ⑩ Lot of space above the upper part of the product.
- ⑪ Away from wind.

3. Mounting position

- ① Installation height is less than 2,000 m above the sea level
- ② Mounting position is approximately 1.5m (Approximately eye level position of a person).
- ③ Mounting orientation longitudinal tilting is less than $\pm 10^\circ$ lateral tilting is less than $\pm 10^\circ$.

4. Other

- ① Do not wipe the controller with an organic solvent (like alcohol).
- ② To avoid malfunctioning of the controller, do not use cell phones in its vicinity.
- ③ An obstacle may be created for television and radio sets placed near the controller.

4-3. Wiring

4-3-1. Terminal number and functionality

Depending on the product specifications, there are also places where terminal screw is not provided.

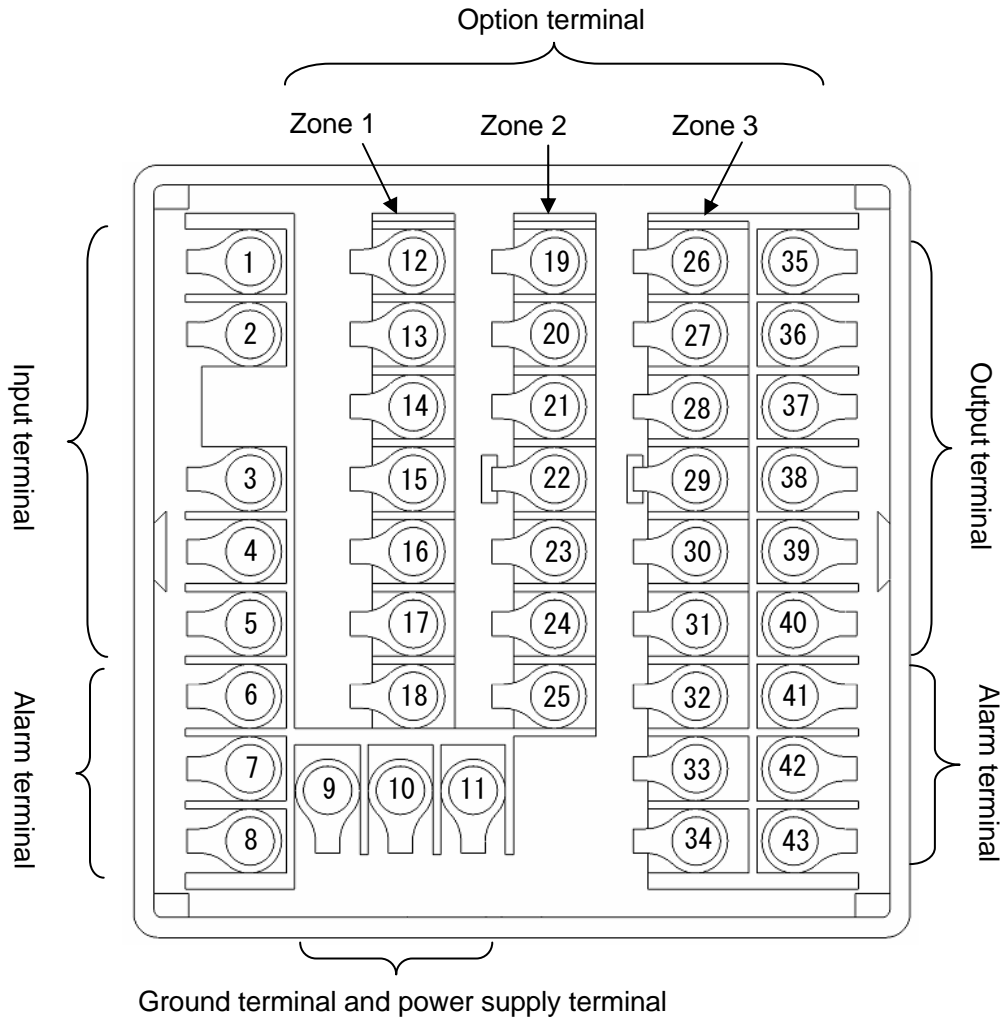

1. Power supply terminal

① General power supply specifications

Terminal number	
⑨	
⑩	
⑪	

② 24V power supply specification

Terminal number	For 24 V DC	For 24 V AC
⑨		
⑩		
⑪		

2. Input terminal

Terminal number	Thermocouple Voltage mV	Voltage V (Range No.35) (Range No.37)	Current mA (Range No.36)	Resistance thermometer (3-wire)	Resistance thermometer (4-wire)
①		⊕	⊕		Ⓐ
②	⊕			Ⓐ	Ⓐ
③	⊖	⊖	⊖	Ⓑ	Ⓑ
④				Ⓑ	Ⓑ
⑤			⊖		

Note) Do the wiring only for the specified terminals.

Note) For current mA, short circuit ③ and ⑤.

3. Output terminal

① ON-OFF pulse type

Terminal number	Internal circuit
Output 1 ③⑤ ③⑥ ③⑦	N.C. ● ———— H
	COM. ○ ———— C
	N.O. ○ ———— L
Output 2 ③⑧ ③⑨ ③⑩	N.C. ● ———— H
	COM. ○ ———— C
	N.O. ○ ———— L

② ON-OFF servo type

Terminal number	Internal circuit
③⑤	CLOSE ———— M3
③⑥	OPEN ———— M2
③⑦	COM. ———— M1
③⑧	OPEN ○ ———— R1
③⑨	COM. ———— RC
③⑩	CLOSE ———— R2

③ Current output type, SSR drive pulse type, Voltage output type

Terminal number	Current output type	SSR drive pulse type	Voltage output type
Output 1	③⑤	+	+
	③⑥	-	-
	③⑦		
Output 2	③⑧	+	+
	③⑨	-	-
	④⑩		

4. Alarm terminal

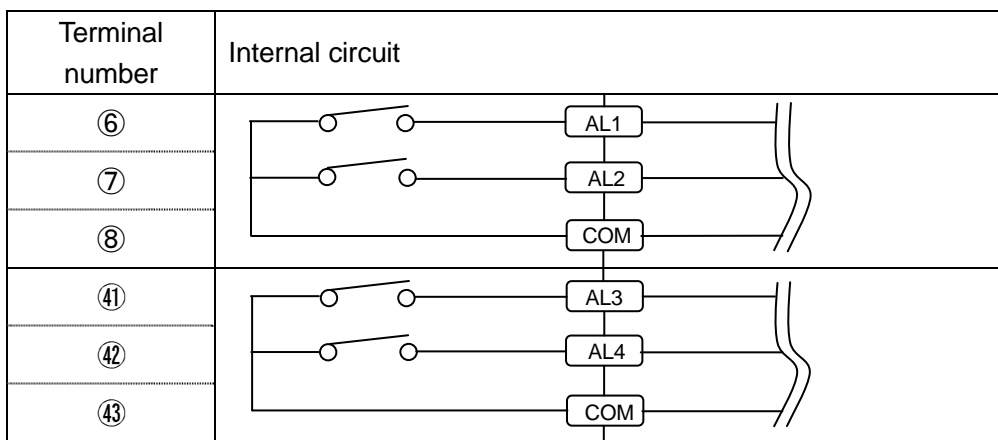

Note) Common (COM) terminal is common in AL1/AL2 and Common (COM) terminal is common in AL3/AL4.

5. Option terminal

① Zone 1

Terminal number	Remote signal input	Heater snapping wire alarm	External signal input 6 points	Heater snapping wire alarm + External signal input 4 points
①②		CT	DI	CT
①③	+	CT	DI	CT
①④	-		DI	DI
①⑤			DI	DI
①⑥			DI	DI
①⑦	Exclusively for R/L (DI)		DI	DI
①⑧	COM		COM	COM

② Zone 2

Terminal number	Transmission signal output General type	Transmission signal output High-performance	Transmission signal output Output 2 specifications		Transmitter power supply	Transmission signal output General type + Transmitter power supply		Transmission signal output High-performance type + Transmitter power supply	
			General type	High-Performance type		Transmission output	Transmitter power supply	Transmission output	Transmitter power supply
⑱	+	/	General type	+	/	Transmission output	+	/	/
⑳	-	/		-	/		-	-	/
㉑	/	+	High-Performance type	+	/	/	/	+	+
㉒	/	-		-	/	/	/	-	-
㉓	/	/	/	/	+	Transmitter power supply	+	Transmitter power supply	+
㉔	/	/	/	/	-		-		-
㉕	/	/	/	/	/	/	/	/	/

Terminal number	Heater snapping wire alarm	External signal input 6 points	Heater snapping wire alarm + External signal input 4 points
⑱	CT	DI	CT
⑳	CT	DI	CT
㉑	/	DI	DI
㉒	/	DI	DI
㉓	/	DI	DI
㉔	/	DI	DI
㉕	/	COM	COM

③ Zone 3

Terminal number	Communication RS-232C + External signal input 2 points	Communication RS-422A	Communication RS-485 + External signal input 2 points	Heater snapping wire alarm	External signal input 6 points	Heater snapping wire alarm + external signal input 4 points
⑳	RD	RDA	SA	CT	DI	CT
㉑	SD	RDB	SB	CT	DI	CT
㉒	SG	SDA	SG	/	DI	DI
㉓	DI	SDB	DI	/	DI	DI
㉔	DI	SG	DI	/	DI	DI
㉕	Exclusively for R/L (DI)	Exclusively for R/L (DI)	Exclusively for R/L (DI)	/	DI	DI
㉖	COM	COM	COM	/	COM	COM
㉗	/	/	/	/	/	/
㉘	/	/	/	/	/	/

Terminal number	Communication RS-232C (COM1) + Communication RS-232C (COM2)		Communication RS-232C (COM1) + Communication RS-422A (COM2)		Communication RS-232C (COM1) + Communication RS-485 (COM2)		Communication RS-485 (COM1) + Communication RS-232C (COM2)		Communication RS-485 (COM1) + Communication RS-422A (COM2)		Communication RS-485 (COM1) + Communication RS-485 (COM2)	
	COM1		COM1		COM1		COM1		COM1		COM1	
②⑥		RD1		RD1		RD1		SA1		SA1		SA1
②⑦	COM1	SD1	COM1	SD1	COM1	SD1	COM1	SB1	COM1	SB1	COM1	SB1
②⑧		SG1		SG1		SG1		SG1		SG1		SG1
②⑨		RD2		RDA2		SA2		RD2		RDA2		SA2
③⑩	COM2	SD2	COM2	RDB2	COM2	SB2	COM2	SD2	COM2	RDB2	COM2	SB2
③①		SG2		SDA2		SG2		SG2		SDA2		SG2
③②				SDB2						SDB2		
③③	Exclusively for R/L (DI)		Exclusively for R/L (DI)		Exclusively for R/L (DI)		Exclusively for R/L (DI)		Exclusively for R/L (DI)		Exclusively for R/L (DI)	
③④	COM		COM		COM		COM		COM		COM	

Note) There is no insulation between communication 2 ports.

Terminal number	External signal input 8 points	Heater snapping wire alarm + External signal input 6 points
②⑥	DI	CT
②⑦	DI	CT
②⑧	DI	DI
②⑨	DI	DI
③⑩	DI	DI
③①	DI	DI
③②	DI	DI
③③	DI	DI
③④	COM	COM

4-3-2. Basics of wiring

 Precaution	In order to avoid accidents always read and understand these contents.
---	--

1. Connecting to the terminal

- ① For wiring of terminal use crimp style terminal with insulating sleeve. Always use O type terminal to secure safety of power supply terminal and grounding terminal. For other types of terminals also we recommend that you use O type terminal.

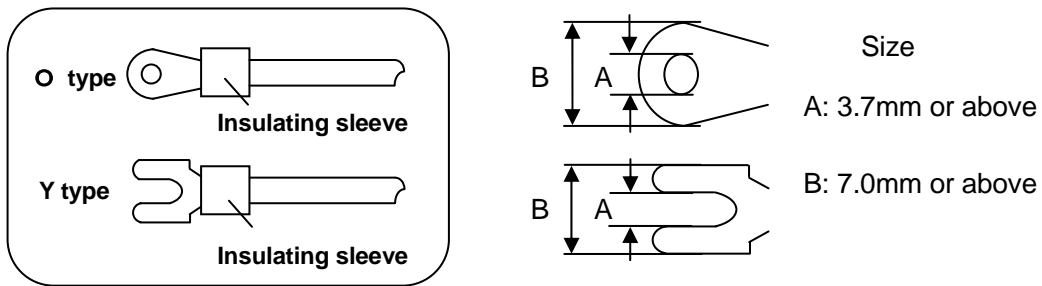

- ② When the terminal screws are tightened the torque is '0.6 - 0.8 Nm'. If a torque exceeding this value is applied, terminal screw panel gets damaged hence take care.

2. Power supply terminal

- ① In power supply, place the over current protection device and switch that conforms to the ratings of the controller within 3m so that they are easily reachable.

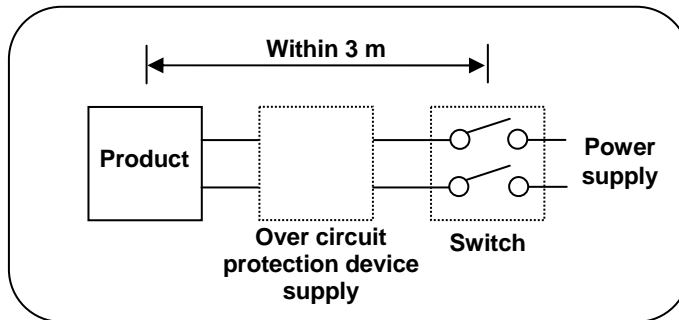

- ② Use a power supply with 600V vinyl insulation electric line (Rating more than 1A AC) and an equal to or greater electric line.
- ③ To avoid malfunctioning use good quality single phase power supply with little voltage change, wave form distortion and noise. If the noise is loud use noise filter and insert insulation transformer etc.
- ④ There is a little leakage of current flow in case of rated power supply hence take care. Leaking current is approximately 1mA.

 Warning	To avoid serious accidents always cut off the power supply and then do then wiring.
--	---

3. Input terminal

- ① Maximum permitted input of input terminal is as follows. Take care of not applying the input that exceeds these values. If an input that exceeds the range is applied, the product may get out of order or its performance may deteriorate remarkably or it may malfunction.
 - Thermocouple, voltage mV, voltage V : Less than $\pm 20V$.
 - Resistance thermometer : Less than 500Ω or Less than $\pm 5V$.
 - Current mA : Less than $\pm 30mA$ or Less than $\pm 7.5 m$.
- ② Parallel connection of input is not allowed. Not only measurement error occurs but also stable control is not performed and an error occurs in the entire system.
- ③ For thermocouple, do the wiring up to the input terminal of the product by a thermocouple or compensation lead wire.
- ④ To avoid measurement error for resistance thermometer, use cable that resistance value of each wire is equal. Take care as burn out is not provided for 4-wire resistance thermometer.
- ⑤ When connecting a protection device like zenner barrier for input protection, sometimes a big measurement error may occur. Confirm the combination with protection device and maintain the allowable signal source resistance and allowable wire resistance of the controller.

4. Output terminal

- ① Use an output terminal within the rating range. If a load that is out of range is connected, product may get out of order, its performance may show a remarkable deterioration or it may malfunction.
- ② For relay output terminal of ON-OFF pulse type and ON-OFF servo type connect the load through buffer relay. For contact protection of product internal relay and for noise reduction always insert a contact protection device on the coil side of the buffer relay. In the controller also, a small type of contact protection device is built-in for internal relay protection. Take care because a small leak current flows through this contact protection device and load voltage.
Leak current is approximately 2mA when load voltage is 200V AC and it is approximately 1mA when load voltage is 100V AC.

5. Alarm terminal

- ① Use the alarm terminal within the rating range. If a load that is out of range is applied, product may get out of order, its performance may show a remarkable deterioration or it may malfunction.
- ② For alarm terminal always connect the load through buffer relay. For contact protection of product internal relay and for noise reduction always insert a contact protection device on the coil side of the buffer relay.

6. Option terminal

- ① Use the option terminal within the rating range. If a load that is out of range is applied, product may get out of order, its performance may show a remarkable deterioration or it may malfunction.



Precaution

- ① If a power supply that is out of range is connected, product may get out of order, its performance may show a remarkable deterioration or it may malfunction.
- ② If an excess current or excess voltage is applied to input output terminal of the controller, the controller may get out of order, its performance may show a remarkable deterioration or it may malfunction.

4-3-3. Example of wiring

1. ON-OFF servo type wiring

ON-OFF servo type is connected with a motor. Refer to the terminal diagram of the motor that uses three terminals of control relay output and three terminals of feedback input and do the wiring.

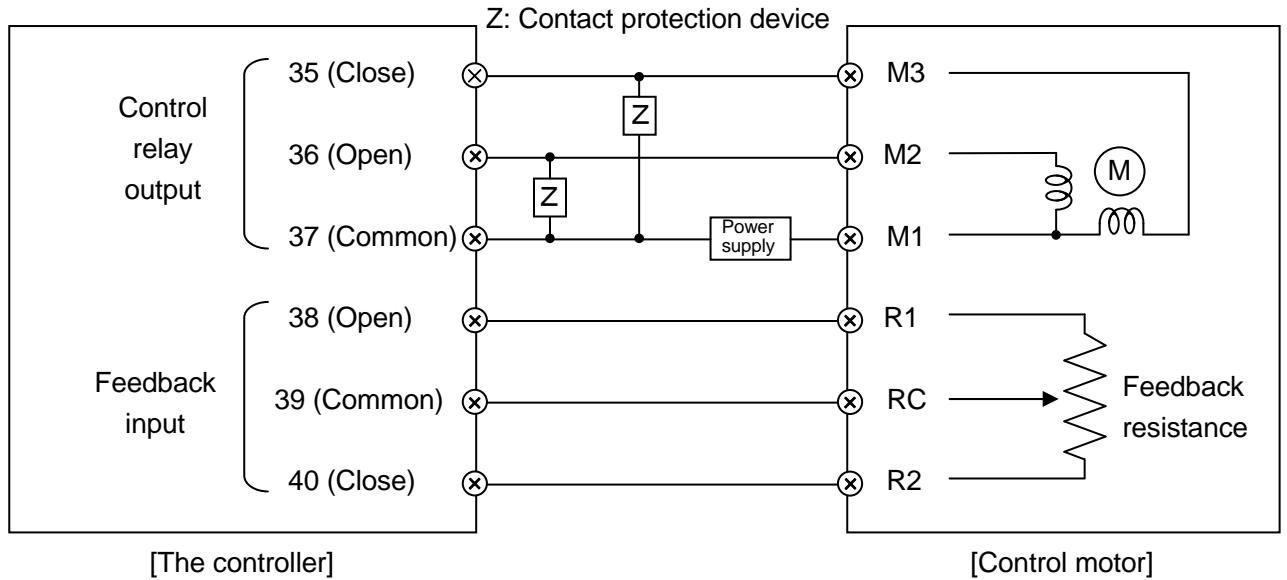

In the above diagram, the controller and control motor manufactured by our company are directly connected however, while actually connecting always insert a buffer relay and then connect. Furthermore, always connect a contact protection device in control relay output terminal.

The contact protection device attached to the controller is for the motor (For load current 700 mA and above).

When connecting with buffer relay, use a contact protection device for light load. If the attached contact protection device is used in buffer relay, operation defect occurs due to leak current.

For your reference symbolic name list of motors of various companies is given below.

Symbolic name list of motors of various companies				
Chino Products	Toho Products	Shin-Nippon Keisetsu Products	Japan Servo Products	Yamatake Products
M3	S	S	T2	1
M2	O	O	T1	2
M1	C	C	T3	3
R1	BM	B	B	Y
RC	RM	R	R	T
R2	WM	W	W	G

2. Relay output wiring example

In relay outputs like ON-OFF pulse type, ON-OFF servo type and alarm output, always connect the load through buffer relay and contact protection device.

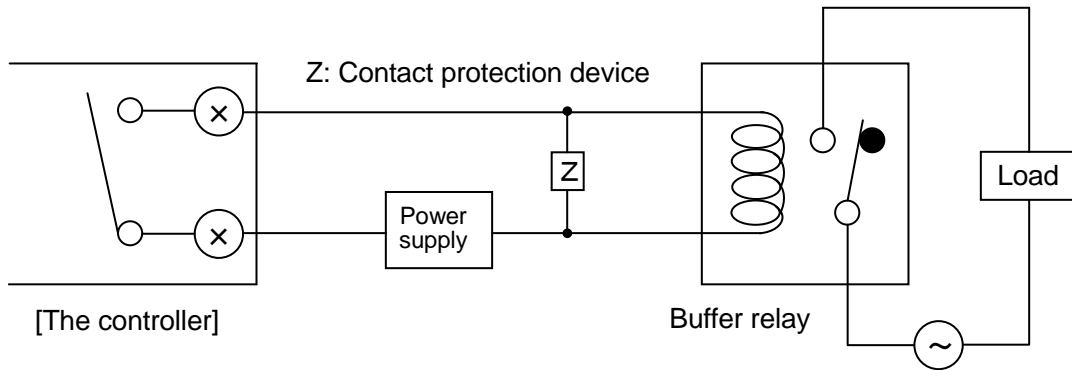

Contact protection device is handled in our company also (See 15. Accessories).

When power supply is an AC power supply CR compound device and when it is a direct current diode is generally used.

3. Wiring example of external signal input

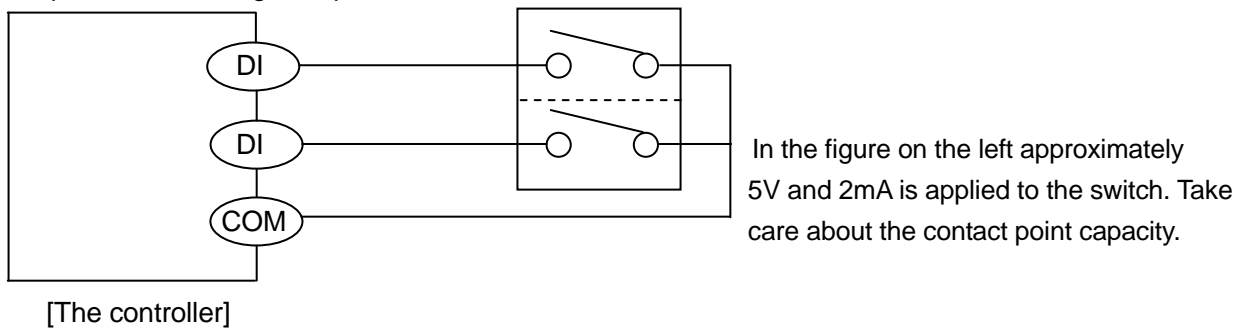

Various external signal inputs (DI) operate by short circuiting specified external signal input terminal and common (COM) terminal. Operation by switch and relay is a general method however operation by open collector output signal of peripheral device is also possible.

4. Wiring example of CT for heater snapping wire alarm

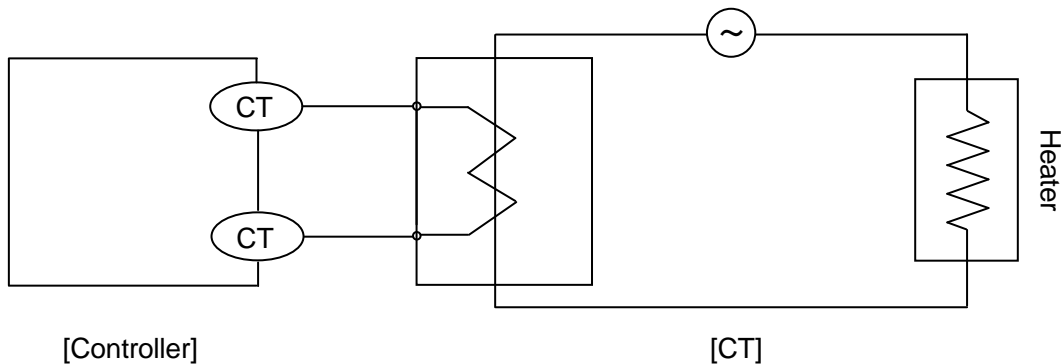

Heater snapping wire alarm judges the alarm by measuring heater current by using CT which is sold separately. Connect the electric wire to the two terminals of CT and do the wiring to the specified terminal of the controller. As for CT, customers can request it as "U-RD Company Ltd, 'CTL-12-S36-8'" directly from UR-D company.

4-3-4. Precautions while wiring



Warning

In order to avoid accidents always read and understand these contents.

1. Wiring is done by professional

Wiring is to be done by a person having actual experience and basic knowledge of instrumentation.

2. Put the terminal cover

In order to ensure safety, after the wiring is done, take measures so as to prevent direct contact with the terminal of the product.

Exclusive terminal cover of the controller is available as accessory (Sold separately).

3. Keep away from strong electric circuit and from noise source

In order to prevent adverse effect due to noise, do not place the controller near a device from which noise is generated (magnet relay, motor, thyristor regulator, inverter etc.). Also avoid passing the wiring of the controller and that of noise generating devices through the same duct. Always keep the wiring away from each other. Take the necessary countermeasures against noise.

4. Careful about connecting ground terminal

Good grounding is important for reliability of the instrument. In most cases, it is better that each instrument is connected at a point. When connected separately, it is easy to get a bad effect due to noise. Check the connecting route.

5. Keep away from heat generating sources

In order to avoid bad effect due to high temperature, do not install the controller near heat generating sources. If the controller is kept near any heat generating source, measurement goes wrong and finally the life of the product is shortened. Take care about the surrounding temperature of the product.

Avoid places where there is wind and sudden temperature change, it also causes an error in measurement.

Take necessary measures to avoid such surrounding environment.

6. Unused terminal

Do not connect anything to the unused terminal. Product may get out of order.

7. Countermeasures against erroneous output when power is supplied

When power is supplied, sometimes the output related signal may be momentarily output when the controller is starting normally. Take the necessary countermeasures by using an external circuit.

5. Name of various parts

5-1. Entire overview

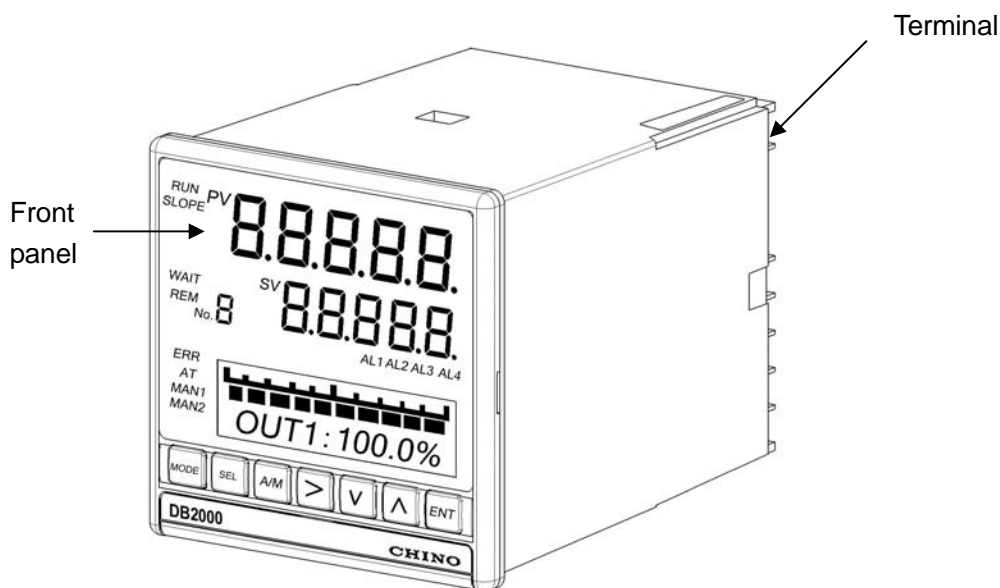

5-2. Overview of the front panel

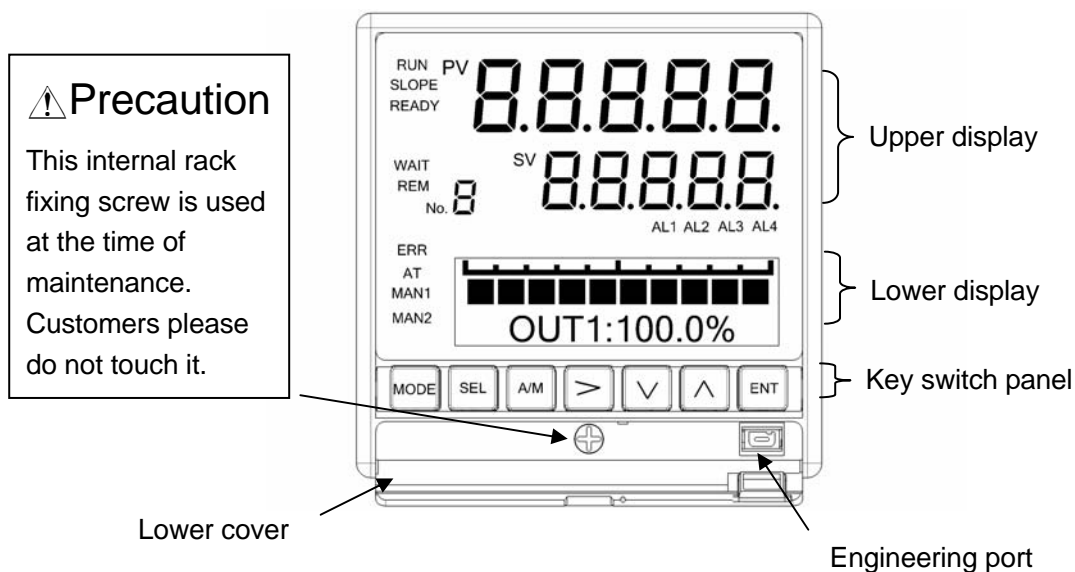

Name	Function
Upper display	Displays PV, SV and various statuses.
Lower display	Displays operation screen and settings screen.
Key switch panel	It is used for every setting. When power is supplied or any of the key is clicked key back light (blue) illuminates (At the time of initial settings). When no key operation is done for approximately 30 seconds or more, the back light goes off automatically. This back light is illuminated till the end and brightness is uneven hence the blue color has a bright part. However it does not hinder the functionality of the product hence use it as it is.
Engineering port	Settings from PC can be done after connecting the exclusive engineering cable.
Lower cover	When using engineering port open the lower cover. At other times keep it closed tightly.

5-3. Details of the front panel

5-3-1.Upper display

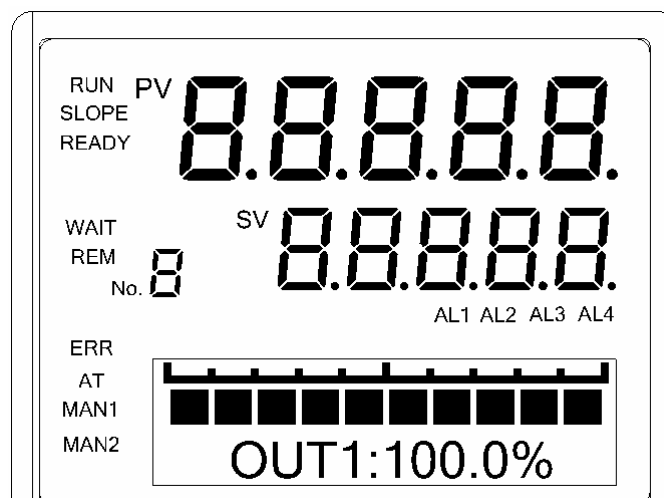

Name	Function
PV	Displays PV (measurement value).
SV	Displays SV (setting value).
No.	Displays the execution number that is being selected.
RUN	Illuminates during RUN status.
SLOPE	Illuminates during slope operation of SV.
READY	Illuminates during READY status.
WAIT	Illuminates when alarm output is released (reset). Illuminates during the wait status during the wait alarm.
REM	Illuminates during remote status. (Only for digital remote, not illuminate until remote signal is received)
ERR	Illuminates when there is an abnormality in taking in the input.
AT	Illuminates during auto tuning operation.
MAN1	Illuminates when output 1 is a manual output operation.
MAN2	Illuminates when output 2 is a manual output operation.
AL1-AL4	Illuminates when alarm from AL1 to AL4 is ON.

5-3-2. Key switch panel

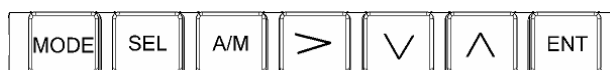



Name	Function
	It is used for changing of mode screens like operation screen and mode 0 and switching from settings screen to mode screen.
	It is used for changing the operation screen and switching of settings screen.
	It is used for changing between automatic output operation and manual output operation. This switch can be use for rewinding the cursor at setting screen.
	It is used for forwarding the cursor and for selecting a field.
	It is used in descending order of settings value (or settings field).
	It is used in ascending order of settings value (or settings field).
	It is used for registering the settings.

6. Operation screen



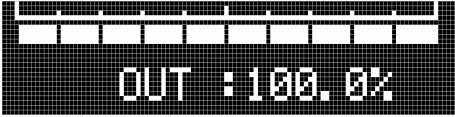

6-1. Control output and operation screen

Lower display window displays operation screen and settings screen. However the display contents of operation screen differ depending on the control output of the product.

Control output and operation screen	Description of screen
<p>[ON-OFF pulse type] [SSR drive pulse type]</p>  <p>※The above is a mock display. Actually OFF and ON do not light simultaneously.</p>	<ol style="list-style-type: none"> ① ON illuminates when output status is ON and OFF illuminates when output status is OFF. ② Displays MV (output value) digitally. ③ At the time of manual output operation (manual output) 'M' on the left of 'OUT' illuminates. ④ During PID auto tuning, 'AT' on the left of 'OUT' illuminates. ⑤ In case of specifications with heater snapping wire alarm, CT measurement value is digitally displayed by 'Existence of CT screen' of mode 1. However if it cannot be measured it displays '----'.
<p>[Current output type] [Voltage output type]</p> 	<ol style="list-style-type: none"> ① Displays a bar graph corresponding to the output value. ② Displays MV (output value) digitally. ③ At the time of manual output operation (manual output) 'M' on the left of 'OUT' gets illuminated. ④ During PID auto tuning, 'AT' on the left of 'OUT' gets illuminated.
<p>[ON-OFF servo type]</p>  <p>※ The above is a mock display. Actually CLOSE and OPEN do not illuminate simultaneously.</p>	<ol style="list-style-type: none"> ① When signal on the close side is ON CLOSE illuminates and when signal on the open side is ON OPEN illuminates. When both the signals are OFF both CLOSE and OPEN are not illuminated. ② Displays MV (output value) digitally. ③ Displays feedback value (extent of valve opening) digitally. ④ At the time of manual output operation (manual output) 'M' on the left of 'OUT' is illuminated. ⑤ During PID auto tuning, 'AT' on the left of 'OUT' is illuminated. ⑥ During FB tuning, 'AT' on the left of 'FB' is illuminated.

6-2. Operation screen of output 2 specifications

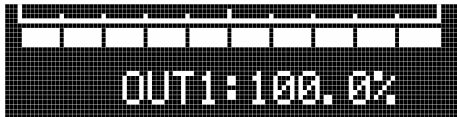
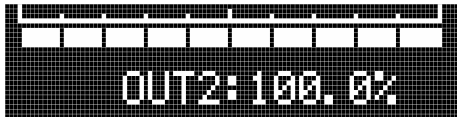
For output 2 specifications, unlike normal output 1 specifications, operation screen is displayed for each output.

Operation screen for output 1	Operation screen for output 2
<p>[ON-OFF pulse type] [SSR drive pulse type]</p> 	<p>[ON-OFF pulse type] [SSR drive pulse type]</p> 
<p>[Current output type] [Voltage output type]</p> 	<p>[Current output type] [Voltage output type]</p> 
<p>① Operation screen of output 1 becomes 'OUT1' after adding '1' on the right of 'OUT' and thus indicates that it is an operation screen for output 1. Similarly, operation screen of output 2 becomes 'OUT2' after adding '2' on the right of 'OUT' and thus indicates that it is an operation screen for output 2.</p> <p>② Switch the output 1 operation screen and output 2 operation screen by using  key.</p>	

6-3. Operation screen and setting screen



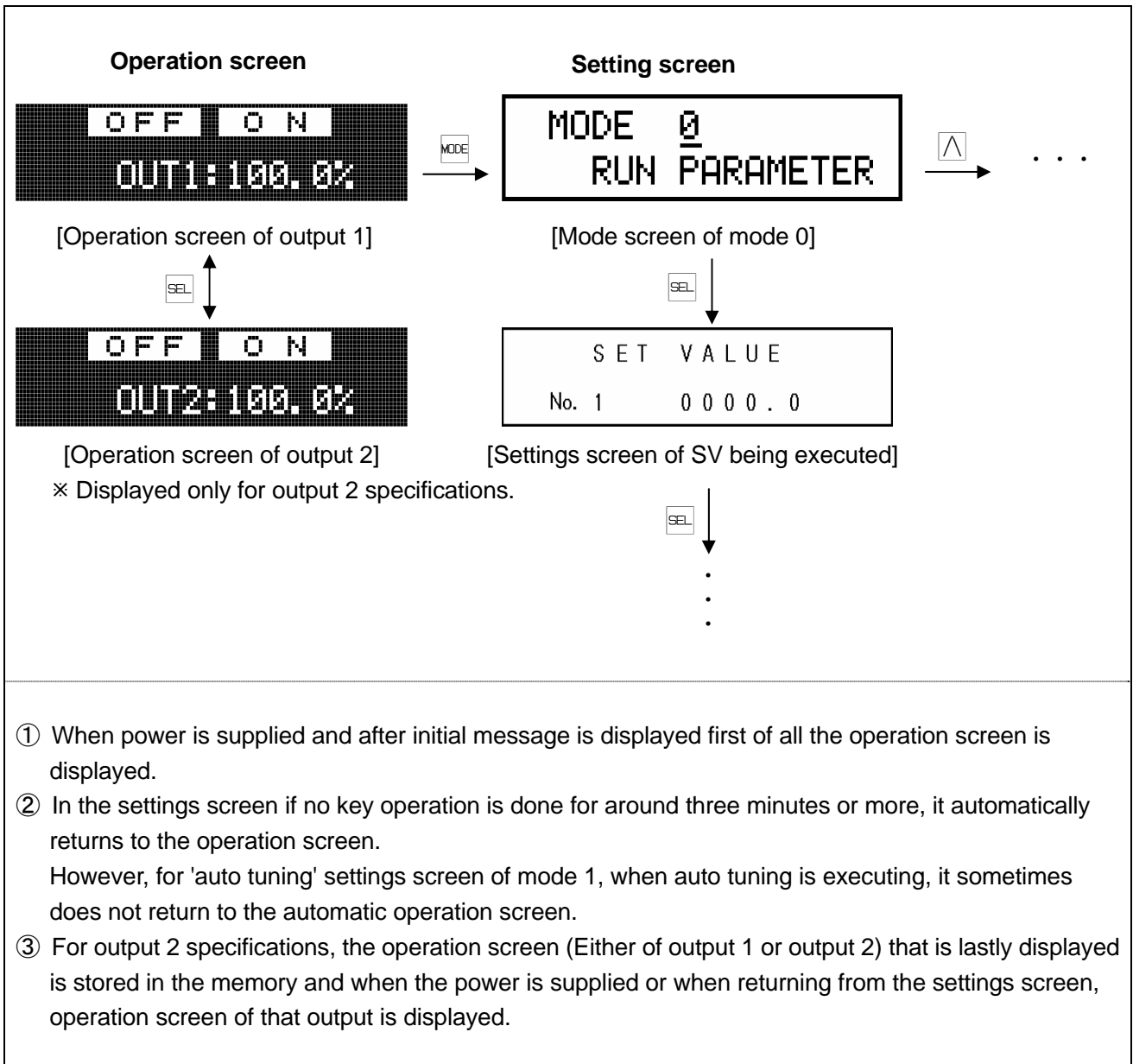

Relation between operation screen and settings screen is as follows.



7. Setting screen

7-1. Basics of setting

7-1-1. Call up the setting screen

- ① Setting screen is grouped for every mode as mentioned in '18. Parameter directory list table'. Confirm number and the mode of the settings screen that is to be call up.
- ② Switching between operation screen and mode screen is done by  key, mode screen is selected by   key and setting screen is selected by using  key from mode screen respectively.

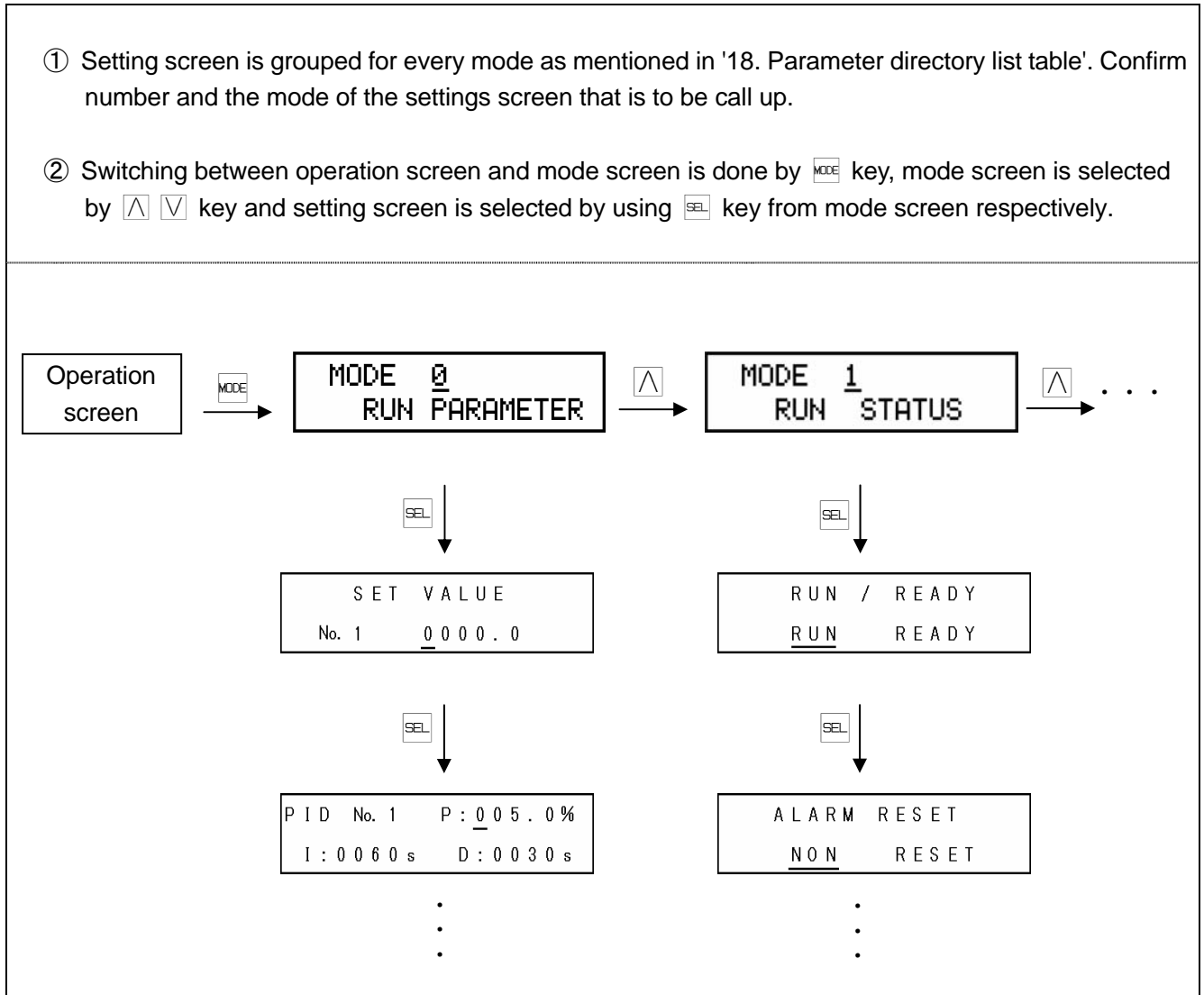

7-1-2. Basic operation of settings screen

In the settings screen, numeric value is changed and field is selected by using \triangleright \wedge \vee key and settings are completed by clicking ENT key.

Example of basic operation	
<p>1. Example of setting a numeric value</p> <div style="border: 1px solid black; padding: 5px; width: fit-content;"> PID No. 1 P : <u>0</u>05.0% I : 0060 s D : 0030 s </div>	<p>① By using \triangleright key the cursor is moved to the digit of the numeric value that is to be changed.</p> <p>② By using \wedge \vee key the desired numeric value is selected. At that time '?' mark is put.</p> <p>③ The value is registered by using the ENT key. At that time '?' mark disappears.</p>
<p>2. Example (1) of setting a field</p> <div style="border: 1px solid black; padding: 5px; width: fit-content;"> INPUT KIND 05 <u>K1</u> </div>	<p>① By using \wedge \vee key the desired field is selected. At that time '?' mark is put.</p> <p>② The field is registered by using the ENT key. At that time '?' mark disappears.</p>
<p>3. Example (2) of setting a field</p> <div style="border: 1px solid black; padding: 5px; width: fit-content;"> MEASURE UNIT °C <u>K</u> </div>	<p>① By using \triangleright key the desired field is selected. At that time '?' mark is put.</p> <p>② The field is registered by using the ENT key. At that time '?' mark disappears.</p>

A convenient key operation method is given below in order to speed up the settings operation.

<p>1. Fast forwarding the cursor</p> <p>① Usually, cursor moves by one digit by using \triangleright key, however by using the ENT key, the cursor can be moved by, set field unit.</p> <p>② For example in the following PID settings screen, when ENT key is clicked, the cursor moves as shown below.</p> <div style="text-align: center;"> <p>'No.'</p> <div style="border: 1px solid black; padding: 5px; width: fit-content;"> PID No. <u>1</u> P : 005.0% I : 0060 s D : 0030 s </div> <p style="margin-top: 10px;">\uparrow ENT</p> </div> <div style="display: inline-block; vertical-align: middle; text-align: center;"> <p>'Left most digit of the numeric value that is set, of P'</p> <div style="border: 1px solid black; padding: 5px; width: fit-content;"> PID No. 1 P : 00<u>5</u>.0% I : 0060 s D : 0030 s </div> <p style="margin-top: 10px;">\downarrow ENT</p> </div> <div style="display: inline-block; vertical-align: middle; text-align: center;"> <p>'Left most digit of the numeric value that is set, of D'</p> <div style="border: 1px solid black; padding: 5px; width: fit-content;"> PID No. 1 P : 005.0% I : 006<u>0</u> s D : 0030 s </div> <p style="margin-top: 10px;">\leftarrow ENT</p> </div> <div style="display: inline-block; vertical-align: middle; text-align: center;"> <p>'Left most digit of the numeric value that is set, of I'</p> <div style="border: 1px solid black; padding: 5px; width: fit-content;"> PID No. 1 P : 005.0% I : 00<u>6</u>0 s D : 0030 s </div> <p style="margin-top: 10px;">\leftarrow ENT</p> </div>

7-2. Mode 0

Mode 0 changes the setting of main parameters that are being executed.

Settings screen	Description of the screen
<p>1. Mode screen</p> <div style="border: 1px solid black; padding: 5px; width: fit-content; margin-bottom: 10px;"> MODE 0 RUN PARAMETER </div> <p>[Lock Status]</p> <div style="border: 1px solid black; padding: 5px; width: fit-content; margin-bottom: 10px;"> MODE 0 Lock RUN PARAMETER </div> <p>[Display off status]</p> <div style="border: 1px solid black; padding: 5px; width: fit-content;"> MODE 0 NoDisp RUN PARAMETER </div>	<p>① Mode 0 screen.</p> <p>② By clicking the  key, 'Lock' and 'NoDisp' is displayed.</p> <p>③ For mode 0 settings screen, if setting change is to be prohibited select 'Lock' .</p> <p>④ When doing the settings by communications, set all the mode screens to 'Lock' .</p> <p>⑤ When settings screen of mode 0 is not displayed, 'NoDisp' is displayed.</p>
<p>2. SV being executed</p> <div style="border: 1px solid black; padding: 5px; width: fit-content; margin: 10px auto;"> SET VALUE No. 1 0 0 0 0 . 0 </div>	<p>① SV that is being executed can be changed.</p> <p>② Setting range is within the range of SV.</p> <p>③ The change in the settings of this screen, is reflected in the set contents of '8 types SV' of mode 2.</p>
<p>3. PID being executed</p> <div style="border: 1px solid black; padding: 5px; width: fit-content; margin: 10px auto;"> PID No. 1 P : 0 0 5 . 0 % I : 0 0 6 0 s D : 0 0 3 0 s </div>	<p>① PID that is being executed can be changed.</p> <p>② The change in the settings of this screen, is reflected in the set contents of '16 types PID' of mode 3.</p>
<p>4. Alarm 1 and Alarm 2 that are being executed</p> <div style="border: 1px solid black; padding: 5px; width: fit-content; margin: 10px auto;"> ALARM AL1 / AL2 No. 1 3 0 0 0 . 0 / - 1 9 9 9 . 9 </div>	<p>① The set values of alarm 1 and alarm 2 that are being executed can be changed.</p> <p>② The change in the settings of this screen, is reflected in the set contents of 'Alarm 1 and Alarm 2' of mode 3.</p>
<p>5. Alarm 3 and Alarm 4 that are being executed</p> <div style="border: 1px solid black; padding: 5px; width: fit-content; margin: 10px auto;"> ALARM AL3 / AL4 No. 1 3 0 0 0 . 0 / - 1 9 9 9 . 9 </div>	<p>① The set values of alarm 3 and alarm 4 that are being executed can be changed.</p> <p>② The change in the settings of this screen, is reflected in the set contents of 'Alarm 3 and Alarm 4' of mode 3.</p>

7-3.Mode 1

Mode 1 performs the setting related to run status.

Settings screen	Description of the screen
<p>1. Mode screen</p> <div data-bbox="209 423 557 512" style="border: 1px solid black; padding: 5px; text-align: center;"> MODE 1 RUN STATUS </div> <p>[Lock Status]</p> <div data-bbox="209 584 557 674" style="border: 1px solid black; padding: 5px; text-align: center;"> MODE 1 Lock RUN STATUS </div> <p>[Display OFF status]</p> <div data-bbox="209 745 557 835" style="border: 1px solid black; padding: 5px; text-align: center;"> MODE 1 NoDisp RUN STATUS </div>	<ol style="list-style-type: none"> ① Mode 1 screen. ② By clicking the  key, 'Lock' and 'NoDisp' is displayed. ③ For mode 1 settings screen, if setting change is to be prohibited select 'Lock'. ④ When doing the settings by communications, set all the mode screens to 'Lock'. ⑤ When settings screen of mode 1 is not displayed, 'NoDisp' is displayed.
<p>2. Switching between RUN/READY</p> <div data-bbox="209 1066 557 1155" style="border: 1px solid black; padding: 5px; text-align: center;"> RUN / READY RUN READY </div>	<ol style="list-style-type: none"> ① You can switch between RUN and READY. ② When 'RUN' is selected, the status becomes run status and RUN in the upper display is illuminated. ③ When 'READY' is selected, RUN operation is not performed and the status is idling status. READY in the upper display is illuminated. ④ In case of specifications with external signal input, when switching between READY/RUN, by using external signal input, this setting screen selects 'RUN'. Switching is done using external signal input. <ul style="list-style-type: none"> ·External signal ON : READY status. ·External signal OFF:RUN status.
<p>3. Cancel alarm output</p> <div data-bbox="209 1503 557 1592" style="border: 1px solid black; padding: 5px; text-align: center;"> ALARM RESET NON RESET </div>	<ol style="list-style-type: none"> ① When canceling temporarily the alarm output that is activated, alarm output is cancelled when 'RESET' is set. ② At that time the cursor immediately returns to 'NON' and WAIT of upper display window illuminates. ③ In cancel (WAIT) status, once the you drift away from alarm activation condition, WAIT does not get illuminated and normal status returns. ④ Take care as the settings are common for alarm output of all the 4 points. ⑤ In case of specifications with external signal input, when canceling using external signal input, it is done by external signal ON. After cancellation immediately return the external signal to OFF.

<p>4. Switching between remote/local</p> <div data-bbox="212 253 561 342" style="border: 1px solid black; padding: 5px; text-align: center;"> LOCAL / REMOTE LOCAL REMOTE </div>	<ol style="list-style-type: none"> ① This screen is displayed if the instrument has the specifications with remote signal input or specifications with communication. ② Local SV and remote SV can be switched. ③ When 'LOCAL' is selected, perform the control action in local SV. ④ When 'REMOTE' is selected, you can perform control action in remote SV by using external remote signal (analog remote or digital remote). ⑤ 'REMOTE' is selected in this setting screen and only when external signal input (R/L) is ON, it becomes remote SV.
<p>5. Selecting execution number.</p> <div data-bbox="212 645 561 734" style="border: 1px solid black; padding: 5px; text-align: center;"> NUMBER SELECT 1 </div>	<ol style="list-style-type: none"> ① From amongst 8 types SV, the execution number of the SV to be used is set. ② The selected number is displayed on the left side of SV in the upper display window. ③ When execution number is selected using external signal input, the selection number due to external signal input is given priority and not the setting value of this setting screen.
<p>6. Auto tuning</p> <div data-bbox="212 992 561 1081" style="border: 1px solid black; padding: 5px; text-align: center;"> PID AUTO TUNING END AT1 2 3 4 </div>	<ol style="list-style-type: none"> ① Auto tuning (auto calculation) of PID is done. ② From among AT1 to 4, select the desired AT and execute it. <ul style="list-style-type: none"> ·AT1: AT (For output 1) in executing SV. ·AT2: AT (For output 1) in SV8 types for AT2 of mode 3. ·AT3: AT (For output 1) in SV8 types for AT3 of mode 3. ·AT4: AT (For output 2) in executing SV. However, AT4 can be selected only in case of output 2 specifications. ③ When auto tuning is started, AT progress status (STEP1-STEP4) is displayed. ④ If you want to stop auto tuning in between, set 'END'. ⑤ PID calculated by auto tuning can be confirmed by setting screen of each PID.
<p>7. Selecting PID No. system</p> <div data-bbox="212 1585 561 1675" style="border: 1px solid black; padding: 5px; text-align: center;"> OPERATE MODE SIMPLE MULTI </div>	<ol style="list-style-type: none"> ① Set whether to adopt a system that depends on execution number for PID that is used in auto output calculation or whether to adopt automatic PID switching system that depends on SV section. ② If 'No.1 to 8' is selected, it becomes execution number system (No. 1 to 8). ③ If 'No. 9' is selected, it becomes automatic PID switching system (No. 9). However, even if automatic PID switching system is selected, a number other than PID number operates in the execution number that is being selected.

<p>8. Selecting simple function/multiple functions</p> <div style="border: 1px solid black; padding: 5px; width: fit-content; margin: 10px auto;"> <p style="text-align: center;">O P E R A T E M O D E</p> <p style="text-align: center;">S I M P L E M U L T I</p> </div>	<ol style="list-style-type: none"> ① Switching between simple function and multiple functions can be done. ② If 'SIMPLE' is selected, it is a simple function mode and setting screen of mode 2 and onwards are not displayed. ③ If 'MULTI' is selected, it is a multiple function mode and setting screens of all the modes are displayed.
<p>9. PV hold</p> <div style="border: 1px solid black; padding: 5px; width: fit-content; margin: 10px auto;"> <p style="text-align: center;">P V H O L D</p> <p style="text-align: center;">N O N H O L D</p> </div>	<ol style="list-style-type: none"> ① Measuring PV can be held (fixed). ② If 'HOLD' is set, PV is fixed with the PV value that PV had just before the setting. ③ Status during hold is as follows. <ul style="list-style-type: none"> · Continues the control action with PV that is in hold status. · Rest everything is as per the normal operation. ④ If you want to cancel hold, set 'NON'. ⑤ When performing hold by external signal input in case of specifications with external signal input, operation of this setting screen is invalidated . (external signal input is priority) <ul style="list-style-type: none"> · External signal ON : Hold status. · External signal OFF: Cancel status.
<p>10. Operation when power supply is started</p> <div style="border: 1px solid black; padding: 5px; width: fit-content; margin: 10px auto;"> <p style="text-align: center;">P O W E R O N A C T I O N</p> <p style="text-align: center;">C O N T I N U E R E A D Y</p> </div>	<ol style="list-style-type: none"> ① Set the operation status when starting a power supply. ② If 'CONTINUE' is selected, the status is that before the power supply cut off. ③ IF 'READY' is selected, the status is ready status. ④ When 'READY' is selected and power supply is started, even though either of the setting screen or external signal input select 'RUN', the status is 'READY' status, hence take care. In that case, by returning to READY once and then to RUN again the status becomes 'RUN'.
<p>11. Existence of CT screen</p> <div style="border: 1px solid black; padding: 5px; width: fit-content; margin: 10px auto;"> <p style="text-align: center;">C T D I S P L A Y S E T</p> <p style="text-align: center;">N O N D I S P L A Y</p> </div>	<ol style="list-style-type: none"> ① Only specifications with heater wire snapping alarm are displayed. ② Set whether to display or not on the operation screen the CT measurement value for heater snapping wire judgment. ② If 'NON' is selected, CT measurement value is not displayed. ③ If 'DISPLAY' is selected, CT measurement value is displayed.

7-4. Mode 2



Mode 2 performs the setting related to SV.

Settings screen	Description of the screen
<p>1. Mode screen</p> <div style="border: 1px solid black; padding: 5px; margin-bottom: 10px;"> MODE 2 SET VALUE </div> <p>[Lock Status]</p> <div style="border: 1px solid black; padding: 5px; margin-bottom: 10px;"> MODE 2 Lock SET VALUE </div> <p>[Display OFF status]</p> <div style="border: 1px solid black; padding: 5px;"> MODE 2 NoDisp SET VALUE </div>	<p>① Mode 2 screen.</p> <p>② By clicking the \square key, 'Lock' and 'NoDisp' is displayed.</p> <p>③ For mode 2 settings screen, if setting change is to be prohibited select 'Lock'.</p> <p>④ When doing the settings by communications, set all the mode screens to 'Lock'.</p> <p>⑤ When settings screen of mode 2 is not displayed, select 'NoDisp'.</p>
<p>2. 8 types SV</p> <div style="border: 1px solid black; padding: 5px; margin-top: 10px;"> SET VALUE No. 1 0000.0 </div>	<p>① Set 8 types of SV.</p> <p>② Number 1 to 8 corresponds to execution number 1 to 8.</p> <p>③ Setting range is within the SV range.</p> <p>④ When measurement range, unit, measurement scope, linear scale etc is changed, sometimes the setting range and decimal point position changes automatically and relatively hence take care.</p>
<p>3. SV change rate</p> <div style="border: 1px solid black; padding: 5px; margin-top: 10px;"> SV UP: 0000.0 SLP DW: 0000.0 / M </div>	<p>① When SV is changed, slope operation can be stored in SV.</p> <p>② Change rate (for every unit time) of ascending SV is set in 'UP' and change rate (for every unit time) of descending SV is set in 'DW'. Time unit is common for 'UP' and 'DW', and is selected from 'H': hours, 'M': minutes, 'S': seconds.</p> <p>③ Conditions for SV change rate to be valid are as follows.</p> <ul style="list-style-type: none"> ▪ At the time of starting the power supply. ▪ When set value of executing SV is changed. ▪ When SV is changed on changing the execution number. ▪ When the execution number is changed. ▪ When switching from manual output operation to automatic output operation. ▪ When switching from READY status to RUN status. ▪ When switching from remote SV to local SV. <p>※ But when switching from local SV to remote SV, SV change rate is not operate.</p> <p>④ When returning from power failure or switching from manual output operation to automatic output operation it becomes PV start operation.</p> <p>⑤ During slope operation, sloping SV is displayed in upper display window and 'SLOPE' illuminates, indicating that slope operation is being performed.</p> <p>⑥ When SV change rate is to be disabled, set UP and DW as '0'.</p> <p>⑦ When measurement range, unit, measurement scope, linear scale etc is changed, sometimes decimal point position changes automatically and relatively hence take care.</p>

<p>4. SV range</p> <div style="border: 1px solid black; padding: 5px; text-align: center;"> S V L I M I T L - 0 2 0 0 . 0 H 1 3 7 0 . 0 </div>	<ol style="list-style-type: none"> ① Set the setting range of SV. ② Setting range is within the measurement range (including linear scale). ③ When measurement range, unit, measurement scope, linear scale etc is changed, sometimes setting range and decimal point position changes or it is initialized automatically and relatively hence take care.
<p>5. Remote scale</p> <div style="border: 1px solid black; padding: 5px; text-align: center;"> R E M O T E S C A L E - 0 2 0 0 . 0 ~ 1 3 7 0 . 0 </div>	<ol style="list-style-type: none"> ① Only the specifications with remote signal input are displayed. ② Set the scale corresponding to remote signal input (analog signal). ③ Set lower limit value (0%) of the scale for minimum value (0%) of remote signal input and higher limit value (100%) for maximum value (100%) of remote signal input. ④ When measurement range, unit, measurement scope, linear scale etc is changed, sometimes setting range and decimal point position changes or it is initialized automatically and relatively hence take care.
<p>6. Remote shift 8 types</p> <div style="border: 1px solid black; padding: 5px; text-align: center;"> R E M O T E S H I F T No. 1 0 0 0 . 0 0 </div>	<ol style="list-style-type: none"> ① This screen is displayed if the instrument has the specifications with remote signal input or specifications with communications. ② 8 types of shift (Bias) values of remote SV are set. ③ Numbers 1 to 8 correspond to execution numbers 1 to 8. ④ When measurement range, unit, measurement scope, linear scale etc is changed, sometimes decimal point position changes automatically and relatively hence take care.
<p>7. Remote filter</p> <div style="border: 1px solid black; padding: 5px; text-align: center;"> R E M O T E F I L T E R 0 0 . 0 s </div>	<ol style="list-style-type: none"> ① This screen is displayed if the instrument has the specifications with remote signal input or specifications with communications. ② First-order lag operation is done in remote SV. This function is enabled when flat key in external remote signal input (analog signal) is large.
<p>8. Cascade constant</p> <div style="border: 1px solid black; padding: 5px; text-align: center;"> C A S C A D E r : 1 . 0 0 b : 0 0 0 . 0 % </div>	<ol style="list-style-type: none"> ① Only specifications with remote signal input are displayed. ② This function is used when performing cascade operation as secondary regulator of cascade control loop. ③ Ratio is set in 'r' and bias is set in 'b'.
<p>9. Existence of tracking</p> <div style="border: 1px solid black; padding: 5px; text-align: center;"> L O C A L O N T R A C K O N O F F </div>	<ol style="list-style-type: none"> ① This screen is displayed if the instrument has the specifications with remote signal input or specifications with communications. ② It is a function that changes remote SV just before the switching, to local SV (copy) when switching from remote SV to local SV. ③ Generally as there is a deviation in SV at the time of switching, the control gets disturbed, however by using this function it can be suppressed. ④ If you want to enable tracking, set it to 'ON'.

7-5. Mode 3

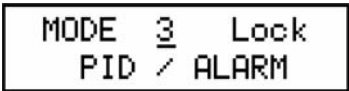
Mode 3 performs the setting related to PID and alarm.

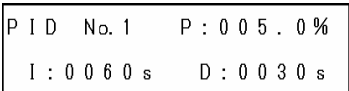
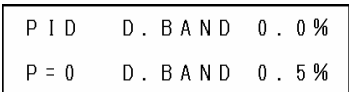
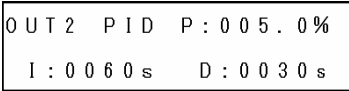
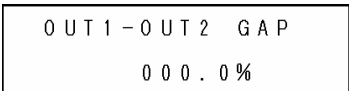
Settings screen	Description of the screen
<p>1. Mode screen</p>  <p>[Lock Status]</p>  <p>[Display OFF status]</p> 	<p>① Mode 3 screen.</p> <p>② By clicking the  key, 'Lock' and 'NoDisp' is displayed.</p> <p>③ For mode 3 settings screen, if setting change is to be prohibited select 'Lock'.</p> <p>④ When doing the settings by communications, set all the mode screens to 'Lock'.</p> <p>⑤ When settings screen of mode 3 is not displayed, select 'NoDisp'.</p>
<p>2. 16 types PID</p> 	<p>① Set all 16 types of PIDs from number 1 to 8 and number 9-1 to 9-8.</p> <p>② Numbers 1 to 8 correspond to execution numbers 1 to 8.</p> <p>③ Numbers 9-1 to 9-8 correspond to automatic PID conversion system.</p> <p>④ By setting P as 0%, two-position control operates.</p> <p>⑤ When I is set in 0s, it is equivalent to ∞. When D is set in 0s, it is equivalent to OFF.</p>
<p>3. Output dead band</p> 	<p>① Set output dead band.</p> <p>② Set PID dead band in 'PID D.BAND' of upper row, and output dead band of two-position control action (When P=0%) in 'P=0 D.BAND' of the lower row respectively.</p> <p>③ PID dead band non-linearises the deviation in the dead band and slows down the response of control output.</p> <p>④ Output dead band of two-position control action becomes the dead band at the time of output ON/OFF.</p>
<p>4. Output 2 PID</p> 	<p>① Output 2 specification and output 2 control system are displayed only at the time of selecting 'PID system'.</p> <p>② Set PID for output 2.</p>
<p>5. Output 2 gap</p> 	<p>① Output 2 specifications and output control system are displayed only when 'PID system' is selected.</p> <p>② Gap between output1 and output 2 is set.</p>

<p>6. Output 2 dead band</p> <div style="border: 1px solid black; padding: 5px; margin: 10px 0;"> <p>OUT 2 D. BAND 0.0%</p> <p>P=0 D. BAND 0.5%</p> </div>	<ol style="list-style-type: none"> ① Output 2 specifications and output 2 control system are displayed only when 'PID system' is selected. ② Set output dead band for output 2. ③ Set PID dead band in 'D.BAND' of upper row, and output dead band of two position control action (When P=0%). in 'P=0 D.BAND' of lower row respectively. ④ PID dead band non-linearises the deviation in dead band and slows the response of control output. ⑤ Output dead band of two-position control action becomes a dead band at the time of output ON/OFF. 		
<p>7. Alarm 1 and Alarm 2</p> <div style="border: 1px solid black; padding: 5px; margin: 10px 0;"> <p>ALARM AL1/AL2 No. 1</p> <p>3000.0 / -1999.9</p> </div>	<ol style="list-style-type: none"> ① Set 8 types of settings values of alarm 1 and alarm 2. ② Numbers 1 to 8 correspond to execution numbers 1 to 8. ③ When FAIL is selected in alarm format, 'FAIL' is displayed and setting cannot be done. ④ When measurement range, unit, measurement scope, linear scale, alarm format etc is changed, sometimes setting range and decimal point position changes automatically and relatively hence take care. 		
<p>8. Alarm 3 and Alarm 4</p> <div style="border: 1px solid black; padding: 5px; margin: 10px 0;"> <p>ALARM AL3/AL4 No. 1</p> <p>3000.0 / -1999.9</p> </div>	<ol style="list-style-type: none"> ① Set 8 types of settings values of alarm 3 and alarm 4. ② Numbers 1 to 8 correspond to execution numbers 1 to 8. ③ When FAIL is selected in alarm format, 'FAIL' is displayed and setting cannot be done. ④ When measurement range, unit, measurement scope, linear scale, alarm format etc is changed, setting range and decimal point position changes automatically and relatively hence take care. 		
<p>9. Alarm format of alarm 1 and alarm 2</p> <div style="border: 1px solid black; padding: 5px; margin: 10px 0;"> <p>ALARM AL1:DV -H</p> <p>MODE AL2:DV -H</p> </div>	<ol style="list-style-type: none"> ① Sets alarm format of alarm 1 (AL1) and alarm 2 (AL2). ② There are various alarm formats as follows, set them on the left side of the hyphen (-). Respectively for that, set the higher limit/lower limit, wait no/wait yes, maintenance no/maintenance yes on the right side of the hyphen (-). <table style="width: 100%; border: none;"> <tr> <td style="vertical-align: top; width: 50%;"> <p>[Left side of the hyphen]</p> <ul style="list-style-type: none"> ·PV : Absolute value alarm ·DV : Deviation alarm ·ADV : Absolute value deviation alarm ·SV : Setting value alarm ·MV : Output value alarm </td> <td style="vertical-align: top; width: 50%;"> <p>[Right side of the hyphen]</p> <ul style="list-style-type: none"> ·H : Higher limit alarm ·L : Lower limit alarm ·HW : Wait yes higher limit alarm ·LW : Wait yes lower limit alarm ·HK : Maintenance yes higher limit alarm ·LK : Maintenance yes lower limit alarm ·HWK : Wait yes, maintenance yes higher limit alarm ·LWK : Wait yes, maintenance yes lower limit alarm </td> </tr> </table> <p>Other than these, the following format can also be set according to the specifications.</p> <ul style="list-style-type: none"> ·CT : Heater snapping wire alarm ※ Restricted to specifications with heater snapping wire alarm. ·LOOP : Control loop abnormal alarm ※ Restricted to output 1 specifications. ·TIMER: Timer ※ Restricted to specifications with external signal input. ·FAIL : Fail alarm 	<p>[Left side of the hyphen]</p> <ul style="list-style-type: none"> ·PV : Absolute value alarm ·DV : Deviation alarm ·ADV : Absolute value deviation alarm ·SV : Setting value alarm ·MV : Output value alarm 	<p>[Right side of the hyphen]</p> <ul style="list-style-type: none"> ·H : Higher limit alarm ·L : Lower limit alarm ·HW : Wait yes higher limit alarm ·LW : Wait yes lower limit alarm ·HK : Maintenance yes higher limit alarm ·LK : Maintenance yes lower limit alarm ·HWK : Wait yes, maintenance yes higher limit alarm ·LWK : Wait yes, maintenance yes lower limit alarm
<p>[Left side of the hyphen]</p> <ul style="list-style-type: none"> ·PV : Absolute value alarm ·DV : Deviation alarm ·ADV : Absolute value deviation alarm ·SV : Setting value alarm ·MV : Output value alarm 	<p>[Right side of the hyphen]</p> <ul style="list-style-type: none"> ·H : Higher limit alarm ·L : Lower limit alarm ·HW : Wait yes higher limit alarm ·LW : Wait yes lower limit alarm ·HK : Maintenance yes higher limit alarm ·LK : Maintenance yes lower limit alarm ·HWK : Wait yes, maintenance yes higher limit alarm ·LWK : Wait yes, maintenance yes lower limit alarm 		

<p>10. Alarm format of alarm 3 and alarm 4</p> <div style="border: 1px solid black; padding: 5px; width: fit-content; margin: 10px auto;"> ALARM AL3 : DV -H MODE AL4 : DV -H </div>	<p>① Sets alarm format of alarm 3 (AL3) and alarm 4 (AL4). ② There are various alarm formats as follows, set them on the left side of the hyphen (-). Respectively for that, set the higher limit/lower limit, wait no/wait yes, maintenance no/maintenance yes on the right side of the hyphen (-).</p> <table style="width: 100%; border: none;"> <tr> <td style="vertical-align: top;"> [Left side of the hyphen] ·PV : Absolute value alarm ·DV : Deviation alarm ·ADV: Absolute value deviation alarm ·SV : Setting value alarm ·MV : Output value alarm </td> <td style="vertical-align: top;"> [Right side of the hyphen] ·H : Higher limit alarm ·L : Lower limit alarm ·HW : Wait yes higher limit alarm ·LW : Wait yes lower limit alarm ·HK : Maintenance yes higher limit alarm ·LK : Maintenance yes lower limit alarm ·HWK: Wait yes, maintenance yes higher limit alarm ·LWK : Wait yes, maintenance yes lower limit alarm </td> </tr> </table> <p>Other than these, the following format can also be set according to the specifications.</p> <table style="width: 100%; border: none;"> <tr> <td style="vertical-align: top;"> ·CT : Heater snapping wire alarm ·LOOP : Control loop abnormal alarm ·TIMER : Timer ·FAIL : Fail alarm </td> <td style="vertical-align: top;"> × Restricted to with heater snapping wire alarm. × Restricted to output specifications. × Restricted to specifications with external signal input. </td> </tr> </table>	[Left side of the hyphen] ·PV : Absolute value alarm ·DV : Deviation alarm ·ADV: Absolute value deviation alarm ·SV : Setting value alarm ·MV : Output value alarm	[Right side of the hyphen] ·H : Higher limit alarm ·L : Lower limit alarm ·HW : Wait yes higher limit alarm ·LW : Wait yes lower limit alarm ·HK : Maintenance yes higher limit alarm ·LK : Maintenance yes lower limit alarm ·HWK: Wait yes, maintenance yes higher limit alarm ·LWK : Wait yes, maintenance yes lower limit alarm	·CT : Heater snapping wire alarm ·LOOP : Control loop abnormal alarm ·TIMER : Timer ·FAIL : Fail alarm	× Restricted to with heater snapping wire alarm. × Restricted to output specifications. × Restricted to specifications with external signal input.
[Left side of the hyphen] ·PV : Absolute value alarm ·DV : Deviation alarm ·ADV: Absolute value deviation alarm ·SV : Setting value alarm ·MV : Output value alarm	[Right side of the hyphen] ·H : Higher limit alarm ·L : Lower limit alarm ·HW : Wait yes higher limit alarm ·LW : Wait yes lower limit alarm ·HK : Maintenance yes higher limit alarm ·LK : Maintenance yes lower limit alarm ·HWK: Wait yes, maintenance yes higher limit alarm ·LWK : Wait yes, maintenance yes lower limit alarm				
·CT : Heater snapping wire alarm ·LOOP : Control loop abnormal alarm ·TIMER : Timer ·FAIL : Fail alarm	× Restricted to with heater snapping wire alarm. × Restricted to output specifications. × Restricted to specifications with external signal input.				
<p>11. Alarm dead band</p> <div style="border: 1px solid black; padding: 5px; width: fit-content; margin: 10px auto;"> ALARM D. BAND AL1 002.00 </div>	<p>① Set alarm dead band of alarms 1 to 4. ② Unit is the same as the setting value of respective alarm. ③ When alarm format is TIMER, FAIL, and LOOP, this setting value is disabled. ④ When measurement range, unit, measurement scope, linear scale, alarm format etc is changed, sometimes decimal point position changes automatically and relatively hence take care.</p>				
<p>12. Alarm delay</p> <div style="border: 1px solid black; padding: 5px; width: fit-content; margin: 10px auto;"> ALARM ON DELAY 0000.0s </div>	<p>① Set the delay time of alarm. ② If the judgment time of alarm ON is continuously greater than or equal to the setting value, the alarm turns ON in the beginning. If the judgment time of alarm ON is less than the setting value, alarm does not turn ON. ③ When alarm format is TIMER, FAIL, and LOOP, this setting value becomes disabled. ④ Take care as the setting value is common for alarm of all the 4 points.</p>				
<p>13. Control loop abnormal alarm judgment time</p> <div style="border: 1px solid black; padding: 5px; width: fit-content; margin: 10px auto;"> LOOP ALARM JUDGE 03600s </div>	<p>① This screen is displayed when the instrument has output 1 specification ② Set the judgment time of control loop abnormal alarm. ③ Judge the control loop abnormal alarm by the setting value of alarm and this judgment time.</p>				
<p>14. A.R.W.</p> <div style="border: 1px solid black; padding: 5px; width: fit-content; margin: 10px auto;"> A. R. W. L-050.0% H050.0% </div>	<p>① Set ARW (Anti Reset Windup). ② It is a function for deciding the range of PID operation , for PID control. If this set value is exceeded it becomes a PD operation. ③ Set value is a percentage (%) of measurement scope (including linear scale). ④ Operate when position PID control.</p>				

<p>15. SV 8 types for AT2</p> <div style="border: 1px solid black; padding: 5px; width: fit-content; margin: 10px auto;"> <p style="text-align: center;">AUTO TUNING 2</p> <p style="text-align: center;">SV1 ON 0000.0</p> </div>	<ol style="list-style-type: none"> ① Set 8 types of SV for auto tuning AT2. ② Auto tuning can be set to ON (execute)/OFF (do not execute) for 8 types separately. ③ Setting range is within the measurement scope (including linear scale). ④ PID calculated using SV numbers from 1 to 8 for AT2, correspond to execution numbers 1 to 8 and are registered in PID numbers 1 to 8. ⑤ When measurement range, unit, measurement scope, linear scale etc is changed, sometimes the setting range and decimal point position changes or initialization takes place automatically and relatively hence take care.
<p>16. SV section for automatic PID</p> <div style="border: 1px solid black; padding: 5px; width: fit-content; margin: 10px auto;"> <p style="text-align: center;">SV SCOPE PID No. 9-1</p> <p style="text-align: center;">-0200.0 ~ -0003.8</p> </div>	<ol style="list-style-type: none"> ① Set 8 types of SV sections in automatic PID conversion system. ② Setting range is within the measurement scope (including linear scale). Duplicate SV section cannot be set. ③ When measurement range, unit, measurement scope, linear scale etc is changed, sometimes the setting range and decimal point position changes or initialization takes place automatically and relatively hence take care.
<p>17. SV 8 types for AT3</p> <div style="border: 1px solid black; padding: 5px; width: fit-content; margin: 10px auto;"> <p style="text-align: center;">AUTO TUNING 3</p> <p style="text-align: center;">SV1 OFF -0101.9</p> </div>	<ol style="list-style-type: none"> ① Set 8 types of SV for auto tuning AT3. ② Auto tuning can be set to ON (execute)/OFF (do not execute) for 8 types separately. ③ Setting range is within the range of SV section number of equivalent automatic PID conversion system. ④ PID calculated using SV numbers 1 to 8 for AT3 correspond to automatic PID conversion system numbers from 9-1 to 9-8 and are registered. ⑤ When measurement range, unit, measurement scope, linear scale etc is changed, sometimes the setting range and decimal point position changes or initialization takes place automatically and relatively hence take care.
<p>18. AT2, AT3 Start direction</p> <div style="border: 1px solid black; padding: 5px; width: fit-content; margin: 10px auto;"> <p style="text-align: center;">AT2/AT3 START</p> <p style="text-align: center;">UP DOWN</p> </div>	<ol style="list-style-type: none"> ① Set execution direction at the time of executing auto tuning AT2 or AT3. ② If 'UP' is selected, auto tuning progresses from SV1 to SV8. ③ If 'DOWN' is selected, auto tuning progresses from SV8 to SV1.
<p>19. Control algorithm</p> <div style="border: 1px solid black; padding: 5px; width: fit-content; margin: 10px auto;"> <p style="text-align: center;">PID TYPE</p> <p style="text-align: center;">POSITION/VELOCITY</p> </div>	<ol style="list-style-type: none"> ① Set control algorithm. ② If 'POSITION' is selected, it is position type PID system. ③ If 'VELOCITY' is selected, it is speed type PID system.

7-6. Mode 4

Mode 4 performs the setting related to output.

Settings screen	Description of the screen
<p>1. Mode screen</p> <div style="border: 1px solid black; padding: 5px; margin-bottom: 10px;"> MODE 4 OUTPUT SET </div> <p>[Lock Status]</p> <div style="border: 1px solid black; padding: 5px; margin-bottom: 10px;"> MODE 4 Lock OUTPUT SET </div> <p>[Display OFF status]</p> <div style="border: 1px solid black; padding: 5px;"> MODE 4 NoDisp OUTPUT SET </div>	<ul style="list-style-type: none"> ① Mode 4 screen. ② By clicking the  key, 'Lock' and 'NoDisp' is displayed. ③ For mode 4 settings screen, if setting change is to be prohibited select 'Lock'. ④ When doing the settings by communications, set all the mode screens to 'Lock'. ⑤ When settings screen of mode 4 is not displayed, select 'NoDisp'.
<p>2. Pulse cycle</p> <div style="border: 1px solid black; padding: 5px; margin-bottom: 10px;"> PULSE CYCLE 0 3 0 s </div> <p>[Output 2 specifications]</p> <div style="border: 1px solid black; padding: 5px;"> PULSE CYCLE OUT1/2 0 3 0 s / 0 3 0 s </div>	<ul style="list-style-type: none"> ① Output format of only ON-OFF pulse type or SSR drive pulse type is displayed. ② Set time for one cycle of output ON/OFF. ③ In output 2 specifications, for pulse type also set output 2 respectively. ④ When set value is changed, after ending one cycle just before the setting change value, perform the operation with the settings value after the setting change. ⑤ Generally, set it in a range that does not adversely affect the controllability and set a bigger value as far as possible.
<p>3. FB tuning</p> <div style="border: 1px solid black; padding: 5px; margin-bottom: 10px;"> F. B. AUTO TUNING END START </div>	<ul style="list-style-type: none"> ① ON-OFF servo type only is displayed. ② It is a function that automatically requests a setting value of FB zero span of the controller with actuator (motor etc.). ③ When FB tuning is started, AT progress status (START, CLOSE, TUNE-ZERO, OPEN, TUNE-SPAN) is displayed. ④ If FB tuning is to be stopped in between, set 'END'. ⑤ FB zero span requested at the time of FB tuning can be confirmed by 'FB zero span' of mode 4.
<p>4. FB zero span</p> <div style="border: 1px solid black; padding: 5px;"> F. B. ZERO / SPAN Z : 0 0 . 0 % S : 1 0 0 . 0 % </div>	<ul style="list-style-type: none"> ① ON-OFF servo type only is displayed. ② Set FB zero span of the controller with actuator (motor etc). ③ Set zero value in 'Z' and span value in 'S'.

<p>5. FB dead band</p> <div style="border: 1px solid black; padding: 5px; width: fit-content; margin: 10px auto;"> <p>F . B . D . B A N D</p> <p style="text-align: center;">1 . 0 %</p> </div>	<ol style="list-style-type: none"> ① ON-OFF servo type only is displayed. ② Set FB dead band (Gain). ③ Generally, set it in a range that does not adversely affect the controllability and set a bigger value as far as possible. This setting value is not an accurate percentage (%) value, hence as far as possible take it as a reference.
<p>6. Output during PV abnormality</p> <div style="border: 1px solid black; padding: 5px; width: fit-content; margin: 10px auto;"> <p>P V E R R O V R : 0 0 0 . 0 %</p> <p style="text-align: center;">O U T U D R : 0 0 0 . 0 %</p> </div>	<ol style="list-style-type: none"> ① Set the output value at the time of PV abnormality. ② Set the output value in 'OVR' when PV exceeds the range (including higher limit burnout) and in 'UDR' when PV is below the range (including lower limit burnout) respectively. ③ Output range is within the output limiter range. ④ In case of output 2 specifications, this value is enabled only on output 1 side and on output 2 side the output value is 0% at all times.
<p>7. Output preset 8 types</p> <div style="border: 1px solid black; padding: 5px; width: fit-content; margin: 10px auto;"> <p style="text-align: center;">O U T P U T P R E S E T</p> <p style="text-align: center;">No. 1 0 5 0 . 0 %</p> </div>	<ol style="list-style-type: none"> ① Set 8 types of output presets. ② Numbers 1 to 8 correspond to execution numbers 1 to 8. ③ Output range is within output limiter range. ④ In case of output 2 specification, this setting value is valid only output 1 side and output 2 side is 0% fixed.
<p>8. Output variation limiter 8 types</p> <div style="border: 1px solid black; padding: 5px; width: fit-content; margin: 10px auto;"> <p>O S L U P / D O W N No. 1</p> <p style="text-align: center;">1 0 0 . 0 % / - 1 0 0 . 0 %</p> </div>	<ol style="list-style-type: none"> ① Set 8 types of output variation limiters. ② Numbers 1 to 8 correspond to execution numbers 1 to 8. ③ On the lower left set output variation limiter at the time of ascending output and on the lower right set output variation limiter at the time of descending output. ④ In case of preset manual, displayed until No. 9 and variation limiter of MV (output value) which is switched from auto output operation to output preset operation at No. 9 is set.
<p>9. Output limiter 8 types</p> <div style="border: 1px solid black; padding: 5px; width: fit-content; margin: 10px auto;"> <p style="text-align: center;">O U T P U T L I M I T No. 1</p> <p style="text-align: center;">L : 0 0 0 . 0 % H : 1 0 0 . 0 %</p> </div> <p>[Output scale specifications]</p> <div style="border: 1px solid black; padding: 5px; width: fit-content; margin: 10px auto;"> <p style="text-align: center;">O U T P U T S C A L E No. 1</p> <p style="text-align: center;">L : 0 0 0 . 0 % H : 1 0 0 . 0 %</p> </div> <p style="text-align: center;">※ Option</p>	<ol style="list-style-type: none"> ① Set 8 types of output limiters. ② Numbers 1 to 8 correspond to execution numbers 1 to 8. ③ Set lower limit output limiter in 'L' and higher limit output limiter in 'H'. ④ Output is within this set range in case of automatic output operation and manual output operation also. ⑤ Instead of output limiter, the screen is as shown on the left below for output scale specifications (option).

<p>10. Output 2 limiter</p> <pre> OUT2 OUTPUT LIMIT L:000.0% H:100.0% </pre> <p>[Output scale specifications]</p> <pre> OUT2 OUTPUT SCALE L:000.0% H:100.0% </pre> <p>※ Option</p>	<ol style="list-style-type: none"> ① Only output 2 specifications are displayed. ② Set the output limiter of output 2 side. ③ Set lower limit output limiter in 'L' and higher limit output limiter in 'H'. ④ Output is within this set range in for automatic output operation and manual output operation also. ⑤ Instead of output limiter, the screen is as shown on the left below for output scale specifications (option).
<p>11. Direct/reverse control action</p> <pre> OUTPUT MODE DIRECT REVERSE </pre> <p>[Output 2 specifications]</p> <pre> OUTPUT MODE OUT1/2 REVERSE / DIRECT </pre>	<ol style="list-style-type: none"> ① Set the control action. ② If 'DIRECT' is selected direct operation (cooling operation) is done. ③ If 'REVERSE' is selected reverse operation (heating operation) is done. ④ For output 2 specifications, see the screen on lower left, on the left of '/' is the control action of output 1 and on the right is the control action of output 2. Set each of them separately.
<p>12. Preset manual</p> <pre> PRESET MANUAL OUT 000.0% </pre> <p>[Output 2 specifications]</p> <pre> PRESET MANU OUT1/2 000.0% / 000.0% </pre>	<ol style="list-style-type: none"> ① Set the preset manual. ② For ready status or for specifications with external signal input, when preset manual has ON status due to external signal input, the output value is this set value. ③ Output range is within the range of output limiter. ④ For output 2 specifications the screen is as shown on the left below, set each of the field separately..
<p>13. Output 2 control system</p> <pre> OUT2 CONTROL TYPE PID SPRIT </pre>	<ol style="list-style-type: none"> ① Only output 2 specifications are displayed. ② Set the control system of output 2 specifications. ③ If 'PID' is selected the operation is PID control action. ④ If 'SPRIT' is selected the operation is SPRIT control action.
<p>14. SPRIT</p> <pre> SPRIT DIR: 00.0% REV:100.0% </pre>	<ol style="list-style-type: none"> ① In case of output 2 specifications, output 2 control specifications are displayed only when 'SPRIT' is selected. ② Set direct value in 'DIR' and reverse value in 'REV'.

7-7. Mode 5

Mode 5 performs the setting related to input.

Settings screen	Description of the screen
<p>1. Mode screen</p> <div style="border: 1px solid black; padding: 5px; text-align: center;"> MODE 5 INPUT SET </div> <p>[Lock Status]</p> <div style="border: 1px solid black; padding: 5px; text-align: center;"> MODE 5 Lock INPUT SET </div> <p>[Display OFF status]</p> <div style="border: 1px solid black; padding: 5px; text-align: center;"> MODE 5 NoDisp INPUT SET </div>	<p>① Mode 5 screen.</p> <p>② By clicking the  key, 'Lock' and 'NoDisp' is displayed.</p> <p>③ For mode 5 settings screen, if setting change is to be prohibited select 'Lock'.</p> <p>④ When doing the settings by communications, set all the mode screens to 'Lock'.</p> <p>⑤ When settings screen of mode 5 is not displayed, select 'NoDisp'.</p>
<p>2. Measurement range</p> <div style="border: 1px solid black; padding: 5px; text-align: center;"> INPUT KIND 0 5 K 1 </div>	<p>① Set the measurement range.</p> <p>② Types of measurement ranges are as shown in the table below.</p> <p>③ It differs depending on the measurement range, however it exceeds the higher limit value of the scale range by approximately +5% and is below the range by approximately -5%.</p> <p>④ When measurement range is changed, sometimes the setting range and decimal point position changes or initialization takes place automatically and relatively hence take care.</p>

[Universal]

No.	Measurement range	Scale range (°C)	No.	Measurement range	Scale range (°C)	No.	Measurement range	Scale range (°C)			
01	Thermocouple	B	0.0 to 1820.0	18	Thermocouple	WRe5-26	0.0 to 2310.0	36	Direct current (Linear)	20mA	0 to 20mA
02		R1	0.0 to 1760.0	19		W-WRe26	0.0 to 2310.0				
03		R2	0.0 to 1200.0	20		NiMo-Ni	-50.0 to 1410.0				
04		S	0.0 to 1760.0	21		CR-AuFe	0.0 to 280.0K	41	Resistance thermometer	JPt100Q1	-200.0 to 649.0
05		K1	-200.0 to 1370.0	22		N	0.0 to 1300.0	42		JPt100Q2	-200.0 to 400.0
06		K2	0.0 to 600.0	23		PR5-20	0.0 to 1800.0	44		JPt100Q4	-200.0 to 200.0
07		K3	-200.0 to 300.0	24		PtRh40-20	0.0 to 1880.0	45		JPt100Q5	-100.0 to 100.0
08		E1	-270.0 to 1000.0	25		Plati II 1	0.0 to 1390.0	46		QPt100Q1	-200.0 to 649.0
09		E2	0.0 to 700.0	26		Plati II 2	0.0 to 600.0	47		QPt100Q2	-200.0 to 400.0
10		E3	-270.0 to 300.0	27		U	-200.0 to 400.0	49		QPt100Q4	-200.0 to 200.0
11		E4	-270.0 to 150.0	28	L	-200.0 to 900.0	50	QPt100Q5	-100.0 to 100.0		
12		J1	-200.0 to 1200.0	31	DC voltage (Linear)	10mV	±10mV	51	JPt50Q	-200.0 to 649.0	
13		J2	-200.0 to 900.0	32		20mV	±20mV	53	Pt100Q1	-200.0 to 850.0	
14		J3	-200.0 to 400.0	33		50mV	±50mV	54	Pt100Q2	-200.0 to 400.0	
15		J4	-100.0 to 200.0	34		100mV	±100mV	56	Pt100Q4	-200.0 to 200.0	
16		T1	-270.0 to 400.0	35		5V	±5V	57	Pt100Q5	-100.0 to 100.0	
17		T2	-200.0 to 200.0	37		10V	±10V				

[4-wire type resistance thermometer]

No.	Measurement range	Scale range (°C)	No.	Measurement range	Scale range (°C)	No.	Measurement range	Scale range (°C)
41	JPt100Ω1	-200.0 to 649.0	47	QPt100Ω2	-200.0 to 400.0	53	Pt100Ω1	-200.0 to 850.0
42	JPt100Ω2	-200.0 to 400.0	49	QPt100Ω4	-200.0 to 200.0	54	Pt100Ω2	-200.0 to 400.0
44	JPt100Ω4	-200.0 to 200.0	50	QPt100Ω5	-100.0 to 100.0	56	Pt100Ω4	-200.0 to 200.0
45	JPt100Ω5	-100.0 to 100.0	51	JPt50Ω	-200.0 to 649.0	57	Pt100Ω5	-100.0 to 100.0
46	QPt100Ω1	-200.0 to 649.0	52	Pt-Co	4.0 to 374.0 K			

3. Unit

MEASURE UNIT
° C K

- ① Set the unit when measurement range is “thermocouple” or “resistance thermometer”.
- ② When measurement range is 'CR-AuFe' or 'Pt-Co' only then the unit is 'K' and '°C' is not selected.
- ③ When unit is changed, sometimes the setting range and decimal point position changes or initialization takes place automatically and relatively hence take care.

4. RJ

RJ CALCULATION
INT EXT

- ① This screen is displayed when select “thermocouple”.
- ② When 'INT' is selected RJ functionality is switched ON. Usually 'INT' is selected.
- ③ When 'EXT' is selected RJ functionality is switched OFF.

5. Digital filter

PV FILTER
0 0 . 1 s

- ① Do the first-order lag operation in PV. This function is enabled when PV is unstable.

6. Sensor correction

INPUT SHIFT
No. 1 0 0 0 . 0 0

- ① Set 8 types of sensor corrections (PV bias).
- ② Numbers 1 to 8 correspond to execution numbers 1 to 8.
- ③ When measurement range, unit, measurement scope, linear scale etc is changed, sometimes the decimal point position changes automatically and relatively hence take care.

7. PV decimal point

PV DISPLAY DOT
1

- ① Set the decimal point position of PV.
- ② Based on the decimal point position that is set, up to five digits including the integer part are displayed. Hence only if the number of digits of integer is less, then more number of digits after the decimal point can be displayed within the range of decimal point position that is set.
- ③ When measurement range, unit, measurement scope, linear scale etc is changed, sometimes the decimal point position changes automatically and relatively hence take care.

<p>8. Measurement scope</p> <div style="border: 1px solid black; padding: 5px; text-align: center;"> RANGE SET - 0 2 0 0 . 0 ~ 1 3 7 0 . 0 </div> <p>[Linear input]</p> <div style="border: 1px solid black; padding: 5px; text-align: center;"> RANGE SET 0 0 0 . 0 0 ~ 0 1 0 . 0 0 </div>	<ol style="list-style-type: none"> ① The measurement scope that is actually used is set in scale of measurement range. ② For thermocouple and resistance thermometer, the meaning of measurement scope is as follows. <ul style="list-style-type: none"> ▪ P of PID operation = Equivalent to 100%. ▪ Maximum set range like SV range. ③ For linear input, the meaning of measurement scope is as follows. <ul style="list-style-type: none"> ▪ Standard range which is the basis of linear scale (with scale). ④ Setting range is within the scale range of the selected measurement range. ⑤ When measurement scope is changed, sometimes the setting range and decimal point position changes or initialization takes place automatically and relatively hence take care.
<p>9. Linear scale</p> <div style="border: 1px solid black; padding: 5px; text-align: center;"> LINEAR SCALE DOT 1 0 0 0 0 . 0 ~ 2 0 0 0 . 0 </div>	<ol style="list-style-type: none"> ① Measurement range is displayed only when 'linear input' is selected. ② Set a scale (with scale) for the standard range that is set in measurement range. P of PID operation = Equivalent to 100%. ③ Set the decimal point position in 'DOT', lower limit value (0%) of the scale on the lower left and upper limit value (100%) on the lower right. ④ When linear scale is changed, sometimes the setting range and decimal point position changes or initialization takes place automatically and relatively hence take care.
<p>10. SV decimal point for displaying</p> <div style="border: 1px solid black; padding: 5px; text-align: center;"> SV DISPLAY DOT 1 </div>	<ol style="list-style-type: none"> ① Set the decimal point position of SV which is displayed at the upper display. ② Based on the decimal point position that is set, up to five digits including the integer part are displayed. Hence only if the number of digits of integer is less, more number of digits after the decimal point can be displayed within the range of decimal point position that is set. ③ When measurement range, unit, linear scale etc is changed, setting range and decimal point position may change automatically hence take care.

7-8. Mode 6

Mode 6 performs the settings of transmission signal output.







Settings screen	Description of the screen
<p>1. Mode screen</p> <div style="border: 1px solid black; padding: 5px; text-align: center;"> MODE <u>6</u> TRANSMITTER </div> <p>[Lock Status]</p> <div style="border: 1px solid black; padding: 5px; text-align: center;"> MODE <u>6</u> Lock TRANSMITTER </div> <p>[Display OFF status]</p> <div style="border: 1px solid black; padding: 5px; text-align: center;"> MODE <u>6</u> NoDisp TRANSMITTER </div>	<ol style="list-style-type: none"> ① Mode 6 screen. Only specifications with transmission signal output are displayed. ② By clicking the <input type="checkbox"/> key, 'Lock' and 'NoDisp' is displayed. ③ For mode 6 settings screen, if setting change is to be prohibited select 'Lock'. ④ When doing the settings by communication, set all the mode screens to 'Lock'. ⑤ When settings screen of mode 6 is not displayed, select 'NoDisp'.

<p>2. Transmission type (High-performance type)</p> <div style="border: 1px solid black; padding: 5px; width: fit-content; margin: 10px auto;"> <p>TRANS(HIGH) KIND PV SV MV MFB RSV</p> </div>	<ol style="list-style-type: none"> ① Specifications with transmission signal output (High performance type) only are displayed. ② Set transmission type of high performance type. ③ When 'PV' is selected, measurement value (PV) is transmitted. ④ When 'SV' is selected, setting value (SV) is transmitted. ⑤ When 'MV' is selected, output value (MV) is transmitted. ⑥ When 'MFB' is selected, actuator feedback value (MFB) is transmitted, but ON-OFF servo type only. ⑦ When 'RSV' is selected, remote SV (RSV) is transmitted. However it can be selected only in case of specifications with remote signal input. ⑧ Even if operating local SV, remote SV (RSV) is transmitted. ⑨ In case of output 2 specifications, you can select separately 'MV1' on output 1 side and 'MV2' on output 2 side. ⑩ When transmission type is changed sometimes setting range and decimal point position changes or it is initialized automatically and relatively hence take care.
<p>3. Transmission scale (High-performance type)</p> <div style="border: 1px solid black; padding: 5px; width: fit-content; margin: 10px auto;"> <p>TRANS(HIGH) SCALE L-0200.0 ~H1370.0</p> </div>	<ol style="list-style-type: none"> ① Only specifications with transmission signal output (High performance type) are displayed. ② Set a scale corresponding to transmission signal output (Analog signal) of high performance type. ③ Set lower limit (0%) and higher limit (100%) of the scale for the minimum value (0%) and maximum value (100%) of the transmission signal output. ④ When transmission scale is changed, sometimes setting range and decimal point position changes automatically and relatively hence take care.
<p>4. Transmission type (General type)</p> <div style="border: 1px solid black; padding: 5px; width: fit-content; margin: 10px auto;"> <p>TRANS(NORMAL) KIND PV SV MV MFB RSV</p> </div>	<ol style="list-style-type: none"> ① Only the specifications with transmission signal output (General type) are displayed. ② Set transmission type of general type. ③ When 'PV' is selected, measurement value (PV) is transmitted. ④ When 'SV' is selected, setting value (SV) is transmitted. ⑤ When 'MV' is selected, output value (MV) is transmitted. ⑥ When 'MFB' is selected, actuator feedback value (MFB) is transmitted. But the output format can be selected only in case of ON-OFF servo type. ⑦ When 'RSV' is selected, remote SV (RSV) is transmitted. However it can be selected only in case of specifications with remote signal input. ⑧ Even if operating local SV, remote SV (RSV) is transmitted. ⑨ In case of output 2 specifications, you can select separately 'MV1' on output 1 side and 'MV2' on output 2 side. ⑩ When transmission type is changed sometimes setting range and decimal point position changes or it is initialized automatically and relatively hence take care.
<p>5. Transmission scale (General type)</p> <div style="border: 1px solid black; padding: 5px; width: fit-content; margin: 10px auto;"> <p>TRANS(NORMAL) SCALE L-0200.0 ~H1370.0</p> </div>	<ol style="list-style-type: none"> ① Only the specifications with transmission signal output (General type) are displayed. ② Set the scale corresponding to transmission signal output (Analog signal) of general type. ③ Set lower limit (0%) and upper limit (100%) of the scale for the minimum value (0%) and maximum value (100%) of the transmission signal output. ④ When transmission scale is changed, sometimes setting range and decimal point position changes automatically and relatively hence take care.

7-9. Mode 7

Mode 7 performs the setting related to communications.

For details related to communications read its exclusive instruction manual.

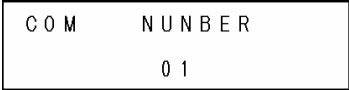
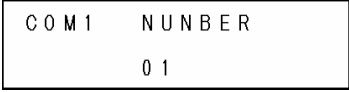
Settings screen	Description of the screen
<p>1. Mode screen</p>  <p>[Lock Status]</p>  <p>[Display OFF status]</p> 	<ul style="list-style-type: none"> ① Mode 7 screen. Only the instrument with communications is displayed. ② By clicking the  key, 'Lock' and 'NoDisp' is displayed. ③ For mode 7 settings screen, if setting change is to be prohibited select 'Lock'. ④ When doing the settings by communications, set all the mode screens to 'Lock'. ⑤ When settings screen of mode 7 is not displayed, select 'NoDisp'.
<p>2. Communications speed</p>  <p>[Communications 2 port specifications]</p> 	<ul style="list-style-type: none"> ① Only the instrument with communications is displayed. ② Set the communication speed. ③ In case of communications 2 port specification, this setting screen becomes the communications speed for COM1.
<p>3. Instrument number</p>  <p>[Communications 2 port specifications]</p> 	<ul style="list-style-type: none"> ① Only the instrument with communications is displayed. ② Set the instrument number. ③ In case of communications 2 port specifications, this setting screen becomes the instrument number for COM1.

<p>4. Communications function</p> <div style="border: 1px solid black; padding: 5px; margin: 10px 0;"> COM KIND COM REM TRANS </div> <p>[Communications 2 port specifications]</p> <div style="border: 1px solid black; padding: 5px; margin: 10px 0;"> COM1 KIND COM REM TRANS </div>	<ol style="list-style-type: none"> ① Only the instrument with communications is displayed. ② Set the communications function. ③ If 'COM' is selected it is higher order communications function. ④ If 'REM' is selected, it is communications remote function. ⑤ If 'TRANS' is selected, it is communications transmission function. ⑥ In case of communications 2 port specifications, this setting screen becomes the communications function for COM1.
<p>5. Communications transmission types</p> <div style="border: 1px solid black; padding: 5px; margin: 10px 0;"> COM TRANS KIND PV SV MV MFB RSV </div> <p>[Communications 2 port specifications]</p> <div style="border: 1px solid black; padding: 5px; margin: 10px 0;"> COM1 TRANS KIND PV SV MV MFB RSV </div>	<ol style="list-style-type: none"> ① It only displays with the instrument with communications, and when 'TRANS' is selected. ② Set the communications transmission type. ③ When 'PV' is selected, measurement value (PV) is transmitted. ④ When 'SV' is selected, setting value (SV) is transmitted. ⑤ When 'MV' is selected, output value (MV) is transmitted. ⑥ When 'MFB' is selected, actuator feedback value (MFB) is transmitted, but ON-OFF servo type only. ⑦ When 'RSV' is selected, remote SV (RSV) is transmitted. However it can be selected only in case of specifications with remote signal input. ⑧ In case of output 2 specifications, you can select separately output 1 side 'MV1' and output 2 side 'MV2'. ⑨ In case of communications 2 port specifications, this setting screen becomes the communications transmission type for COM1.
<p>6. Communications protocol</p> <div style="border: 1px solid black; padding: 5px; margin: 10px 0;"> COM PROTOCOL MODBUS(RTU) </div> <p>[Communications 2 port specifications]</p> <div style="border: 1px solid black; padding: 5px; margin: 10px 0;"> COM1 PROTOCOL MODBUS(RTU) </div>	<ol style="list-style-type: none"> ① Only the instrument with communications is displayed. ② Set communications protocol. ③ If 'MODBUS (RTU)' is selected, MODBUS (RTU) is displayed. ④ If 'MODBUS (ASCII)' is selected, MODBUS (ASCII) is displayed. ⑤ If 'PRIVATE' is selected, usual CHINO protocol is displayed. ⑥ In case of communications 2 port specifications, this setting screen becomes the communications protocol for COM1.
<p>7. Communications character</p> <div style="border: 1px solid black; padding: 5px; margin: 10px 0;"> COM CHARACTER 8 BIT / NON / STOP 1 </div> <p>[Communications 2 port specifications]</p> <div style="border: 1px solid black; padding: 5px; margin: 10px 0;"> COM1 CHARACTER 8 BIT / NON / STOP 1 </div>	<ol style="list-style-type: none"> ① It only displays with the instrument with communications, and when 'MODBUS' is selected. ② Set communications character (bit length, parity, stop bit). ③ In case of communications 2 port specifications, this setting screen becomes the communications character for COM1.

<p>8. Selecting communications 2 port function</p> <div style="border: 1px solid black; padding: 5px; width: fit-content; margin: 10px auto;"> <p>COM2 PORT SELECT COM ENG</p> </div>	<ol style="list-style-type: none"> ① Only the instrument whit communications 2 port specifications is displayed. ② Set the function of communications 2 port. ③ If 'COM' is selected, 2 port communications is possible from the rear terminal. ④ If 'ENG' is selected, 1 port communications is possible from the rear terminal and engineering port communications that exists in the front is possible.
<p>9. Communications speed for COM2</p> <div style="border: 1px solid black; padding: 5px; width: fit-content; margin: 10px auto;"> <p>COM2 BIT RATE 9600 bps</p> </div>	<ol style="list-style-type: none"> ① In communications 2 port specifications, communications 2 port function selection is displayed only at the time of selecting 'COM'. ② Set the communications speed for COM2.
<p>10. Instrument number for COM2</p> <div style="border: 1px solid black; padding: 5px; width: fit-content; margin: 10px auto;"> <p>COM2 NUMBER 01</p> </div>	<ol style="list-style-type: none"> ① In communications 2 port specifications, communications 2 port function selection is displayed only at the time of selecting 'COM'. ② Set the instrument number for COM2.
<p>11. Communications function for COM2</p> <div style="border: 1px solid black; padding: 5px; width: fit-content; margin: 10px auto;"> <p>COM2 KIND COM REM TRANS</p> </div>	<ol style="list-style-type: none"> ① In communications 2 port specifications, communications 2 port function selection is displayed only at the time of selecting 'COM1 COM2'. ② Set the communications function for COM2. ③ If 'COM' is selected it becomes high order communications function. ④ If 'REM' is selected it becomes communications remote function. ⑤ If 'TRANS' is selected it becomes communications transmission function.
<p>12. Communications transmission types for COM2</p> <div style="border: 1px solid black; padding: 5px; width: fit-content; margin: 10px auto;"> <p>COM2 TRANS KIND PV SV MV MFB RSV</p> </div>	<ol style="list-style-type: none"> ① In communications 2 port specifications, communications function for COM2 is displayed only when 'TRANS' is selected. ② Set communications transmission type for COM2. ③ When 'PV' is selected, measurement value (PV) is transmitted. ④ When 'SV' is selected, setting value (SV) is transmitted. ⑤ When 'MV' is selected, output value (MV) is transmitted. ⑥ When 'MFB' is selected, actuator feedback value (MFB) is transmitted, but ON-OFF servo type only. ⑦ When 'RSV' is selected, remote SV (RSV) is transmitted. However it can be selected only in case of specifications with remote signal input. ⑧ In case of output 2 specifications, you can select separately output 1 side 'MV1' and output 2 side 'MV2'.
<p>13. Communications protocol for COM2</p> <div style="border: 1px solid black; padding: 5px; width: fit-content; margin: 10px auto;"> <p>COM2 PROTOCOL MODBUS (RTU)</p> </div>	<ol style="list-style-type: none"> ① In communications 2 port specifications, communications 2 port function selection is displayed only at the time of selecting 'COM'. ② Set the communications protocol for COM2. ③ If 'MODBUS (RTU)' is selected, MODBUS (RTU) is displayed. ④ If 'MODBUS (ASCII)' is selected, MODBUS (ASCII) is displayed. ⑤ If 'PRIVATE' is selected, usual CHINO protocol is displayed.

<p>14. Communications character for COM2</p> <div style="border: 1px solid black; padding: 5px; width: fit-content; margin: 10px auto;"> <p>COM2 CHARACTER 8BIT/NON /STOP1</p> </div>	<p>① In communications 2 port specifications, communications protocol for COM2 is displayed only when 'MODBUS' is selected.</p> <p>② Set communications character (bit length/parity/stop bit) for COM2.</p>
---	--

7-10. Mode 11

Mode 11 performs the setting related to system (Initial settings of the system).

Settings screen	Description of the screen
<p>1. Mode screen</p> <div style="border: 1px solid black; padding: 5px; margin: 10px 0;"> <p>MODE 11 SYSTEM 1</p> </div> <p>[Lock Status]</p> <div style="border: 1px solid black; padding: 5px; margin: 10px 0;"> <p>MODE 11 Lock SYSTEM 1</p> </div> <p>[Display OFF status]</p> <div style="border: 1px solid black; padding: 5px; margin: 10px 0;"> <p>MODE 11 NoDisp SYSTEM 1</p> </div>	<p>① Mode 11 screen.</p> <p>② By clicking the  key, 'Lock' and 'NoDisp' is displayed.</p> <p>③ For mode 11 settings screen, if setting change is to be prohibited select 'Lock'.</p> <p>④ When doing the settings by communications, set all the mode screens to 'Lock'.</p> <p>⑤ When settings screen of mode 11 is not displayed, select 'NoDisp'.</p>
<p>2. Display back light</p> <div style="border: 1px solid black; padding: 5px; margin: 10px 0;"> <p>DISPLAY BACK LIGHT GREEN ORANGE AUTO</p> </div>	<p>① Set the back light color of lower display.</p> <p>② If 'GREEN' is selected, usually green color is displayed.</p> <p>③ If 'ORANGE' is selected, usually orange color is displayed.</p> <p>④ If 'AUTO' is selected, usually green color is displayed however under the following conditions, orange color is displayed.</p> <ul style="list-style-type: none"> ▪ When any of the alarms is activated. ▪ When an error message is displayed. <p>By effective use of this function, alarm on/off can be judged at a glance.</p>
<p>3. Display contrast</p> <div style="border: 1px solid black; padding: 5px; margin: 10px 0;"> <p>DISPLAY VIEW ANGLE 050%</p> </div>	<p>① It adjusts the contrast of LCD (Liquid crystal display) of lower display window.</p> <p>② Adjust and set the LCD such that the characters are clearly visible. 40 to 70% of range is suitable for setting value. When set the range over or under, stripes appear in the LCD. Do not change the setting (initial value 50%) in ordinary use.</p> <p>③ Contrast especially affects the surrounding temperature hence do this adjustment approximately one hour after switching on the power supply and after the surrounding temperature becomes stable.</p>

<p>4. Key back light</p> <div style="border: 1px solid black; padding: 5px; text-align: center;"> KEY BACK LIGHT AUTO OFF ON </div>	<p>① It sets the illumination/non-illumination function of key backlight. ② If 'AUTO' is selected, the following operation takes place. · Usually it is non-illuminated, however when power is supplied or if any of the key is pressed, it illuminates and get switched off if no key operation is done for approximately 30 seconds. ③ If 'OFF' is selected, it usually gets switched OFF. ④ If 'ON' is selected, it usually illuminates.</p>
<p>5. Allotting external signal</p> <div style="border: 1px solid black; padding: 5px; text-align: center;"> TERMINAL No. 1 2 DI RUN/STOP </div>	<p>① Only the specifications with external signal input are displayed. ② In external signal input (DI), a function for terminal number is allotted. ③ In 'TERMINAL No.' terminal number having external signal input (DI) function is displayed hence set the terminal number (No.) and the function corresponding to it. ④ Function is as follows: · 'SV1' : Selecting execution number. When it is ON, BCD code is '1'. · 'SV2' : Selecting execution number. When it is ON, BCD code is '2'. · 'SV4' : Selecting execution number. When it is ON, BCD code is '4'. · 'SV8' : Selecting execution number. When it is ON, BCD code is '8'. · 'READY/RUN' : READY status when ON, RUN status when OFF. · 'MAN1/AUTO1' : Manual output operation on (MANUAL) output 1 side, when ON. Automatic output operation (AUTO) on output 1 side, when OFF. · 'MAN2/AUTO2' : Manual output operation (MANUAL) on output 2 side, when ON. Automatic output operation (AUTO) on output 2 side, when OFF. × However only output 2 specifications can be selected. · 'PRESET/AUTO' : Preset manual (PRESET) when ON. Automatic output operation (AUTO) when OFF. · 'ALARM RESET' : Cancel alarm (ALARM RESET) output when ON (momentary signal). · 'PV HOLD' : PV HOLD when ON. · 'TIMER 1' : Timer 1 start when ON. Timer 1 reset when OFF. · 'TIMER 2' : Timer 2 start when ON. Timer 2 reset when OFF. · 'TIMER 3' : Timer 3 start when ON. Timer 3 reset when OFF. · 'TIMER 4' : Timer 4 start when ON. Timer 4 reset when OFF. · 'SLOPE HOLD' : SV slope function is in hold (SLOPE HOLD) status when ON. · 'SLOPE RESET' : SV slope function is cancelled when ON (momentary signal). ⑤ No setting condition '-----' is displayed when shipped from factory. If set any function once, not setting condition is not displayed. ⑥ Allotted setting is not initialized even if setting content is initialized.</p>
<p>6. Alarm output check</p> <div style="border: 1px solid black; padding: 5px; text-align: center;"> ALARM OUT CHECK OFF AL1 2 3 4 </div>	<p>① It is a check function of alarm output. ② When this setting screen is displayed, the current alarm activation status of alarm of 4 points is OFF. When select the alarm which would like to ON and click  key, it become ON until selecting OFF. Using this function effectively facilitates the system checking of the final product. ③ When this screen is removed, alarm output automatically returns to current alarm activation status.</p>

 Precaution	All outputs are turned OFF. When it is troubled by becoming OFF, click the mode key, and remove from the alarm output check screen.
---	---

7-11. Mode 12

Mode 12 performs the setting related to system (customer scale correction).

Normally it is not necessary to set this mode. This mode is necessary only when scale correction is to be done during periodic review for the customer.

Settings screen	Description of the screen
<p>1. Mode screen</p> <div style="border: 1px solid black; padding: 5px; margin: 5px 0;"> <p>MODE 12 SYSTEM 2</p> </div> <p>[Lock Status]</p> <div style="border: 1px solid black; padding: 5px; margin: 5px 0;"> <p>MODE 12 Lock SYSTEM 2</p> </div> <p>[Display OFF status]</p> <div style="border: 1px solid black; padding: 5px; margin: 5px 0;"> <p>MODE 12 NoDisp SYSTEM 2</p> </div>	<p>① Mode 12 screen.</p> <p>② By clicking the \boxtimes key, 'Lock' and 'NoDisp' is displayed.</p> <p>③ For mode 12 settings screen, if setting change is to be prohibited select 'Lock'.</p> <p>④ When doing the settings by communications, set all the mode screens to 'Lock'.</p> <p>⑤ When settings screen of mode 12 is not displayed, select 'NoDisp'.</p>
<p>2. Measurement range, zero correction</p> <div style="border: 1px solid black; padding: 5px; margin: 5px 0;"> <p>USER CAL INPUT ZERO = 00.000</p> </div>	<p>① It is a function that performs zero correction (Bias operation) of measurement range.</p> <p>② '0.0' being the standard, if minus value is set, it indicates low measurement value. If plus value is set, it indicates high measurement value.</p>
<p>3. Measurement range span correction</p> <div style="border: 1px solid black; padding: 5px; margin: 5px 0;"> <p>USER CAL INPUT SPAN = 1.0000</p> </div>	<p>① It is a function that does the span correction (coefficient calculation) of measurement range.</p> <p>② '1.0' being the standard, if a small value is set tilting becomes smaller indicating lower measurement value. On the other hand if a large value is set, the tilting is bigger indicating higher measurement value.</p>
<p>4. Output 1 zero correction</p> <div style="border: 1px solid black; padding: 5px; margin: 5px 0;"> <p>USER CAL OUT1 ZERO = 00.000</p> </div>	<p>① Output format of output 1 displays current output format or voltage output format only.</p> <p>② It is a function that does the zero correction (bias operation) of output 1.</p> <p>③ '0.0' being the standard, if minus value is set, it indicates low output value. If plus value is set, it indicates high output value.</p>
<p>5. Output 1 span correction</p> <div style="border: 1px solid black; padding: 5px; margin: 5px 0;"> <p>USER CAL OUT1 SPAN = 1.0000</p> </div>	<p>① Output format of output 1 displays current output format or voltage output format only.</p> <p>② It is a function that does the span correction (coefficient calculation) of output 1.</p> <p>③ '1.0' being the standard, if a small value is set tilting becomes smaller indicating lower output value. On the other hand if a large value is set, the tilting is bigger indicating higher output value.</p>

<p>6. Output 2 zero correction</p> <pre style="border: 1px solid black; padding: 5px;"> USER CAL OUT2 ZERO = 00.000 </pre>	<ol style="list-style-type: none"> ① Output format of output 2 displays current output format or voltage output format only. ② It is a function that does the zero correction (bias operation) of output 2. ③ '0.0' being the standard, if minus value is set, it indicates low output value. If plus value is set, it indicates high output value.
<p>7. Output 2 span correction</p> <pre style="border: 1px solid black; padding: 5px;"> USER CAL OUT2 SPAN = 1.0000 </pre>	<ol style="list-style-type: none"> ① Output format of output 2 displays current output format or voltage output format only. ② It is a function that does the span correction (coefficient calculation) of output 2 side. ③ '1.0' being the standard, if a small value is set tilting becomes smaller indicating lower output value. On the other hand if a large value is set, the tilting is bigger indicating higher output value.
<p>8. Remote input zero correction</p> <pre style="border: 1px solid black; padding: 5px;"> USER CAL REMOTE ZERO = 00.000 </pre>	<ol style="list-style-type: none"> ① Only the instrument with remote signal input is displayed. ② It is a function that does the zero correction (bias operation) of remote signal input. ③ '0.0' being the standard, if minus value is set, it indicates low indicating value. If plus value is set, it indicates high indicating value.
<p>9. Remote input span correction</p> <pre style="border: 1px solid black; padding: 5px;"> USER CAL REMOTE SPAN = 1.0000 </pre>	<ol style="list-style-type: none"> ① Only the instrument with remote signal input is displayed. ② It is a function that does the span correction (coefficient calculation) of remote signal input. ③ '1.0' being the standard, if a small value is set tilting becomes smaller indicating lower indicating value. On the other hand if a large value is set, the tilting is bigger indicating higher indicating value.
<p>10. Transmission output zero correction (High-performance type)</p> <pre style="border: 1px solid black; padding: 5px;"> USER CAL TRANS(H) ZERO = 00.000 </pre>	<ol style="list-style-type: none"> ① Only the instrument with transmission signal output (High performance type) is displayed. ② It is function that does the zero correction (bias operation) of transmission output (High performance type). ③ '0.0' being the standard, if minus value is set, it indicates low output value. If plus value is set, it indicates high output value.
<p>11. Transmission output span correction (High-performance type)</p> <pre style="border: 1px solid black; padding: 5px;"> USER CAL TRANS(H) SPAN = 1.0000 </pre>	<ol style="list-style-type: none"> ① Only the instrument with transmission signal output (High performance type) is displayed. ② It is function that does the span correction (coefficient calculation) of transmission output (High performance type). ③ '1.0' being the standard, if a small value is set tilting becomes smaller indicating lower output value. On the other hand if a large value is set, the tilting is bigger indicating higher output value.
<p>12. Transmission output zero correction (General type)</p> <pre style="border: 1px solid black; padding: 5px;"> USER CAL TRANS(N) ZERO = 00.000 </pre>	<ol style="list-style-type: none"> ① Only the instrument with transmission signal output (General type) is displayed. ② It is a function that does the zero correction (bias operation) of transmission output (General type). ③ '0.0' being the standard, if minus value is set, it indicates low output value. If plus value is set, it indicates high output value.

<p>13. Transmission output span correction (General type)</p> <pre style="border: 1px solid black; padding: 5px;">USER CAL TRANS(N) SPAN = 1.0000</pre>	<ol style="list-style-type: none"> ① Only the instrument with transmission signal output (General type) is displayed. ② It is a function that does the span correction (coefficient calculation) of transmission output (General type). ③ '1.0' being the standard, if a small value is set tilting becomes smaller indicating lower output value. On the other hand if a large value is set, the tilting is bigger indicating higher output value.
<p>14. CT input zero correction</p> <pre style="border: 1px solid black; padding: 5px;">USER CAL CT ZERO = 00.000</pre>	<ol style="list-style-type: none"> ① Only the instrument with heater snapping wire alarm is displayed. ② It is a function that does the zero correction (Bias operation) of CT input. ③ '0.0' being the standard, if minus value is set, it indicates low measurement value. If plus value is set, it indicates high measurement value.
<p>15. CT input span correction</p> <pre style="border: 1px solid black; padding: 5px;">USER CAL CT SPAN = 1.0000</pre>	<ol style="list-style-type: none"> ① Only the instrument with heater snapping wire alarm is displayed. ② It is a function that does the span correction (Coefficient calculation) of CT input. ③ '1.0' being the standard, if a small value is set tilting becomes smaller indicating lower indicating value. On the other hand if a large value is set, the tilting is bigger indicating higher indicating value.

7-12. Initializing the setup parameter

If set contents are to be returned to initial value, you can do it by the following procedure. There are two types of initializations and you can select from them. Once initialization is executed, you will not be able to return to the original setting contents hence take care.

Initialization type	Procedure	Screen that is being initialized
<p>1. Initializing the basic setting contents (Mode 0 to Mode 11)</p>	<ol style="list-style-type: none"> ① Cut off the power supply. ② Switch on the power supply while pressing the MODE key. ③ After confirming that the screen shown on the right is displayed, release the MODE key. ④ After the initialization is done, operation screen is displayed. 	<pre style="border: 1px solid black; padding: 10px; text-align: center;">Parameter Initialize</pre>
<p>2. Initializing all the setting contents (Mode 0 to Mode 12)</p>	<ol style="list-style-type: none"> ① Cut off the power supply. ② Switch on the power supply while pressing the MODE key and EXIT key. ③ After confirming that the screen shown on the right is displayed, release the MODE key and EXIT key. ④ After the initialization is done, operation screen is displayed. 	<pre style="border: 1px solid black; padding: 10px; text-align: center;">All Parameter Initialize</pre>

* 'External signal allocation' is not initialized.



7-13. Precautions while setting

Precautions	Explanation
1. Precautions regarding the setting range.	<ul style="list-style-type: none"> • In parameter for numeric settings, there exists a range of numbers that can be set, hence take care. • For example, the 'SV range' of mode 2 becomes the numeric value range, set in 'scaling' or 'measurement range' of mode 5. • If you try to set a numeric value exceeding the numeric value range that can be set, an error message is displayed. When an error message is displayed confirm the contents of the error message and do the proper settings.
2. When a setting is changed, the set contents of other settings screen may sometimes change.	<ul style="list-style-type: none"> • If the setting of important key parameters is changed, the decimal point position or the setting range of the set value of other related settings screen may sometimes change or may be initialized. • For example if 'measurement range', 'measurement scope', 'linear scale' of mode 5, 'alarm format' of mode 3, transmission type' of mode 6 etc. is changed, the set contents of the other settings screen related to them will change. • If the settings of these key parameters is changed, reconfirm the set contents of other settings screen.

7-14. Error message

7-14-1. Usual error display

If proper settings and operation is not done, following error messages are displayed for around 3 seconds. Confirm the contents of the error message and do the proper settings and operation again.

Error message	Error contents
1. 	<ul style="list-style-type: none"> • SV is exceeding the measurement range. • Confirm the measurement range and do the settings again.
2. 	<ul style="list-style-type: none"> • Out of scope of SV section of PIDNo.9. • Do the settings again after confirming the SV section.

<p>3.</p> <div style="border: 1px solid black; padding: 5px; width: fit-content;"> ERROR No. 2 1 INVERTED L > H </div>	<ul style="list-style-type: none"> ▪ L is exceeding H. ▪ Confirm L/H and do the settings again.
<p>4.</p> <div style="border: 1px solid black; padding: 5px; width: fit-content;"> ERROR No. 2 4 INVERTED Z > S </div>	<ul style="list-style-type: none"> ▪ Z is exceeding S. ▪ Confirm Z/S and do the settings again.
<p>5.</p> <div style="border: 1px solid black; padding: 5px; width: fit-content;"> ERROR No. 2 5 LINEAR RANGE OVER </div>	<ul style="list-style-type: none"> ▪ Linear range is exceeding the scope of measurement range. ▪ Confirm the measurement range and do the settings again.
<p>6.</p> <div style="border: 1px solid black; padding: 5px; width: fit-content;"> ERROR No. 2 6 SV LIMIT OVER </div>	<ul style="list-style-type: none"> ▪ SV is exceeding the limit value. ▪ Do the settings again after confirming the setting value.
<p>7.</p> <div style="border: 1px solid black; padding: 5px; width: fit-content;"> ERROR No. 6 5 AT1: ONLY RUN </div>	<ul style="list-style-type: none"> ▪ AT1 is not start because of not operation (RUN) mode ▪ Set the operation (RUN) mode and start AT1.
<p>8.</p> <div style="border: 1px solid black; padding: 5px; width: fit-content;"> ERROR No. 7 8 AT2: ONLY READY </div>	<ul style="list-style-type: none"> ▪ AT2 is not start because of not READY condition ▪ Set the READY condition and start AT2.
<p>9.</p> <div style="border: 1px solid black; padding: 5px; width: fit-content;"> ERROR No. 7 9 AT3: ONLY READY </div>	<ul style="list-style-type: none"> ▪ AT3 is not start because of not READY condition. ▪ Set the READY condition and start AT3.
<p>10.</p> <div style="border: 1px solid black; padding: 5px; width: fit-content;"> ERROR No. 7 6 AT4: ONLY RUN </div>	<ul style="list-style-type: none"> ▪ AT4 is not start because of not operation (RUN) mode. ▪ Set the operation (RUN) mode and start AT4.

7-14-2. System error display

If an abnormality occurs in the system, the following error messages are displayed for around 2 seconds. Confirm the contents of the error message and contact the dealer or our nearest office.

Error message	Error contents
1. <div style="border: 1px solid black; padding: 5px; width: fit-content; margin: 10px auto;"> SYSTEM ERROR No. 01 CALIBRATION ERROR </div>	<ul style="list-style-type: none"> ▪ Calibration data abnormality
2. <div style="border: 1px solid black; padding: 5px; width: fit-content; margin: 10px auto;"> SYSTEM ERROR No. 10 A/D COUNT : PV </div>	<ul style="list-style-type: none"> ▪ Abnormality in A/D conversion for PV
3. <div style="border: 1px solid black; padding: 5px; width: fit-content; margin: 10px auto;"> SYSTEM ERROR No. 11 A/D COUNT : RJ </div>	<ul style="list-style-type: none"> ▪ Abnormality in A/D conversion for RJ
4. <div style="border: 1px solid black; padding: 5px; width: fit-content; margin: 10px auto;"> SYSTEM ERROR No. 16 A/D COUNT : REMOTE </div>	<ul style="list-style-type: none"> ▪ Abnormality in A/D conversion for remote

7-13-3. Warning display

If proper settings and operation is not done, following error messages are displayed for around 3 seconds. Confirm the contents of the warning message and do the proper settings and operation again.

Warning message	Warning contents
1. <div style="border: 1px solid black; padding: 5px; width: fit-content; margin: 10px auto;"> WARNING No. 10 KEY LOCK </div>	<ul style="list-style-type: none"> ▪ Setting is not changed because of the [Lock] condition at the mode screen. ▪ Change the setting after canceling the [Lock] condition.

8. Initial settings

In '7. Setting screen' setting screen for each mode is explained, but you need not set all of them. The customer should select and set the required parameters depending on the specifications of the controller, system configuration of final product, control conditions etc.

Procedure for setting the minimum limit which is always to be done in the beginning for the final product is explained here. Do the other settings as per the requirement.



: Always set



: Set as per the requirement

① Set 'measurement range' : Mode 5

※Set the measurement range that suits the sensor and the scale range.



② Set 'measurement scope' : Mode 5

※Set the range that is to be actually used. For linear input, set standard range. In case of thermocouple and resistance initial value is also okay.



③ Setting 'linear scale' : Mode 5

※ Set the controlling operation.



④ Setting 'Direct/reverse' of controlling operation : Mode 4

※Set the scale for linear input.



⑤ Setting 'SV' : Mode 2

※ Set SV.



⑥ Setting 'PID' : Mode 3

※ Set PID.



⑦ Switching to 'RUN' : Mode 1

※ Confirm the RUN condition

9. Operation

9-1. Confirmations before operation

Confirm the following contents before starting the operation.

Item	Confirmation contents
1. Wiring	<ul style="list-style-type: none">• Confirm that the wiring is correct. Especially confirm very properly the wiring of high voltage parts like power supply, output and alarm. Confirm that the terminal screw is not loose.• Confirm the wiring of not only the controller but also of the entire final product. Especially proper confirmation of peripherals of actuator (thyristor regulator, heater, motor etc.) product is important.
2. Power supply	<ul style="list-style-type: none">• Confirm that the power supply is in the rating range.
3. Set contents	<ul style="list-style-type: none">• Confirm that the set contents are correct. As soon as the power supply is started the control action starts. As per the requirement if you do not want to display the output, set something like 0% in READY status or in manual output operation.

 Precautions	<ul style="list-style-type: none">① If power supply that is out of rating range is connected, the product may get out of order, performance may deteriorate or it may malfunction.② If excess voltage or excess current is applied to input/output terminal of the controller, the product may get out of order, performance may deteriorate or it may malfunction.
--	--

9-2. Trial operation

After the confirmations before operation is done, refer to the following and start the trial operation and do various confirmations. This procedure is an example of the most basic trial operation procedure. Add the confirmation contents depending on specifications of the controller, system configuration of final product, control conditions etc.

① Start the power supply. Preferably, considering the safety make the output as 0% in READY status when power supply is started or make the status as output 0% in manual output operation such that the control output of the controller becomes 0%.



② Confirm that the device configuring the system that includes the controller also, is normal.





③ Confirm that all the signal levels (voltage value, current value, ON/OFF signal etc.) connected between the device configuring the system that includes the controller also, is normal.



④ When output format is current format and thyristor regulator is connected as actuator, and confirm the setting contents of thyristor regulator. When output format connects the motor as actuator, in ON-OFF servo type, do the actuator adjustment (FB zero span settings). In other output format also, confirm the actuator and do the adjustment as per the requirement]



⑤ The controller is in RUN status and status of output is 0 due to manual output operation. Confirm that output increases little by little, and that the movement of the actuator is equivalent to the output value and is normal.



⑥ Set appropriate SV, switch over from manual output operation to automatic output operation and get the auto control status.



⑦ See the status for a while and if the control is stable then there is no problem. However if the control is unstable, adjust the parameters (PID etc.) etc. of the controller. PID can be calculated automatically also by using the auto tuning function.



⑧ Confirm that operation (Alarm, external signal input etc.) with peripheral device that is connected to the controller is normal.



⑨ Set each type of parameter of the controller as per the requirement.







⑩ After some time of starting the operation confirm the normality of final product that includes the controller and all the devices configuring the system.

9-3. RUN status and READY status

Status mode	Description
RUN status	<ul style="list-style-type: none"> • In this status the operation is performed. • Operation is classified into two type automatic output operation and manual output operation. • In case of RUN status, 'RUN' in the upper display is illuminated.
READY status	<ul style="list-style-type: none"> • In this status (Idling status) operation is not performed. • Output value becomes the setting value of preset manual of mode 4. • Alarm operation is not executed. • Auto tuning cannot be executed. • Switching between RUN/READY is done by mode 1 or as per the specification it can also be done by external signal input. • In case of READY status, 'READY' in the upper display illuminates.

9-4. Automatic output operation and manual output operation

Operation method	Explanation
Automatic output operation (Auto output)	<ul style="list-style-type: none"> • Based on SV of the execution number that is selected and also on the PV that is being measured, perform the control calculation, calculate the control output value and output it. • Usual control action is this automatic output operation.
Manual output operation (Manual output)	<ul style="list-style-type: none"> • SV and PV output the control output value that is set irrespective of each other. • If you want to switch to manual output operation click the  key and the  key in the operation screen or as per the specifications, switching can also be done by external signal input. • Set the output value by  key/ key. Output range is within the output limit range. • During automatic/manual switching, the output value does not change suddenly because of balance less bump less function. • During manual output operation, 'M' is added before the word 'OUT' of the operation screen. • Do not switch from manual output to preset manual. • In case of output 2 specifications, switching between automatic/manual can be done separately for operation screen of output 1 side and that of output 2 side. • It is popularly called as manual output.

9-5. Precautions during operation

9-5-1. Change in settings during operation

When changing the settings during operation, any of the settings screen can also be changed. However changing the settings during control action by using parameter, may adversely affect the control, hence take care.

9-5-2. Precautions when power supply is started

1. P (proportion) operation when starting the power supply

Even though the settings of PID control are done, only the initial control action at the time of power supply becomes the P (proportion) operation. As a result, due to the conditions the output value becomes very big momentarily during the power supply, hence take care.

2. Countermeasures against the erroneous output during power supply

During the power supply, until the controller starts normally, output related signals may be momentarily output sometimes. Implement the countermeasures against erroneous output as per the requirement, by using external circuit.

3. Precautions in case of momentary power cut off

When power supply is started again, operation status is depends on the settings of 'Operation when power supply is started' of mode 1.

When 'CONTINUE' is selected, one returns to the status at the time of power supply cut off. In other words, if status is RUN at the time of power cut off then it remains RUN and if it is READY at that time it remains READY. When 'READY' is selected, even if the status is 'RUN' in the setting screen and external signal input, the status is always 'READY'. At that time if the RUN status in the setting screen and external signal input is returned to READY once, and then by changing it to RUN again, the status becomes RUN. Especially when using external signal input take care about the sequence.

Even though the power supply cut off/start does not take place due to operation by the customer or due to final product sequence, there is a temporary power cut off/start due to some reason, and even when the controller detects the power supply cut off/start, the operation is performed based on the settings of 'Operation at the time of starting the power supply' of mode 1. For example if a good quality power supply is not used, if 'READY' is selected when a momentary power cut off etc. takes place, unknowingly the status becomes 'READY' status, hence take care. Do not select 'READY' as it adversely affects the entire system of the final product when power supply is not stable.

9-5-3. Precautions during operations of SV slope

During operations of SV slope, the [SLOPE] in the upper display is lighted, and SV is changed with time. Maximum 5 digits of SV are displayed, so that precise operations of SV including decimal point are not displayed. Margin of error of plus or minus 1 digit maximum is observed on the display. However, accurate control calculation is performed in internal processing. The time accuracy of the operation of SV slope is not accuracy at clock level.



Precautions

- ① Take care while changing the settings during operation. It may badly affect the 'control by parameters'.
- ② Supply a good quality and a stable power supply. The controller may malfunction unexpectedly when it is adversely affected by noise, temporary power cut off etc.

10. Detailed explanation of main functions

10-1 Measurement range

The controller is a universal input type or a 4-wire resistance thermometer type and has various measurement ranges. From among them, select the appropriate measurement range from the sensor and the scale range that is to be actually used. For thermocouple and resistance thermometer, confirm the standards and then select the measurement range. Especially 'Pt100Ω' system of resistance thermometer has three types of ratings hence take care.

Displayed measurement range which is set at [measurement range] of mode 5 may be not in order.

[Universal]

No.	Measurement range	Scale range (°C)	Scale range (K)	No.	Measurement range	Scale range (°C)	Scale range (K)		
01	Thermocouple	B	0.0 to 1820.0	273.0 to 2093.0	25	Thermocouple	Plati II 1	0.0 to 1390.0	273.0 to 1663.0
02		R1	0.0 to 1760.0	273.0 to 2033.0	26		Plati II 2	0.0 to 600.0	273.0 to 873.0
03		R2	0.0 to 1200.0	273.0 to 1473.0	27		U	-200.0 to 400.0	73.0 to 673.0
04		S	0.0 to 1760.0	273.0 to 2033.0	28		L	-200.0 to 900.0	73.0 to 1173.0
05		K1	-200.0 to 1370.0	73.0 to 1643.0	31	DC voltage	10mV	±10mV	
06		K2	0.0 to 600.0	273.0 to 873.0	32		20mV	±20mV	
07		K3	-200.0 to 300.0	73.0 to 573.0	33		50mV	±50mV	
08		E1	-270.0 to 1000.0	3.0 to 1273.0	34		100mV	±100mV	
09		E2	0.0 to 700.0	273.0 to 973.0	35		5V	±5V	
10		E3	-270.0 to 300.0	3.0 to 573.0	37		10V	±10V	
11		E4	-270.0 to 150.0	3.0 to 423.0	36	DC current	20mA	0 to 20mA	
12		J1	-200.0 to 1200.0	73.0 to 1473.0	41	Resistance	JPt100Ω1	-200.0 to 649.0	73.0 to 922.0
13		J2	-200.0 to 900.0	73.0 to 1173.0	42		JPt100Ω2	-200.0 to 400.0	73.0 to 673.0
14		J3	-200.0 to 400.0	73.0 to 673.0	44		JPt100Ω4	-200.0 to 200.0	73.0 to 473.0
15		J4	-100.0 to 200.0	173.0 to 473.0	45		JPt100Ω5	-100.0 to 100.0	173.0 to 373.0
16		T1	-270.0 to 400.0	3.0 to 673.0	46		QPt100Ω1	-200.0 to 649.0	73.0 to 922.0
17		T2	-200.0 to 200.0	73.0 to 473.0	47		QPt100Ω2	-200.0 to 400.0	73.0 to 673.0
18		WRe5-26	0.0 to 2310.0	273.0 to 2583.0	49		QPt100Ω4	-200.0 to 200.0	73.0 to 473.0
19		W-WRe26	0.0 to 2310.0	273.0 to 2583.0	50		QPt100Ω5	-100.0 to 100.0	173.0 to 373.0
20		NiMo-Ni	-50.0 to 1410.0	223.0 to 1683.0	51		JPt50Ω	-200.0 to 649.0	73.0 to 922.0
21		CR-AuFe	0.0 to 280.0 K	0.0 to 280.0	53		Pt100Ω1	-200.0 to 850.0	73.0 to 1123.0
22		N	0.0 to 1300.0	273.0 to 1573.0	54		Pt100Ω2	-200.0 to 400.0	73.0 to 673.0
23		PR5-20	0.0 to 1800.0	273.0 to 2073.0	56		Pt100Ω4	-200.0 to 200.0	73.0 to 473.0
24		PtRh40-20	0.0 to 1880.0	273.0 to 2153.0	57	Pt100Ω5	-100.0 to 100.0	173.0 to 373.0	

[4-wire resistance thermometer]

No.	Measurement range	Scale range (°C)	Scale range (K)	No.	Measurement range	Scale range (°C)	Scale range (K)		
41	Resistance	JPt100Ω1	-200.0 to 649.0	73.0 to 922.0	50	Resistance	QPt100Ω5	-100.0 to 100.0	173.0 to 373.0
42		JPt100Ω2	-200.0 to 400.0	73.0 to 673.0	51		JPt50Ω	-200.0 to 649.0	73.0 to 922.0
44		JPt100Ω4	-200.0 to 200.0	73.0 to 473.0	52		Pt-Co	4.0 to 374.0 K	4.0 to 374.0
45		JPt100Ω5	-100.0 to 100.0	173.0 to 373.0	53		Pt100Ω1	-200.0 to 850.0	73.0 to 1123.0
46		QPt100Ω1	-200.0 to 649.0	73.0 to 922.0	54		Pt100Ω2	-200.0 to 400.0	73.0 to 673.0
47		QPt100Ω2	-200.0 to 400.0	73.0 to 673.0	56		Pt100Ω4	-200.0 to 200.0	73.0 to 473.0
49		QPt100Ω4	-200.0 to 200.0	73.0 to 473.0	57		Pt100Ω5	-100.0 to 100.0	173.0 to 373.0

- K, E, J, T, R, S, B, N: IEC584 (1977, 1982), JIS C 1602-1995
- WRe5-WRe26, W-WRe26, NiMo-Ni, PtRh40-PtRh20, Platinel II : ASTM Vol.14.03
- U, L: DIN43710-1985
- JPt100Ω: JIS C 1604-1981, JIS C 1606-1986
- QPt100Ω: IEC751 (1983), JIS C 1604-1989, JIS C 1606-1989
- ※QPt100Ω is also called old PT100Ω.
- Pt100Ω: IEC751 (1995), JIS C 1604-1997

10-2. Linear scale

If linear input (DC current and DC voltage) is selected, then measurement scope and initial value of linear scale is as follows.

Measurement range	Scale range	Measurement scope (Initial value)	Linear scale (Initial value)
31 10mV	- 10.0 to 10.0 mV	0.00 to 10.00 mV	0.0 to 2000.0
32 20mV	- 20.0 to 20.0 mV	0.00 to 20.00 mV	0.0 to 2000.0
33 50mV	- 50.0 to 50.0 mV	0.00 to 50.00 mV	0.0 to 2000.0
34 100mV	-100.0 to 100.0 mV	0.0 to 100.0 mV	0.0 to 2000.0
35 5V	-5.0 to 5.0 V	0.000 to 5.000 V	0.0 to 2000.0
37 10V	-10.0 to 10.0 V	0.000 to 10.000 V	0.0 to 2000.0
36 20mA	0.0 to 20.0 mA	4.00 to 20.00 mA	0.0 to 2000.0

Setting procedure is as follows.

- ① For 'measurement scope' of mode 5, set the minimum value and the maximum value of the analog signal that is actually input from the sensor.
- ② Nextly for 'linear scale' of mode 5, after confirming how to display that minimum value and maximum value set the decimal point position and lower limit and upper limit of the scale.
- ③ For example, for 4-20 mA if you want to display 0.00-100.00, the settings are as follows.
 - Measurement scope : 4.000 (minimum value) – 20.000 (Maximum value).
 - Linear scale : DOT2.
0.00 (Lower limit) -100.00 (Higher limit).

10-3. Alarm mode

Following are the types of alarm formats.

- ① PV (Measurement value) alarm
 - PV(Absolute value alarm) : PV alarm due to alarm setting value.
 - DV(Deviation alarm) : PV alarm due to SV + alarm setting value.
 - ADV(Absolute value deviation alarm) : PV alarm due to SV ± alarm setting value.
× Set integer number (absolute value) for alarm value.
- ② SV (Setting value) alarm
 - SV(Setting value alarm) : SV alarm due to alarm setting value.
- ③ MV (Output value) alarm
 - MV (Output value alarm) : MV alarm due to alarm settings value.
× In case of output 2 specifications, output value(MV1) alarm on the output 1 side rings.
- ④ Control related alarm
 - CT (Heater snapping value alarm) : CT measurement value alarm due to alarm settings value.
× Only the specifications with heater snapping wire alarm can be selected.
 - LOOP (Control loop abnormal alarm) : Control loop alarm due to alarm setting value.
× Only output 1 specifications can be selected.
- ⑤ FAIL (abnormal) alarm
 - FAIL(Fail alarm) : RJ data abnormal, A/D conversion abnormal
× Setting value does not exist.
- ⑥ Timer
 - TIMER : Timer combined with external signal input.
× Only specifications with external signal input can be selected.

In the alarm format from ① to ③ mentioned above, select the following conditions.

- H (High limit alarm) : If alarm setting value is exceeded alarm gets switched ON.
- L (Low limit alarm) : If alarm setting value is less alarm gets switched ON.
- HW (Wait high limit alarm) : In a system that has wait function in high limit alarm, keep the alarm ON in wait status until it once enters the normal range after the power supply is started.
- LW (Wait low limit alarm) : In a system that has wait function in low limit alarm, keep the alarm ON in wait status until it once enters the normal range after the power supply is started.
- HK (Maintenance high limit alarm) : In a system that has maintenance function in high limit alarm, the alarm ON status is maintained from the time when alarm is switched ON to the time when it is cancelled.
× Alarm is cancelled by alarm output cancellation, switching to READY from RUN, or OFF/ON of power.
- LK (Maintenance low limit alarm) : In a system that has maintenance function in low limit alarm, the alarm ON status is maintained from the time when alarm is switched ON to the time when it is cancelled.
× Alarm is cancelled by alarm output cancellation, switching to READY from RUN, or OFF/ON of power.
- HWK (Wait maintenance high limit alarm) : It is a system that has wait function and maintenance function in high limit alarm.
- LWK (Wait maintenance low limit alarm) : It is a system that has wait function and maintenance function in low limit alarm.

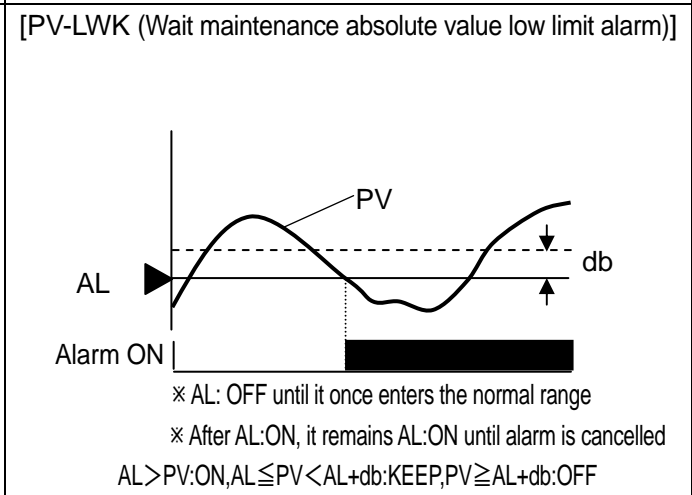
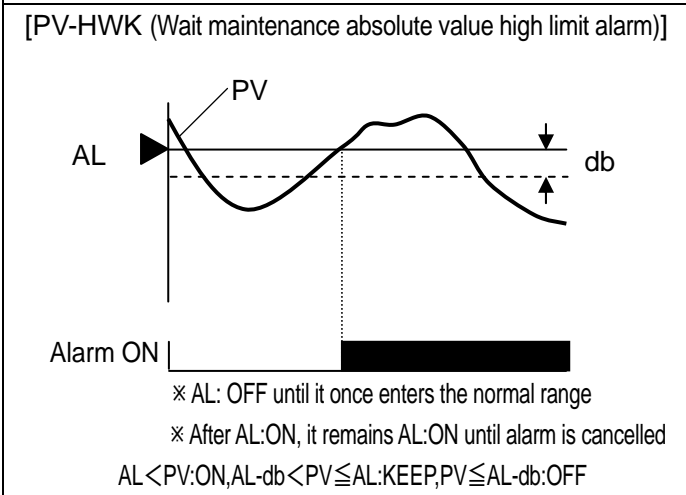
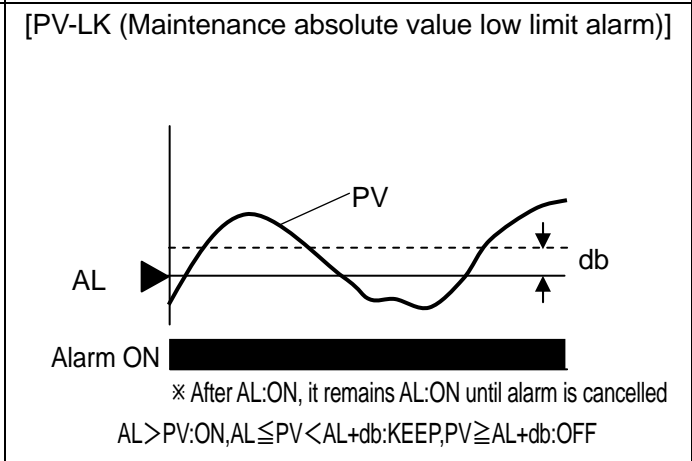
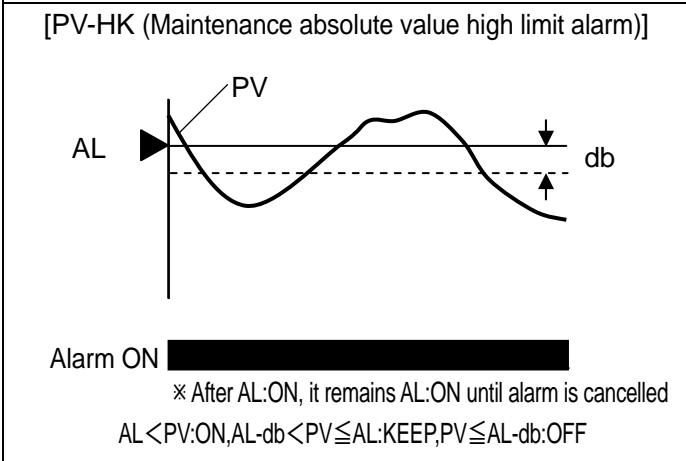
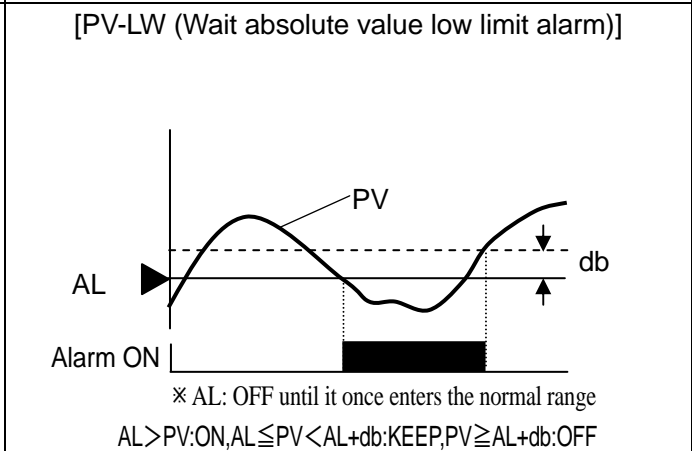
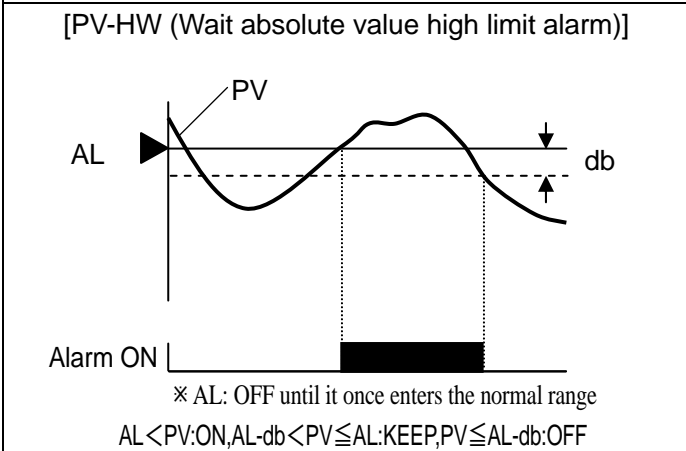
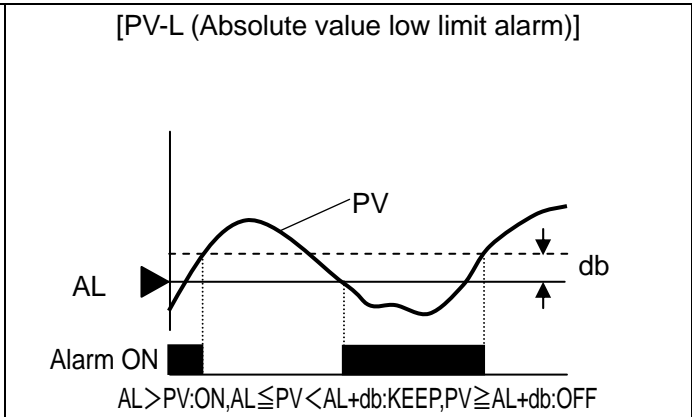
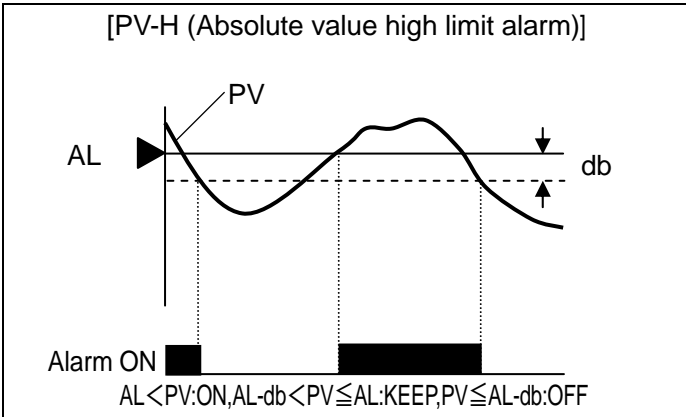

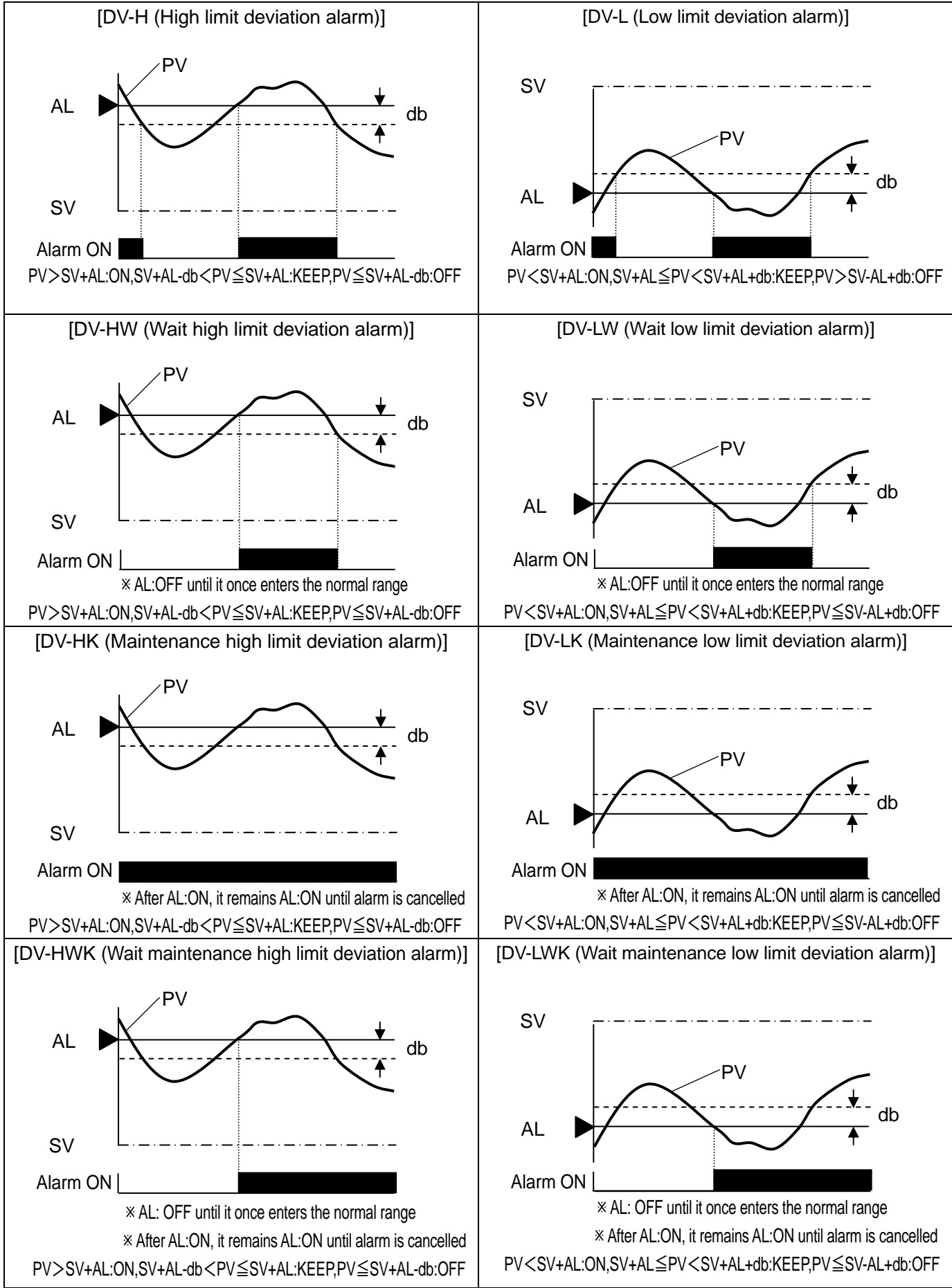

[ADV-H (Absolute value high limit deviation alarm)]

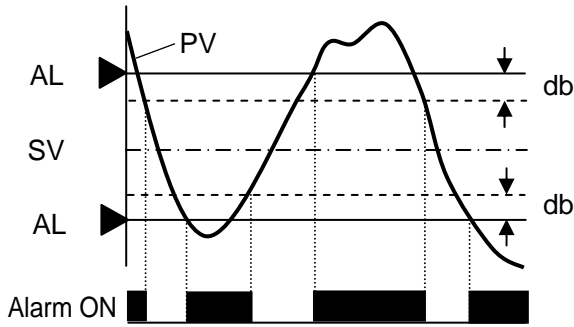

PV > SV + AL: ON, PV < SV - AL: ON, SV + AL - db ≤ PV ≤ SV + AL: KEEP
 SV - AL ≤ PV ≤ SV - AL + db: KEEP, PV < SV + AL - db: OFF, PV > SV - AL + db: OFF

[ADV-L (Absolute value low limit deviation alarm)]

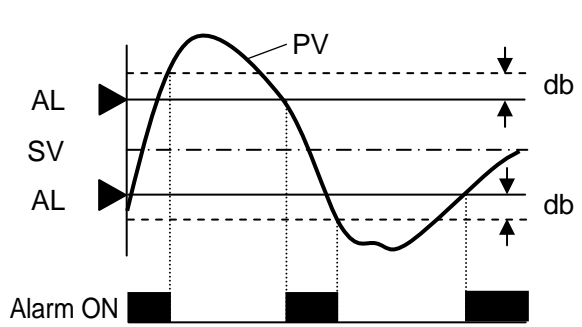

SV - AL < PV < SV + AL: ON, SV + AL ≤ PV ≤ SV + AL + db: KEEP
 SV - AL - db ≤ PV ≤ SV - AL: KEEP, PV > SV + AL + db: OFF, PV < SV - AL - db: OFF

[ADV-HW (Wait absolute value high limit deviation alarm)]

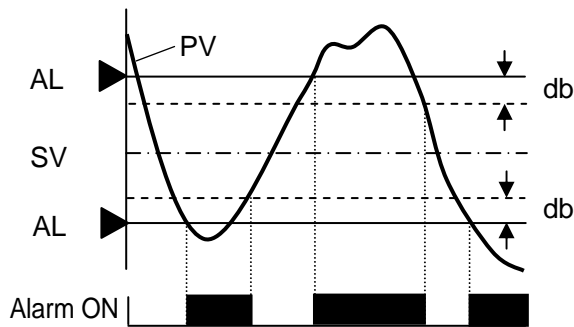

※ AL: OFF until it once enters the normal range

PV > SV + AL: ON, PV < SV - AL: ON, SV + AL - db ≤ PV ≤ SV + AL: KEEP
 SV - AL ≤ PV ≤ SV - AL + db: KEEP, PV < SV + AL - db: OFF, PV > SV - AL + db: OFF

[ADV-LW (Wait absolute value low limit deviation alarm)]

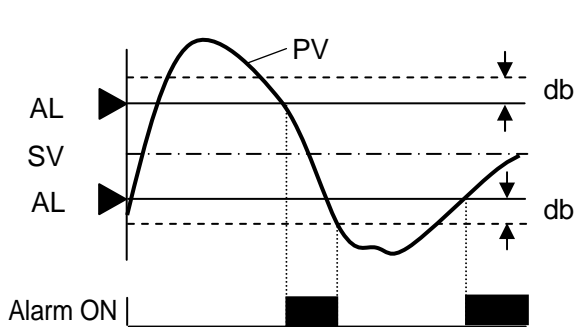

※ AL: OFF until it once enters the normal range

SV - AL < PV < SV + AL: ON, SV + AL ≤ PV ≤ SV + AL + db: KEEP
 SV - AL - db ≤ PV ≤ SV - AL: KEEP, PV > SV + AL + db: OFF, PV < SV - AL - db: OFF

[ADV-HK (Wait absolute value high limit deviation alarm)]

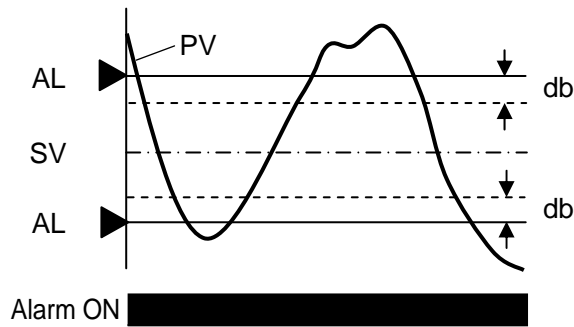

※ After AL: ON, it remains AL: ON until alarm is cancelled

PV > SV + AL: ON, PV < SV - AL: ON, SV + AL - db ≤ PV ≤ SV + AL: KEEP
 SV - AL ≤ PV ≤ SV - AL + db: KEEP, PV < SV + AL - db: OFF, PV > SV - AL + db: OFF

[ADV-LK (Wait absolute value low limit deviation alarm)]

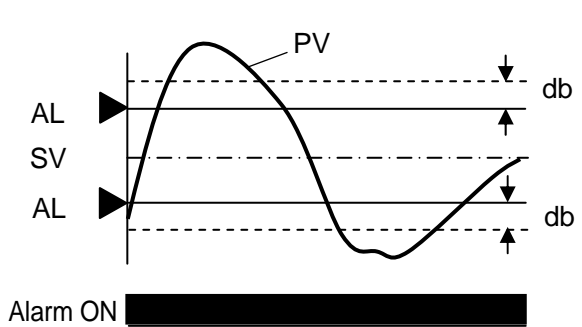

※ After AL: ON, it remains AL: ON until alarm is cancelled

SV - AL < PV < SV + AL: ON, SV + AL ≤ PV ≤ SV + AL + db: KEEP
 SV - AL - db ≤ PV ≤ SV - AL: KEEP, PV > SV + AL + db: OFF, PV < SV - AL - db: OFF

[ADV-HWK (Wait maintenance absolute value high limit deviation alarm)]

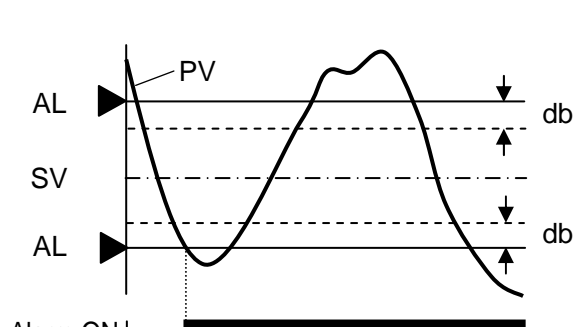

※ AL: OFF until it once enters the normal range

※ After AL: ON, it remains AL: ON until alarm is cancelled

PV > SV + AL: ON, PV < SV - AL: ON, SV + AL - db ≤ PV ≤ SV + AL: KEEP
 SV - AL ≤ PV ≤ SV - AL + db: KEEP, PV < SV + AL - db: OFF, PV > SV - AL + db: OFF

[ADV-LWK (Wait maintenance absolute value low limit deviation alarm)]

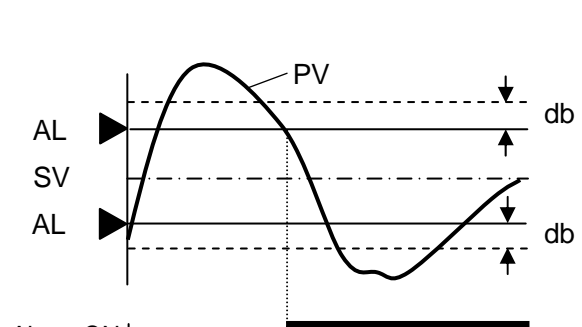

※ AL: OFF until it once enters the normal range

※ After AL: ON, it remains AL: ON until alarm is cancelled

SV - AL < PV < SV + AL: ON, SV + AL ≤ PV ≤ SV + AL + db: KEEP
 SV - AL - db ≤ PV ≤ SV - AL: KEEP, PV > SV + AL + db: OFF, PV < SV - AL - db: OFF

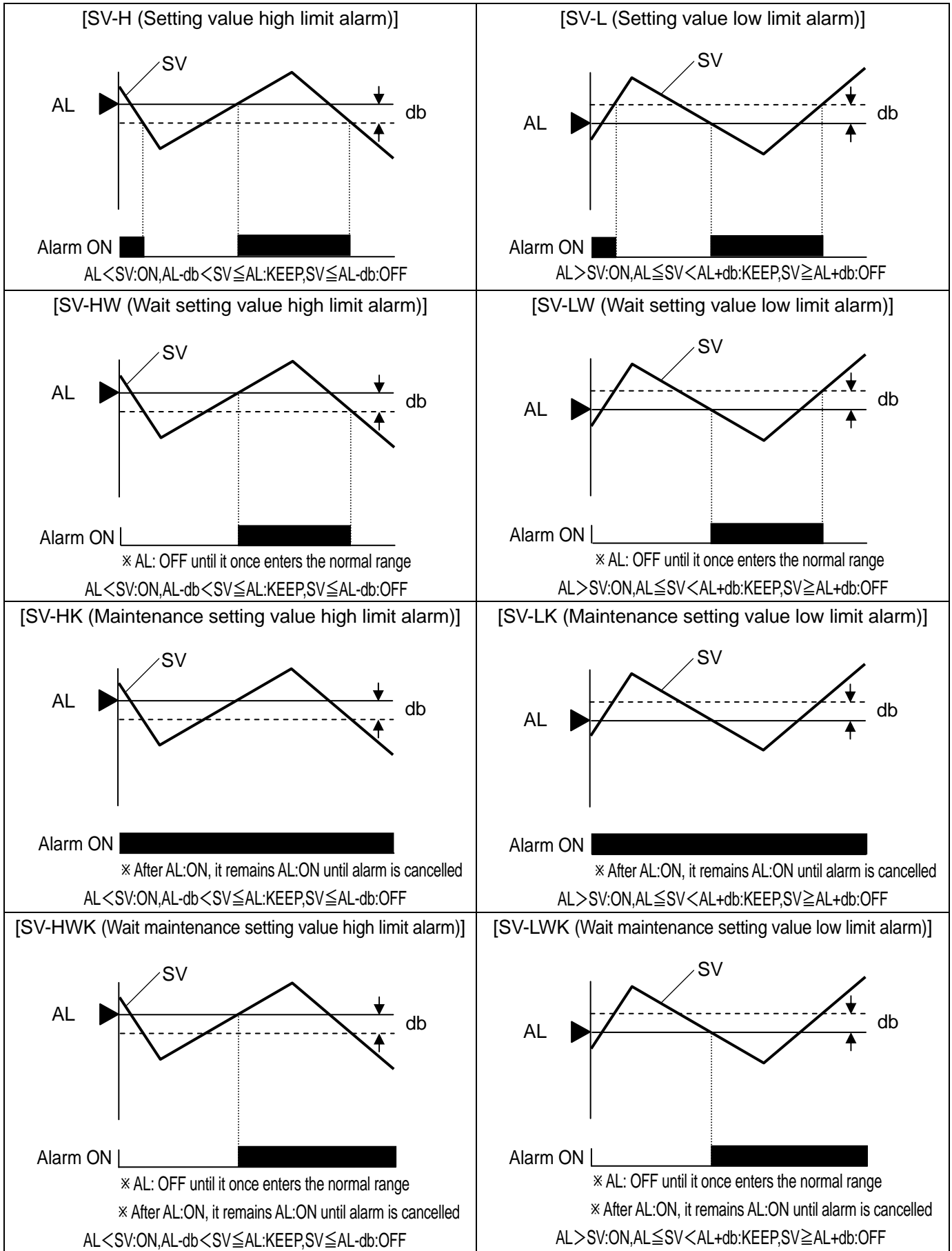

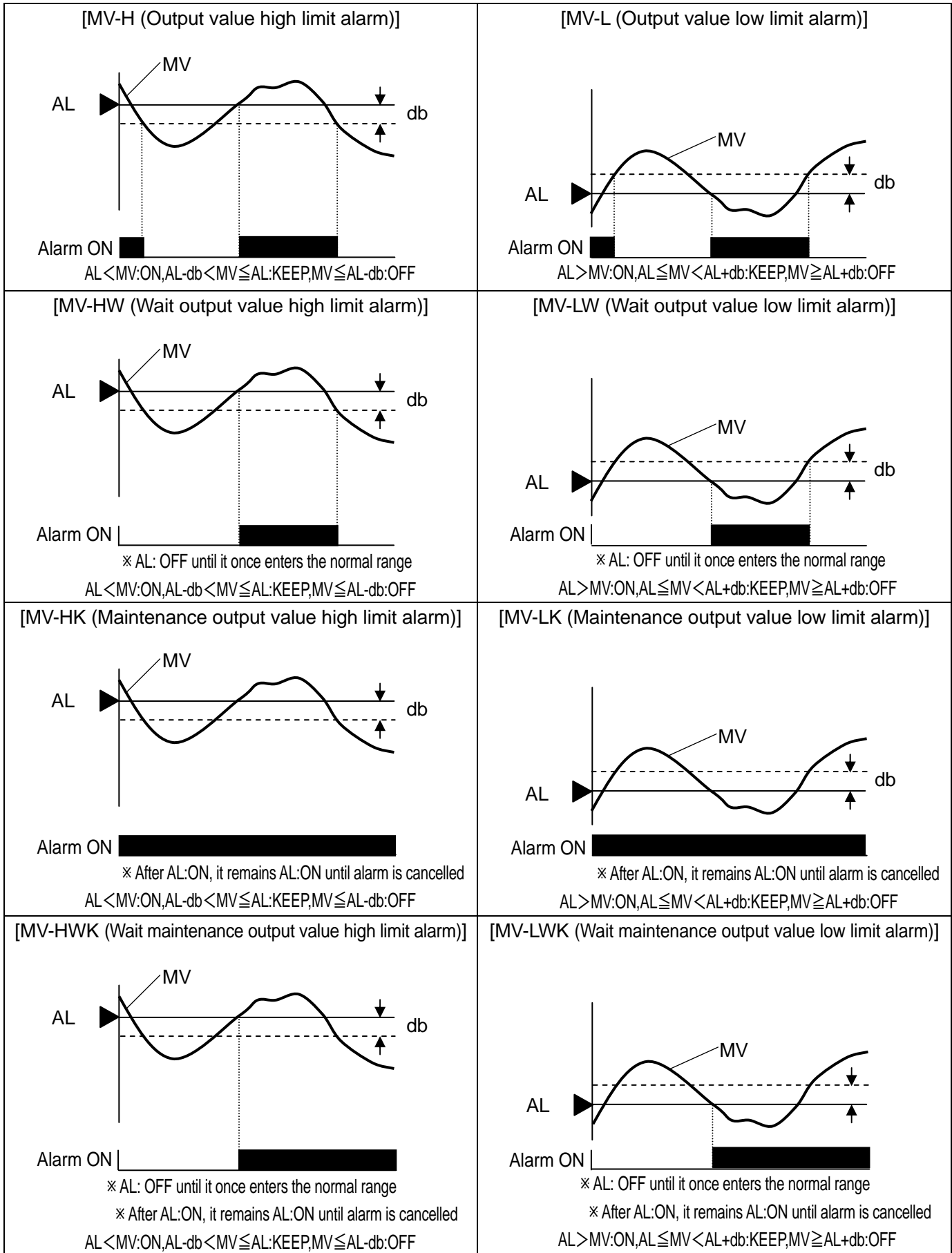

[CT (Heater snapping wire alarm)]

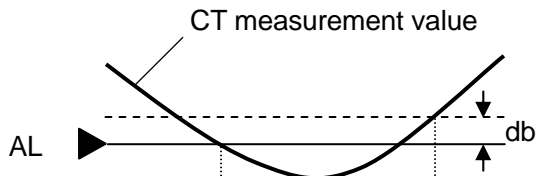

Alarm ON | 
 $AL > CT: ON, AL \leq CT < AL + db: KEEP, CT \geq AL + db: OFF$

- ① Only the specification with heater snapping wire alarm can be selected.
- ② After starting the initial CT value display becomes ' - - - A'. At that time alarm judgment is performed.
- ③ When the pulse value is being switched OFF, the last display value when it was ON is displayed.
- ④ As this alarm considers the delay in flow in current of the heater current after approximately 300mS onwards from the time when the output of the controller was switched ON, the heater current is measured and alarm is judged. Accordingly if output ON is less than 300mS, alarm judgment is not done.
- ⑤ When both outputs are pulse type, alarm is judged by output 1.

[LOOP (Control loop abnormal alarm)]

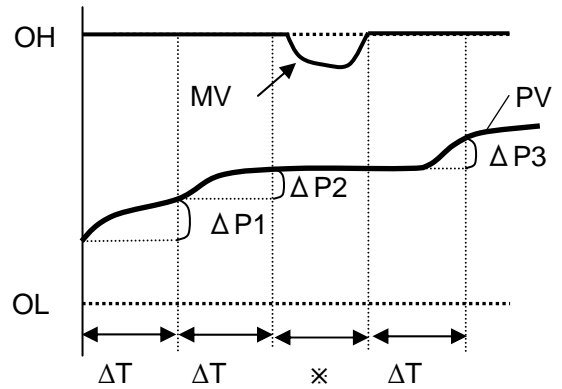

OH : High limit value of output limiter
 OL : Low limit value of output limiter
 ΔT : Judgment time

- ① Only output 1 specifications can be selected.
- ② Alarm judgment condition is as follows.
 - MV=OH (High limit value of output limiter)
 - MV=OL (Low limit value of output limiter)
 - When $OL < MV < OH$, alarm judgment is not done (× Section)
- ③ Alarm judgment value is as follows.
 - Alarm OFF : $|\Delta P_n| > |\text{Setting value}|$
 - Alarm ON : $|\Delta P_n| \leq |\text{Setting value}|$
 - Alarm judgment is done even if PV is ascending or descending.

[TIMER]

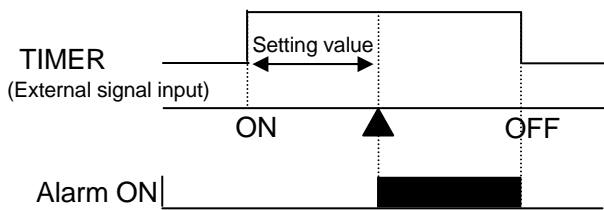

- ① Only specifications with external signal input can be selected.
- ② Allotment of timer and external signal input is as follows.
 - AL1:TIMER1
 - AL2:TIMER2
 - AL3:TIMER3
 - AL4:TIMER4
- ③ Time unit of alarm setting value is s (second).

10-4. Execution number and 8 parameters

This controller can set the important parameters related to control in a set of 8, including SV also. This set of 8 is registered as execution numbers 1 to 8 and just by selecting that execution number operation can be executed immediately by a totally different parameter.

In parameter in which 8 types of settings are possible, are as follows.

- SV 8 types : See mode 2.
- PID 8 types : See mode 3.
- Alarm 1 and alarm 2 8 types : See mode 3.
- Alarm 3 and alarm 4 8 types : See mode 3.
- Output limiter 8 types : See mode 4.
- Output change quantity delimiter 8 types : See mode 4.
- Sensor correction 8 types : See mode 5.
- Output preset 8 types : See mode 4.
- Remote shift 8 types : See mode 2.

Then parameters numbers 1 to 8 mentioned above correspond to execution numbers 1 to 8.

Execution number is selected by external signal input (only specifications with external signal input) or 'select execution number' of mode 1.

10-5. Auto tuning

Auto tuning (AT) is a function that automatically calculates PID constant.

Auto tuning has the following four types from AT1 to AT4.

① AT1

- It is an auto tuning for output 1.
- Execution can be done in RUN status (Excluding manual output operation).
- Execute auto tuning by SV that is being executed.
- PID calculated using AT1 is registered in PID of the PID number that is executing.

② AT2

- It is an auto tuning for output 1.
- Execution can be done in RUN status (Excluding manual output operation).
- Set 8 types of SV for AT2 beforehand and calculate 8 types of PID accordingly.
- PID calculated using AT2 is registered in respective PID numbers from 1 to 8. 8 types can separately set ON/OFF of AT and AT execution of arbitrary number only can also be done.

③ AT3

- It is an auto tuning for output 1.
- Execution can be done in READY status (Excluding manual output operation).
- Set 8 types of SV for AT3 beforehand and calculate 8 types of PID accordingly.
- PID calculated using AT3 is registered in respective PID numbers from 9-1 to 9-8. 8 types can separately set ON/OFF of AT and AT execution of arbitrary number only can also be done.

④ AT4

- It is an auto tuning for output 2.
- Execution can be done in RUN status (Excluding manual output operation).
- Execute auto tuning by SV that is being executed.
- PID calculated using AT4 is registered in output 2 PID.

In case of output 2 specifications, MV (output value) on output 2 side during non executable AT is continued control.

Sometimes even on starting the auto tuning operation normally, PID is not requested. Conditions when it is not requested are as follows. In that case PID constants are not changed and the original PID constants remain.

- When response is delayed too much, when it does not end even after around six hours of auto tuning operation.
- When the value of P calculated by auto tuning is less than 0.1% or more than 1000%.
- When the value of I calculated by auto tuning is less than 1 second.
- When the value of D calculated by auto tuning is less than 1 second.

10-6. PID control

PID is the most generic control algorithm that consists of three operations namely P (Proportion), I (Integration) and D (Differentiation).

① P operation

- It is the basic operation of PID control. It largely affects the responsiveness and the stability. Offset occurs only in proportion operation.
- If P is increased, the amplitude of PV (measurement value) becomes less and the stability improves however the responsiveness deteriorates.
- By setting $P=0\%$ two-position control action takes place.





② I operation

- Offset due to P operation can be eliminated however as the phase is delayed stability deteriorates.
- If I is reduced (integral operation is strengthened), responsiveness improves, over shoot increases.
- Setting value '0' is equivalent to ∞ (infinity).

③ D operation

- It compensates the time that is wasted and delay in phase due to delayed elements. However as gain in high frequency area increases, there is a limit for the strength.
- If D is increased, responsiveness increases for a large deviation, however for quick periodic deviations stability deteriorates.
- '0' of the settings value is equivalent to OFF.
- The setting value of D, is $1/6^{\text{th}}$ to $1/4^{\text{th}}$ the setting value of I and it is generic.

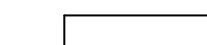
Collectively the PID operation is as follows.

	P (Proportion) operation	I (Integration) operation	D (Differentiation) operation
Input			
Output			

The controller has 2 types of PID control algorithms installed, either of it can be selected.

① POSITION

- Position type PID system.
- Comparatively, response is valid for control target.

② VELOCITY

- Speed type PID system.
- Comparatively, response is valid for quick control target.

For theory and details of PID control see its special literature.

10-7. Automatic PID switching system

For execution number system, automatic PID switching system makes maximum 8 divisions of SV section in which measurement scope is considered as maximum range and registers a PID in each of that SV section beforehand. As a result this function operates by using the PID that is registered in each of those SV sections when any of the SV is executed.

Hence once the PID numbers from 9-1 to 9-8 are set, for SV section and automatic PID switching system, even though the SV is changed, there is no trouble of changing the PID accordingly.

Automatic PID switching system is a function of PID for output 1 only. There is only one type of PID for output 2.

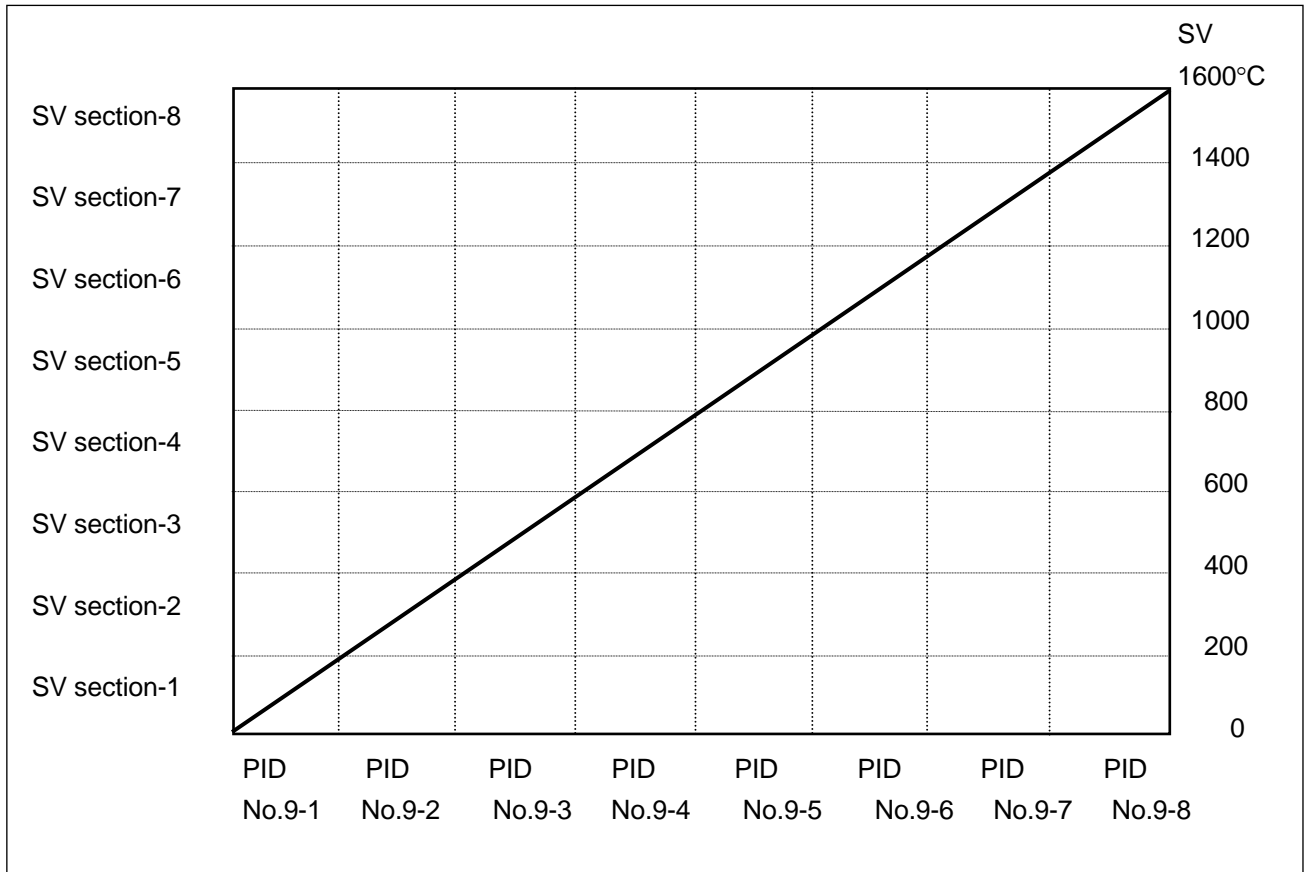

Refer to the above when reading the explanation of setting method.

① Setting SV section

- Confirm the setting range and SV range and decide in how many parts is the SV section to be divided.
- Set SV section in 'SV section for automatic PID' of mode 3.

※ In the above example, measurement scope is 0 to 1600°C, and for a span of 1600°C eight sections each of 200°C are done and SV section is set.

② Setting PID

- In 'PID 16 types' of mode 3, PID numbers from 9-1 to 9-8 according to the SV sections, are set.

※ PID can be requested from auto tuning also. Auto tuning that requests PID numbers from 9-1 to 9-8 is AT3.

③ Selecting PID system

- Select 'No.9' in 'Select PIDNo. system' of mode 1.

10-8. Actuator adjustment of ON-OFF servo type





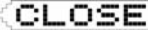
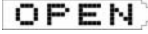

If the output format is ON-OFF servo type, the controller and the actuator (motor etc.) should be adjusted. Do the adjustment basically by auto adjustment. Fine adjustment can be done manually also, however if you are using it for the first time, use the automatic adjustment first and then the manual fine adjustment. When auto adjustment is not performed, output value of output display screen and feedback value have a margin of error.

1. Auto adjustment

- ① Initializing the setting value
 - Before the adjustment, consider the setting value of 'FB dead band' of mode 4 as the initial value.
 - For initial value, the dead band becomes 1.0%.
 - Other than that for output in the range of 0-100%, confirm each parameter.
- ② Zero span adjustment
 - Select 'START' in 'FB tuning' of mode 4, click  key and start FB tuning, and then adjusted data of feedback which is displayed at output display screen is initialized.
 - The actuator automatically runs on  side and  side and calculates the zero span value automatically.
 - When FB tuning is completed, return to 'END'.
 - The automatically calculated zero span value is automatically registered in 'FB zero span' of mode 4 hence confirm it.
- ③ Dead band adjustment (Gain adjustment)
 - See ⑤ of "Manual adjustment".

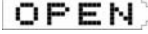
If the movement of actuator is delayed too much, auto calculation by 'FB tuning' is not possible. In that case after a fixed period return to 'END' and zero span value is not registered.

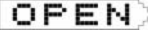
2. Manual adjustment

- ① Initializing the setting value
 - Before the adjustment, return the setting value of 'FB dead band' and 'FB zero span' of mode 4 to initial value.
 - Initial values are zero is 0.0%, span is 100.0% and dead band is 1.0%.
 - Other than that for output in the range of 0-100%, confirm each parameter.
- ② Zero adjustment
 - Perform manual output operation (manual output) and set the output value to 0.0%.
 - Actuator scales out on  side.
 - Increase the output value by 0.1% every time and request an output value that erases  display.
- ③ Span adjustment
 - Similarly the output value is set to 100.0%.
 - Actuator scales out on  side.
 - Decrease the output value by 0.1% every time and request an output value that erases  display.
- ④ Registering zero span value
 - Set the output value requested in ① and ②, in 'FB zero span' of mode 4 respectively.
- ⑤ Dead band adjustment (Gain adjustment)
 - Successively, similarly set the output value to 50.0%.
 - Increase the setting value a little every time in 'FB dead zone' of mode 4 and request a setting value that erases both the displays of  and  of the operation screen.
 - Perform a trial operation, increase the setting value little by little until the range where there is no error in controllability and set the greatest value as the settings value of final 'FB dead band'.

10-9. Output 2

Output 2 system of the controller is made for heating and cooling and has two types of systems PID system and SPRIT system.

Understand each system properly and then select the appropriate one.

1. PID system

- It is a system for setting PID of output 2 and gap between output 1 and output 2.
- Usually, consider output 1 as heating operation and set 'direct/reverse controlling operation' of mode 4 as 'REVERSE' and consider output 2 as cooling operation and set controlling operation as 'DIRECT'.
- Gap is as shown in the figure below. It is called the gap between SV and 0% of output 2 (For proportion band).
- When both output 1 and output 2 are $PV=SV$, if you want output to be 50% (When I operation and D operation are not included), it can be done by requesting a gap $G (\%) = -P/2$ (P: Proportion band of output 2, output 2 is direct operation).

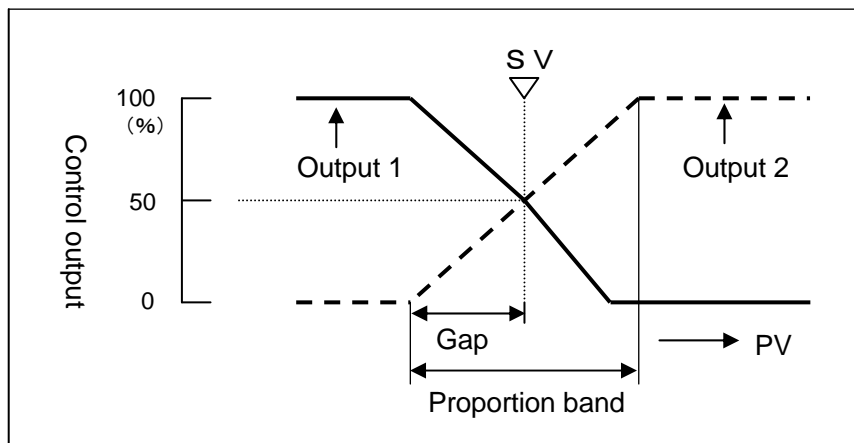

2. SPRIT system

- In matching box calculation system, PID calculation result of output 1 is considered as base and the operation shown in the following figure takes place.
- Setting range is 0-60% for DIRECT and 40-100% for REVERSE.
- When output 1 is set 'REVERSE' in setting of 'direct/reverse controlling operation' of mode 4, output 2 performs 'REVERSE' operation. When output 1 is set 'DIRECT', output 2 performs 'REVERSE'.

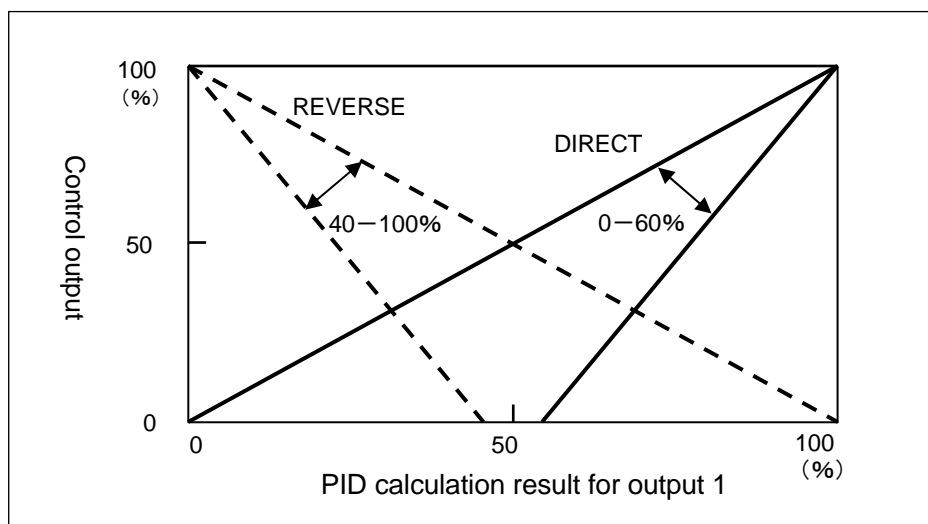

10-11. Transmission signal output

It is a function that selects one type from PV (measurement value), SV (measurement value), MV1 (Output value 1), MV2 (Output value 2), MFB (feedback value), RSV (Remote SV) and outputs using analog signal. Output 2 specifications of transmission signal output depending on the format are also available.

For example it is used in applications like, selecting a PV transmission and connecting that analog signal to the recorder and recording the PV of this controller in the recorder. Specifications of analog signal are specified in a format.

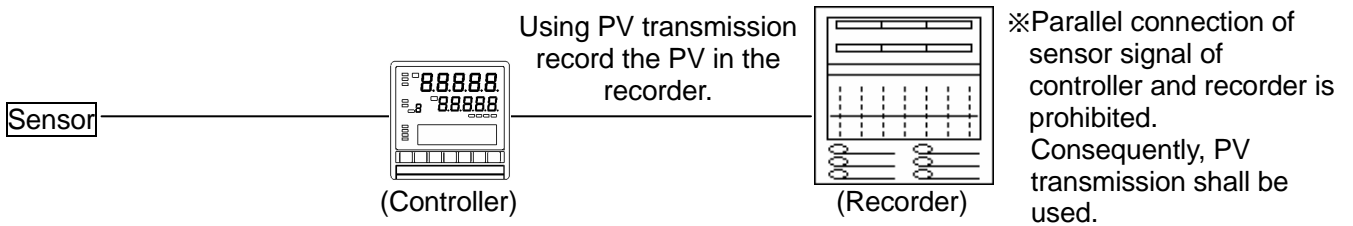

The following occurs when transmission signal output with 4-20mA is specified and measurement range K1 and in a range of 0-1200°C transmits PV.

·Set 'PV' in 'transmission type' of mode 6 and '0-1200' in 'transmission scale'.

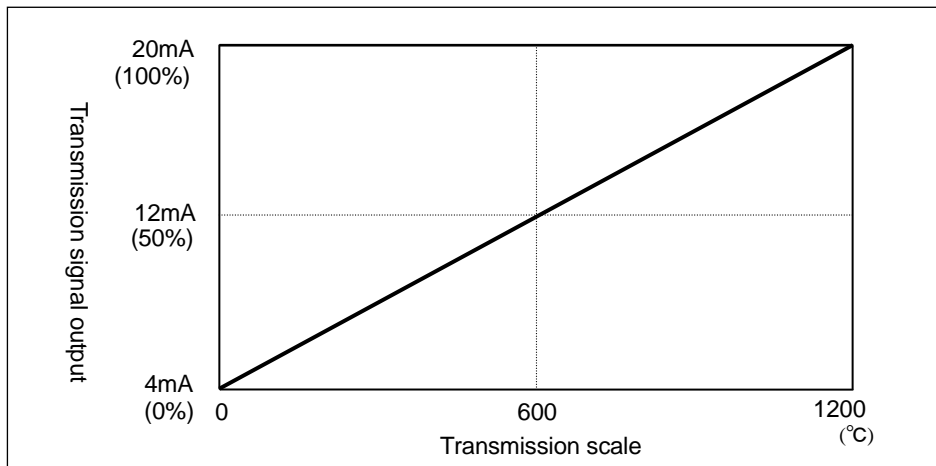

10-10. Remote signal input

A function that enables the SV setting by using analog signal from outside.

For example by connecting to controller the SV transmission of program controller, you can use it as simple program controller. Specifications of analog signal are specified in a format.

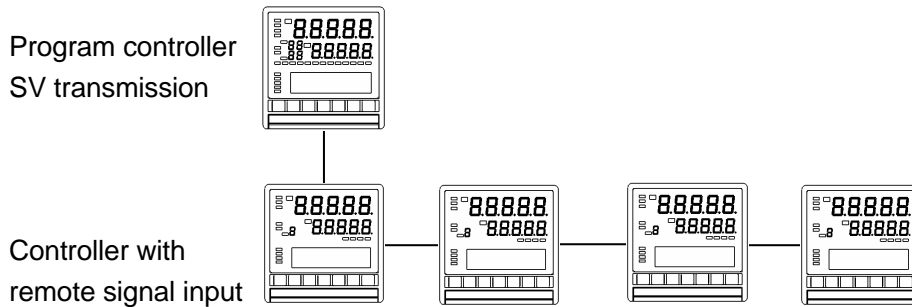

The following occurs when remote signal input with 4-20mA specified and in a range of 0-1200°C performs remote SV.

- Set '0 to 1200' in 'remote scale' of mode 2.
- Select 'remote' in external signal input (R/L) and 'REMOTE' in 'remote/local switching' of mode 1.

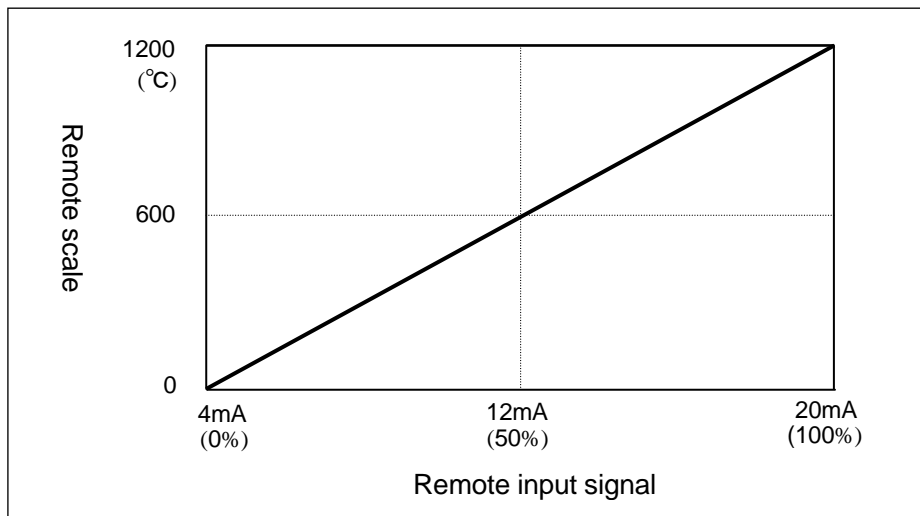

- Set 'remote shift 8 types', 'remote filter', 'tracking existence' of mode 2 to as per the requirement.

In case of specifications with remote signal input, it can be used as secondary regulator of cascade control loop. Calculation block of cascade control is as follows.

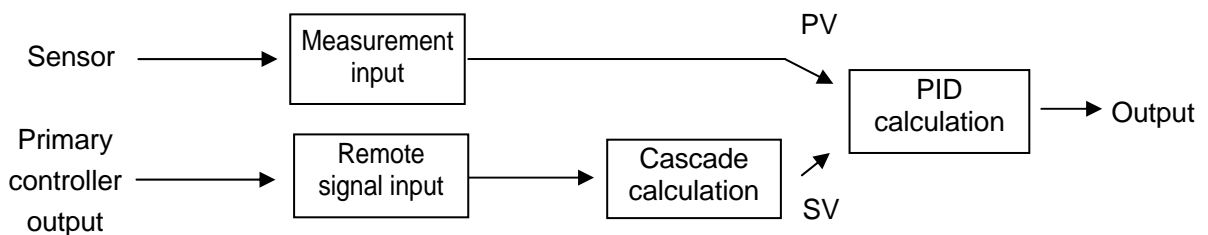

Get the ratio r and bias b by referring to the following diagram.

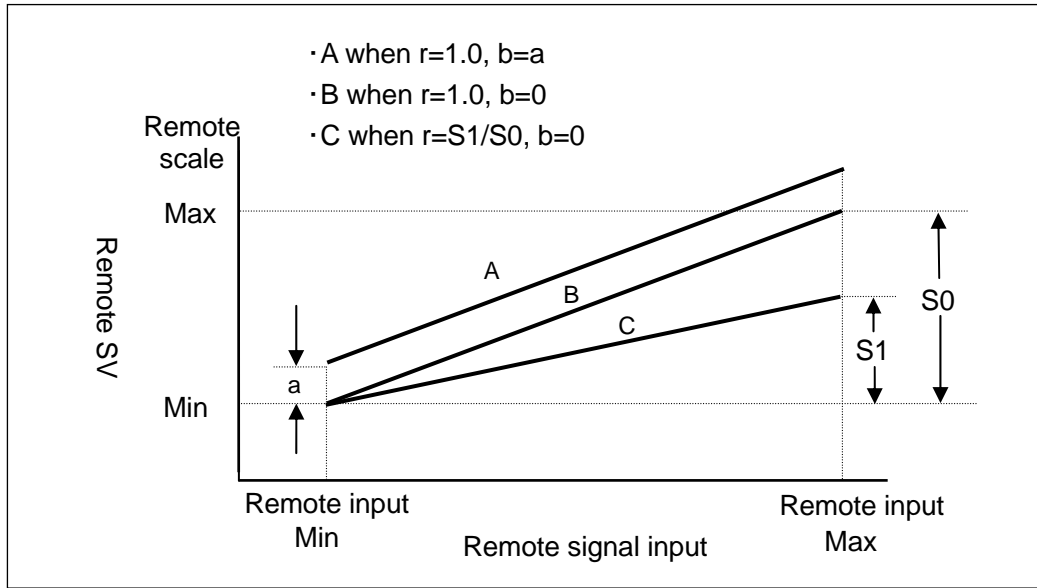



Cascade control always contains an experimental factor and requires a lot of control theory knowledge. Controller has a function that can set cascade constant, however cascade control cannot be assured when using this function.

10-12. External signal input

In case of specifications with external drive input, this controller can have specific functions by using conductive signal (ON/OFF) of external no contact signal (relay, switch, open-collector signal etc.). In 'External signal allotment' of mode 11, the external signal input function and terminal number is allotted and used. When external signal is allotted at 'External signal allotment' and external signal input is switched, key operation or switching by communications may be invalidated.

In remote signal input and communications interface, in order to switch between remote SV and local SV an exclusive external signal input (R/L switching) is provided. This terminal is exclusively for R/L switching and you cannot use it for changes in the other functions of external signal input. R/L switching cannot also be allotted in external signal input.

Function name	Description																																													
1. SV1 SV2 SV4 SV8	<ul style="list-style-type: none"> It is a function for selecting execution number. Selection of execution number is based on control signal from BCD code. Control the fixed external signal input using continuous signal. Depending on the execution number to be selected, external signal input with ○ mark is conducted (ON) as follows. After conduction (ON) execution number is selected in around 0.5 seconds or more. <table border="1"> <thead> <tr> <th></th> <th>Execution No.8</th> <th>Execution No.7</th> <th>Execution No.6</th> <th>Execution No.5</th> <th>Execution No.4</th> <th>Execution No.3</th> <th>Execution No.2</th> <th>Execution No.1</th> </tr> </thead> <tbody> <tr> <td>SV8</td> <td>○</td> <td>×</td> <td>×</td> <td>×</td> <td>×</td> <td>×</td> <td>×</td> <td>×</td> </tr> <tr> <td>SV4</td> <td>×</td> <td>○</td> <td>○</td> <td>○</td> <td>○</td> <td>×</td> <td>×</td> <td>×</td> </tr> <tr> <td>SV2</td> <td>×</td> <td>○</td> <td>○</td> <td>×</td> <td>×</td> <td>○</td> <td>○</td> <td>×</td> </tr> <tr> <td>SV1</td> <td>×</td> <td>○</td> <td>×</td> <td>○</td> <td>×</td> <td>○</td> <td>×</td> <td>○</td> </tr> </tbody> </table> <ul style="list-style-type: none"> When selecting BCD code other than that mentioned above (Execution numbers 1 to 8) the execution number that was being executed before selection remains. When selecting the execution number from 'Select execution number' of mode 1, select BCD code other than that mentioned above for external signal input (execution number 1 to 8). Generally consider all the four external input signals as non conductive (BCD code:0). Then select the execution number from 'Select execution number' of mode 1. For example if only the execution numbers from 1 to 4 need to be selected, only three external signal inputs that is SV1, SV2 and SV4 can also be allotted. 		Execution No.8	Execution No.7	Execution No.6	Execution No.5	Execution No.4	Execution No.3	Execution No.2	Execution No.1	SV8	○	×	×	×	×	×	×	×	SV4	×	○	○	○	○	×	×	×	SV2	×	○	○	×	×	○	○	×	SV1	×	○	×	○	×	○	×	○
	Execution No.8	Execution No.7	Execution No.6	Execution No.5	Execution No.4	Execution No.3	Execution No.2	Execution No.1																																						
SV8	○	×	×	×	×	×	×	×																																						
SV4	×	○	○	○	○	×	×	×																																						
SV2	×	○	○	×	×	○	○	×																																						
SV1	×	○	×	○	×	○	×	○																																						
2. READY/RUN	<ul style="list-style-type: none"> It is a function for switching between READY status and RUN status. Fixed external signal input is controlled by continuous signal. In around 0.5 seconds or more after conduction (ON), it is in READY status and in around 0.5 seconds or more after non-conduction (OFF), it is in RUN status. When switching between READY/RUN using external signal input, 'Switch RUN/READY' of mode 1 selects 'RUN' and thus switching by external signal input is done. 																																													

Function name	Description
3. MAN1/AUTO1	<ul style="list-style-type: none"> · It is a function for switching between manual output operation (manual output) and automatic output operation (automatic output) of output 1. · Fixed external signal input is controlled by continuous signal. In around 0.5 seconds or more after conduction (ON), it is manual output operation and in around 0.5 seconds or more after non-conduction (OFF), it is automatic output operation. · When switching between MAN/AUTO is done using external signal input, the key operation on the operation screen selects 'AUTO' and then switching is done by external signal input. · At the time of manual output switching, 'e' is displayed on the left side of 'OUT' on the operation screen. 
4. MAN2/AUTO2	<ul style="list-style-type: none"> · It is a function for switching between manual output operation (Manual output) and automatic output operation (automatic output) of output 2 and only output 2 specifications can be selected. · Fixed external signal input is controlled by continuous signal. In around 0.5 seconds or more after conduction (ON), it is manual output operation and in around 0.5 seconds or more after non-conduction (OFF), it is automatic output operation. · When switching between MAN/AUTO is done using external signal input, the key operation on the operation screen selects 'AUTO' and then switching is done by external signal input. · At the time of manual output switching, 'e' is displayed on the left side of 'OUT' on the operation screen. 
5. PRESET/AUTO	<ul style="list-style-type: none"> · It is a function for switching between output preset operation (Preset manual output) and automatic output operation (Auto output). · Fixed external signal input is controlled by continuous signal. In around 0.5 seconds or more after conduction (ON), it is output preset operation and in around 0.5 seconds or more after non-conduction (OFF), it is automatic output operation. · When switch from automatic output operation to output preset operation, MV (output value) become setting value according to changing rate which is set at No.9 of output variation limiter. When switch from output preset operation to automatic output operation, it will be automatic output according to balancelless bumpless operation. · In case of output preset operation, output value becomes the setting value of 'preset manual' of mode 4, alarm operation is executed and auto tuning cannot be executed. · 'p' is displayed on the left side of 'OUT' of the operation screen at the time of switching the preset manual output. 

Function name	Description
6. REMOTE R/L	<ul style="list-style-type: none"> · It is a switching function of remote SV and local SV of remote signal input and this function is always added (R/L exclusive terminal exclusive function) in remote signal input specifications. This function cannot be allotted in general external signal input. · Fixed external signal input is controlled by continuous signal. In around 0.5 seconds or more after conduction (ON), it is remote SV and in around 0.5 seconds or more after non-conduction (OFF), it is local SV. · When switching between REMOTE/LOCAL using external signal input, 'Remote/Local switching' of mode 1 selects 'REMOTE' and switching is done by external signal input (R/L).
7. COM R/L	<ul style="list-style-type: none"> · It is the remote SV and local SV of communication remote function and this function is always added (R/L exclusive terminal exclusive function) in communication interface specifications. This function cannot be allotted in general external signal input. · Fixed external signal input is controlled by continuous signal. In around 0.5 seconds or more after conduction (ON), it is remote SV and in around 0.5 seconds or more after non-conduction (OFF), it is local SV. · When switching between REMOTE/LOCAL using external signal input, 'Remote/Local switching' of mode 1 selects 'REMOTE' and switching is done by external signal input (R/L). · When you want to use remote SV (analog remote) by remote signal input and remote SV (digital remote) by communication remote function by switching, see to it that the switching signals of remote operation due to two external signal inputs are not overlapping (simultaneous conduction). If it overlaps then remote SV (analog SV) by remote signal input is given priority.
8. ALARM RESET	<ul style="list-style-type: none"> · It is a function that resets (cancels) alarm output. · Fixed external signal input is controlled by momentary signal. In around 0.5 seconds or more after conduction (ON), it is reset. After reset as it returns to normal status, immediately change to non conduction (OFF).
9. PV HOLD	<ul style="list-style-type: none"> · It is the PV hold function. · Fixed external signal input is controlled by continuous signal. In around 0.5 seconds or more after conduction (ON), status is 'hold'. · When performing 'hold' using external signal 'PV hold' of mode 1 selects 'NON' and switching is done by external signal input. · Hold status is the value of PV just before the settings and PV is fixed and control action continues with that PV.
10. TIMER1 TIMER2 TIMER3 TIMER4	<ul style="list-style-type: none"> · It is a function for switching between timer start/reset. · Fixed external signal input is controlled by continuous signal. In around 0.5 seconds or more after conduction (ON), the status of timer is start and in around 0.5 seconds or more after non-conduction (OFF), it is reset. · TIMER1, TIMER2, TIMER3 and TIMER4 are respectively allotted to AL1, AL2, AL3 and AL4.

Function name	Description
11. SLOPE HOLD	<ul style="list-style-type: none"> · It is a function for holding (fixed) during the slope operation, in SV slope operation by SV change rate. · Fixed external signal input is controlled by continuous signal. In around 0.5 seconds or more after conduction (ON), the status of slope operation is hold and in around 0.5 seconds or more after non-conduction (OFF), the slope operation restarts. · In hold status, in 'value of SV just before setting' SV is fixed and control action continues with that SV.
12. SLOPE RESET	<ul style="list-style-type: none"> · It is a function that cancels the slope operation, in SV slope operation depending on SV change rate. · Fixed external signal input is controlled by momentary signal. In around 0.5 seconds or more after conduction (ON), the status is slope operation reset. After reset, in order to return to normal status, change to non- conduction (OFF) right away. If the status is kept as conduction (ON) without returning, the status that is reset continues. · When reset, SV slope operation stops, momentarily SV switches to final SV after it exits the slope and control operation continues with that SV. · In case of hold status of SV operation, reset is given priority and resetting can be done.

*' No setting condition '----' is displayed when shipped form factory. If set any function once, not setting condition is not displayed. Allocation setting is not initialized (no setting condition), even if contents of settings are initialized.

10-13. Communications interface

The controller is provided with various communications functions and they are as follows.

10-13-1. Engineering port

It is a communications function provided in all the products. Engineering port exists on the right side on the front after opening the lower cover of the front part. Communications with the PC can be done by connecting an exclusive engineering cable (sold separately).

Specifications of communications by using the engineering port is as follows.

- Communications protocol : MODBUS-RTU
- Communications speed : 9600bps
- Communications character : bit length 8/parity NON/stop bit 1

10-13-2. Specifications with communication

Usually when doing communications, select specifications with communications. Type of communications can be selected from amongst RS232C, RS422A and RS485. Only for RS232C and RS485 second port communications can also be added.

Communications enables the setting of parameters (Data Write) and data reading (Data Read) by connecting to PC and remote operation for which PC is used and data management can be done. There is one more functionality namely communications transmission (digital transmission) function/communications remote (digital remote) function. This function enables realization of a remote operation without any error by sending the SV transmission by using communications and receiving it as remote SV by using communications. Remote operation due to remote signal input is called Analog Remote and on the other hand remote operation due to communications remote is called Digital Remote.

The following diagram is a model example of remote operation by communications transmission/communication remote function while selecting specifications with 2 port communications and performing high order communications with the PC.

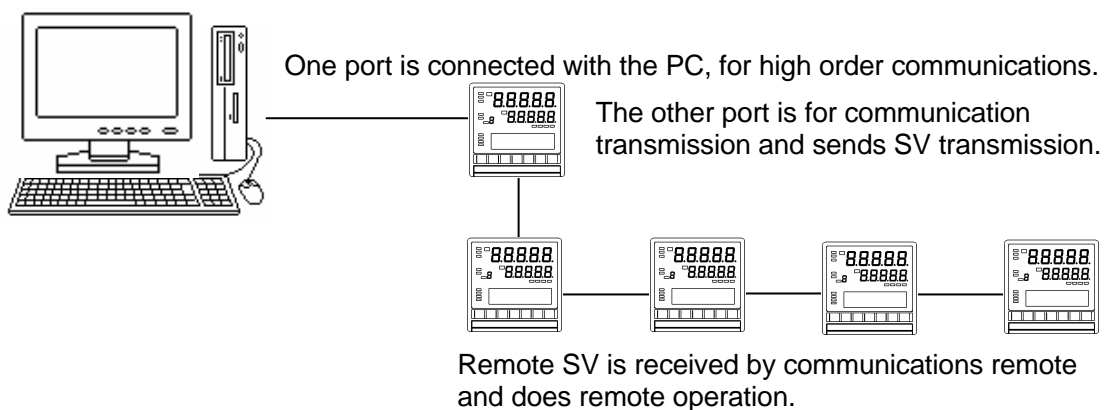

In case of communications 2 port specifications, communications remote function gets selected with COM1, and COM2 on the settings screen however see to it that they do not overlap (Selecting communications remote function along with COM1, COM2). If they overlap, remote SV on COM 2 side is given priority.

10-14. Customer scale correction

In this controller a function for correcting the customer scale is provided in mode 12. High precision voltage current occurrence device, digital multi-meter, dial resistance device etc. is prepared and customer scale correction can be done.

10-14-1. Overview

This function can perform scale correction of the following input output functions.

- Measurement range.
- Output 1 (Output 1 is only current output or voltage output).
- Output 2 (Output 2 is only current output or voltage output).
- Remote signal input (With remote signal input only).
- High precision type transmission signal output (With transmission signal output only).
- General type transmission signal output (With transmission signal output only).
- CT input (With heater snapping wire alarm only).

10-14-2. Viewpoint of scale correction

Scale correction is done by internal operation process using the following expression [$Y=aX+b$] and two correction values namely zero correction (equivalent to b) and span correction (equivalent to a) are used.

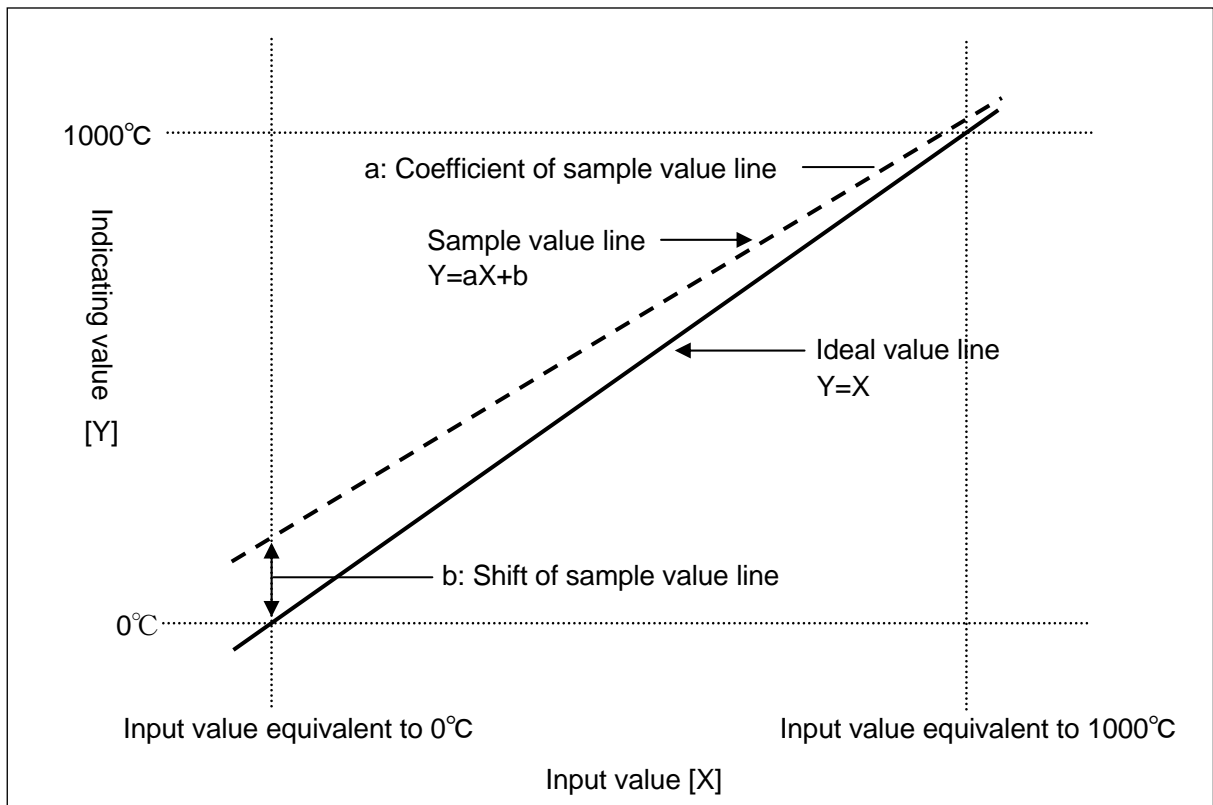

Ideal value line is a straight line when there is no measurement error. If 'input value equivalent to 0°C' is entered, 0°C is indicated whereas when 'input value equivalent to 1000°C' is entered, 1000°C is indicated. Thus according to the expression as there is no correction value, $Y=X$.

In case of sample value line, as compared to ideal value line, it shifts to + side by b units in the neighborhood of 0°C and the tilt of straight line lowers.

For example when 'input value equivalent to 0°C' is entered '+20°C' is indicated and when 'input value equivalent to 1000°C' is entered, 1005°C is indicated and so on.

Thus bias(b) equivalent to -20°C is added and multiplication by a coefficient that increases the tilting is done and thus ideal straight line is obtained. In other words, indicator shift can be lost.

Thus the expression is $Y=aX-b$.

10-14-3. Input related scale correction

Details about the procedure for input related (measurement range, remote signal, CT input) scale correction are as follows.

Scale correction of measurement range is done in the measurement range that is selected, hence if other measurement scale is selected after correction, indicator shifting occurs. This is because even when any measurement range is selected, the scale correction function operates with the same scale correction value. After the scale correction if measurement range is changed, perform scale correction again.

1. Preparations related to measurement device

Input to be corrected	Required measurement device and instruments
Measurement range	<ul style="list-style-type: none"> ① High precision voltage current occurrence device <ul style="list-style-type: none"> × Required for thermocouple, DC voltage, DC current correction. · Accuracy: Less than $\pm 0.05\%$. ② Digital multi-meter <ul style="list-style-type: none"> × Required for thermocouple, DC voltage, DC current correction. · Accuracy: Less than $\pm 0.05\%$. · If the accuracy of the voltage current occurrence device of clause ① is not good, confirm the voltage value (current value) using digital multi-meter also. ③ Dial resistance <ul style="list-style-type: none"> × Required in correction of resistance thermometer. · Accuracy: Less than $\pm 0.05\%$. ④ Thermocouple <ul style="list-style-type: none"> × Required in correction of thermocouple. · JIS:0.4 level. ⑤ Freezing point expression reference junction <ul style="list-style-type: none"> × Required in correction of thermocouple. · Accuracy: Less than $\pm 0.1^\circ\text{C}$. · Freezing point device that uses triple point of water.
Remote signal input	<ul style="list-style-type: none"> ① High precision voltage current occurrence device <ul style="list-style-type: none"> · Accuracy: Less than $\pm 0.05\%$. ② Digital multi-meter <ul style="list-style-type: none"> · Accuracy: Less than $\pm 0.05\%$.
CT input (Heater snapping wire alarm)	<ul style="list-style-type: none"> ① AC current occurrence device <ul style="list-style-type: none"> · Accuracy: Less than $\pm 0.2\%$.



Warning

To avoid serious accidents always cut off the power supply and then do the wiring.

2. Wiring

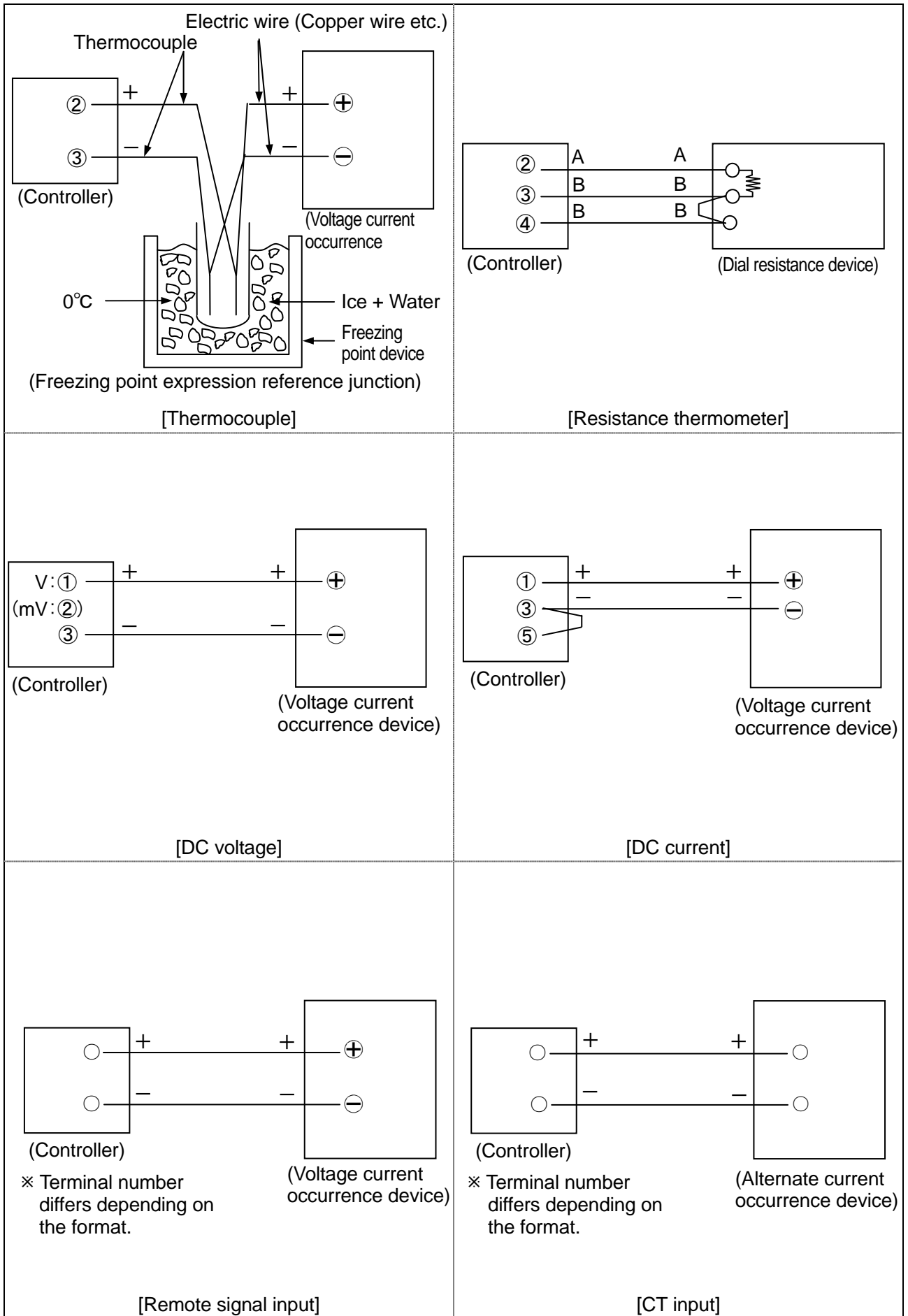

3. Scale correction

① Preparation and conduction

- By making operation condition of the controller as 'standard operation condition' the controller is stabilized.
- After confirming the wiring, it is stabilized by making relation of the controller and the measurement device stable.

② Indicator check before scale correction

- Select the measurement range that is to be actually used, refer to the following and perform indicator check (3 places) before scale correction.
- In case of thermocouple refer to thermo-electromotive table and in case of resistance thermometer refer to resistance value table and confirm the input values.

	Minimum value: □□□°C (Input value: □□□mV)	Medium value: □□□°C (Input value: □□□mV)	Maximum value: □□□°C (Input value: □□□mV)
Indicator check before correction			
Indicator check after correction			

③ Setting the zero correction value

- Enter the minimum value of measurement range.
- Compare the minimum value with the ideal value, if it is positive, set a negative zero correction value and if it is negative, set a positive zero correction value.
- By referring to the PV (measurement value), set the zero correction value such that it matches the ideal value.

④ Setting the span correction value

- Enter the maximum value of measurement range.
- If maximum value is positive as compared to ideal value, set the span correction value less than 1.0 and if the value is negative, set the span correction value as 1.0 or more.
- By referring to the PV (measurement value), set the span correction value such that it matches the ideal value.

⑤ Readjustment

- Repeat the adjustment mentioned in clauses ③ and ④ a number of times till the indicator value is in the permitted range.

⑥ Indicator check after correction

- Perform this check in the same way as the indicator check (3 places) before correction and confirm that there is no problem.

⑦ Precautions during scale correction of CT input

- CT input can measure heater current up to 100A by connecting external CT. Secondary current that is transformed by external CT is several ten mA, and those several ten mA are entered in this controller and heater current is measured indirectly. Hence in the scale correction of CT input, input the following standard current that is fixed (decided).

	Minimum value: 10A (Input value: 12.4mA AC)	Medium value: 50A (Input value: 68.2mA AC)	Maximum value: 100A (Input value: 124.0mA AC)
Indicator check before correction			
Indicator check after correction			

- Unit of standard current is mA. See to it that excessive current is not applied.
- Setting procedure of correction value is same as ③, ④, ⑤. However in order to display the CT measurement value, set 'ON' in 'CT screen existence' of mode 1 and make the manual output operation as 100% and it is necessary to set the condition that enables the display of CT measurement value in the operation screen.



Precautions

- ① If power supply that is out of rating range is connected, the product may get out of order, performance may deteriorate or it may malfunction.
- ② If excess voltage or excess current is applied to input output terminal of the controller, the product may get out of order, performance may deteriorate or it may malfunction.

10-14-4. Output related scale correction

Detailed procedure of output related (Current output/voltage output, transmission signal output) scale correction is as follows.

1. Preparation of measurement devices

Input to be corrected	Required measurement devices and tools
Current output/voltage output	① Digital multi-meter ·Accuracy: Less than $\pm 0.05\%$.
Transmission signal output	① Digital multi-meter ·Accuracy: Less than $\pm 0.05\%$.

2. Wiring

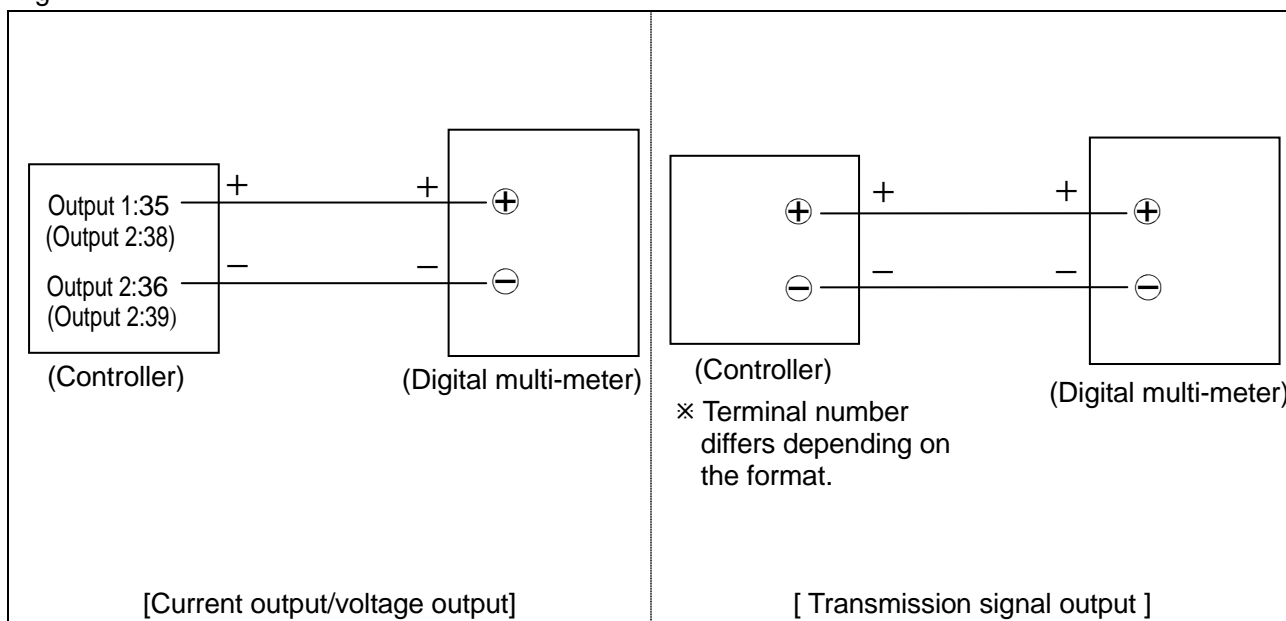

3. Scale correction

① Preparation and conduction

- By making operation environment of the controller as 'standard operation condition' the controller is stabilized.
- After confirming the wiring, it is stabilized by making relation of the controller and the measurement device stable.

② Indicator check before scale correction

- Refer to the following and perform the output check (3 places) before correction.

	Minimum value: □□mA (Input value: 0%)	Medium value: □□mA (Output value: 50%)	Maximum value: □□mA (Output value: 100%)
Indicator check before correction			
Indicator check after correction			

③ Setting zero correction value

- Output, output value 0%.
- If minimum value is positive as compared to ideal value, set negative value for zero correction and if maximum value is negative as compared to ideal value, set positive value for zero correction.
- By referring to the digital multi-meter, set the zero correction value such that it matches the ideal value.

④ Setting the span correction value

- Output, output value 100%.
- If maximum value is positive as compared to ideal value, set the span correction value less than 1.0 and if the value is negative, set the span correction value as 1.0 or more.
- By referring to the digital multi-meter, set the span correction value such that it matches the ideal value.

⑤ Readjustment

- Repeat the adjustment mentioned in clauses ③ and ④ a number of times till the indicator value is in the permitted range.

⑥ Indicator check after correction

- Perform this check in the same way as the indicator check (3 places) before correction and confirm that there is no problem.

⑦ Precautions during scale correction of current output/voltage output

- Current output and voltage output that exists in MV (output value) are adjusted such that they can be output in a range slightly broader than the factory shipping status. In other words for current output, at the time of 0% current is 4.0mA, adjusted to approximately 3.5 to 3.9mA and at the time of 100% current is 20.0mA adjusted to approximately 20.1 to 20.5mA. Normally in case of current output it is connected to the actuator like thyristor regulator, but in order to operate it as actuator in a certain range of 0-100% , eliminate the input error of those actuators. and make it such that it outputs in some broader range.
- Accordingly, we recommend that you adjust current output and voltage output which is MV (output value) can be adjusted to some low value for 0% and some high value for 100%. However adjust the transmission output exactly to the standard value without considering such things.

11. Engineering port

This function can connect with the PC from the front of the controller. Even if this function is not in the specifications with communication interface, it is provided as standard to all products.

An exclusive engineering cable is inserted in this port and connected to the PC.

Parameter setup software 'PASS' is available with our company. Various parameters can be easily set from the front of the controller by using this 'PASS' and engineering cable, and note PC.

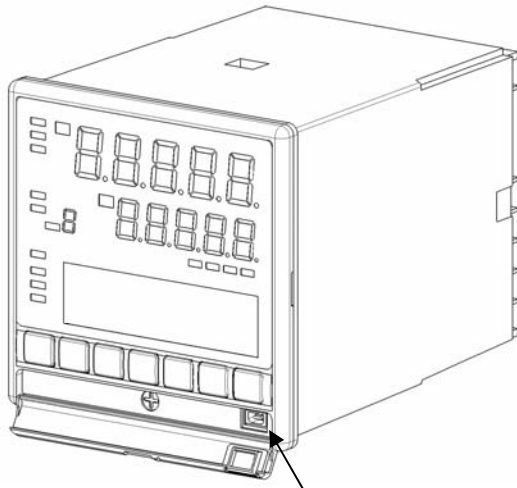

Engineering port

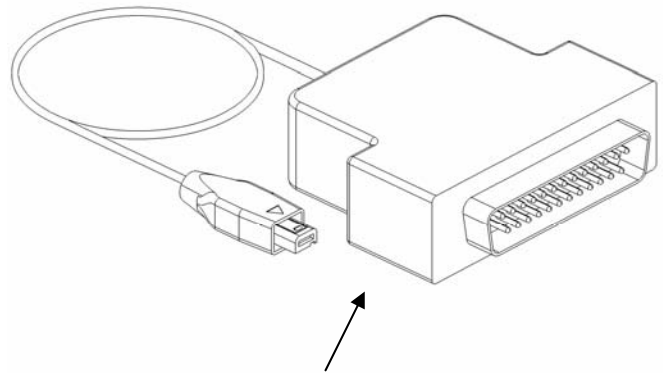

Engineering cable

Engineering port is used for temporary communication connection on that structure and is not for usual connection.

If you want to carry out the communication by usual connection, while purchasing specify specifications with communication interface and do a permanent connection from the back side.

 Precaution	Connecting and disconnecting of engineering cable to engineering port in this instrument should be done while applying power.
---	---

12. Trouble shooting

Condition	Items to be confirmed
1. There is an error in PV or PV is not stable	<ul style="list-style-type: none"> ▪ Confirm that there is no problem in the wiring with the sensor. ▪ For thermocouple confirm that wiring is done till the terminal screw by using thermocouple and compensation lead wire. ▪ Confirm that the terminal screws are tightened properly. ▪ Confirm that sensor signal is not connected in parallel with other instrument. ▪ Confirm that protective elements etc are connected to sensor signal and the impedance does not become high. ▪ Confirm that there is no problem in output specifications (impedance etc.) and output signal of sensor itself. ▪ Confirm that ground terminal is connected to good quality protective ground. ▪ Confirm that there is no noise. ▪ Confirm that there is no problem in the environment and atmosphere (surrounding temperature, wind etc.) ▪ Confirm that set contents of various parameters (Measurement range, sensor correction, customer scale calibration etc) are correct.
2. PV display becomes '-----'.	<ul style="list-style-type: none"> ▪ It indicates excessive input or higher limit burn out for measurement range. Confirm the sensor signal.
3. PV display becomes '------'.	<ul style="list-style-type: none"> ▪ It indicates very little input or lower limit burn out for measurement range. Confirm the sensor signal.
4. Control is not stable.	<ul style="list-style-type: none"> ▪ Confirm that there is no problem with the wiring of the actuator. ▪ Confirm that the terminal screw is tightened properly. ▪ Confirm that there is no noise. ▪ Confirm that the set contents of various parameters (PID, output limiter etc.) are correct. <p style="margin-left: 40px;">× Regarding controllability, it is necessary to do the design/adjustment not only in just the controller but in the entire system of the final product. If the controllability does not improve even on adjusting the set contents of various parameters (PID etc.) of the controller, consult the designer of this final product.</p>
5. 'ERR' of status display illuminates.	<ul style="list-style-type: none"> ▪ It indicates abnormality in taking the input. In addition to chances of abnormality in the internal circuit of the controller, it might be adversely affected by noise also, hence confirm that there is no noise.
6. Cause unclear however operation is strange	<ul style="list-style-type: none"> ▪ Confirm that the contents of various parameters are correct. ▪ Even then if the operation of the controller is strange, initialize the set contents. Do all the settings again and confirm that there is no problem in it.

Condition	Items to be confirmed
7. Lower display is not displayed normally, displayed strips.	<ul style="list-style-type: none"> ▪ Set the proper value of the [Display contrast] in mode11. 40 to 70% of range is suitable setting value. When setting the range of 80 to 100%, stripes appear in the LCD. The setting value is set the initial value (50%) in ordinary use.
8. Error message is displayed when setting the parameter	<ul style="list-style-type: none"> ▪ After confirming error message, change to the correct setting because of the setting which is not registered.
9. Error message is displayed when starting operations	<ul style="list-style-type: none"> ▪ After confirming error message, change to the correct setting because of the setting which is not started operation.

When problems are not improved after executing the above troubleshooting, contact the dealer or your local CHINO's sales agent.

 Warning	<p>When repair or modification of this instrument is needed, contact the dealer or your local CHINO's sales agent. Make sure that no persons other than service engineers approved by CHINO CORPORATION do not repair or modify this instrument by replacing parts.</p> <p>The data of settings may be deleted during repairing for unexpected trouble (power failure, earthquake, or other unexpected accident).</p> <p>Backup the data of settings before having the instrument repaired. We are not responsible for the lost or damaged data.</p>
--	--

13. Checking and maintenance

13-1. Checking

13-1-1. Checking according to the trial operation

Every time before starting the operation do a trial operation and confirm that the controller and the final product are normal.

13-1-2. Checking the accuracy

For the controller, depending on the requirement of the client periodical accuracy checking like measurement accuracy of PV (measurement value), accuracy of transmission signal etc. is necessary. Due to secular changes, these may slightly drift from accuracy, from the time when it was purchased.

By using the customer scale correction function that exists in mode 12, correction can also be done by the customer, however even our company does the accuracy check hence you can contact your dealer or nearest branch office of our company.

13-1-3. Overhaul

Since the controller is reliable, we recommend an overhaul after 2-3 years. For ordering overhaul contact your dealer or our company's nearest office.

13-2. Life component

Clear life component of the controller is as follows.

Please understand that secular changes and aging occurs in almost all the products.

Component name	Estimated life
1. Relay × Relay for control, relay for alarm.	Approximately one hundred thousand times
2. Electrolysis condenser × Condenser for smoothness of electric circuit.	Approximately 5 years (Surrounding temperature : 30°C, operation time : 12 hours/day)

13-3. Disposal



Precaution

- ① A small amount of hazardous substance below the specified level with RoHS directive is included in this controller.
- ② When disposing the controller always request a professional to do it, or dispose the controller in according to the garbage collection method of the each community.
- ③ Separate the box, plastic bags, and cushioning materials the controller is packaged in according to the garbage collection method of the each community, and please cooperate to recycle.

14. Explanation of terms

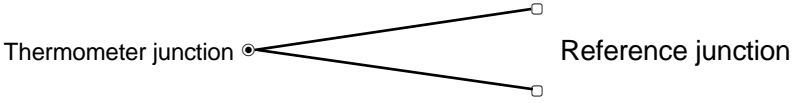
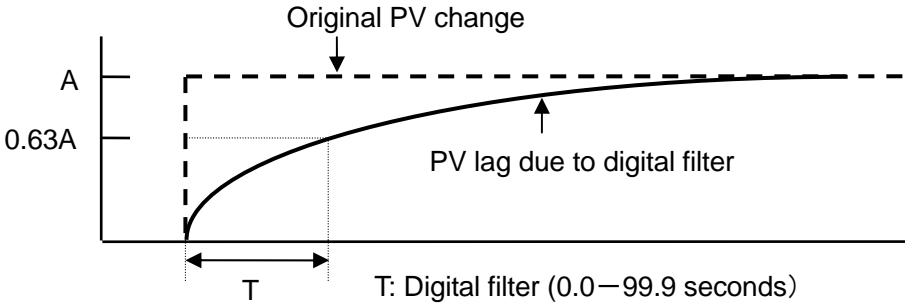
Term	Explanation
Unit	<p>Only for thermocouple or resistance thermometer select °C or K. Operation equation is as follows.</p> <ul style="list-style-type: none"> • °C = K - 273.15 • K = °C + 273.15
<p>RJ (Reference Junction)</p>	<p>Thermocouple has measurement junction (temperature measurement side) and reference junction (electromotive force generation side) and reference junction decides the standards of thermo-electromotive force table (with scale) at 0°C condition.</p>  <p>When connecting the thermocouple to terminal of the controller, usually the temperature of the terminal becomes same as the surrounding temperature and is not 0°C. As a result, unless that temperature is compensated correct temperature cannot be measured. That compensation that is done automatically in the product internally is called the compensation function 'RJ'.</p> <p>If thermocouple is selected in measurement range, this 'RJ' function becomes ON.</p>
Sensor correction	<p>It is a function that corrects (bias) the PV (measurement value). It can also be used as zero point adjustment of sensor signal.</p>
PV decimal point	<p>It is a function that enables the selection of decimal point function of PV (measurement). Decimal point position can be decided in 5 digits display.</p>
SV decimal point for display	<p>This is a function for changing position of the decimal point of SV at the upper display. For example, when number of digits after decimal point is not displayed, use this function.</p>
Digital filter	<p>It is a filter function on the operation having first order lag in PV (measurement value). Setting value of digital filter is equivalent to time constant (T), and when PV is changed during step condition it is equivalent to the time (seconds) to reach approximately 63%.</p> 

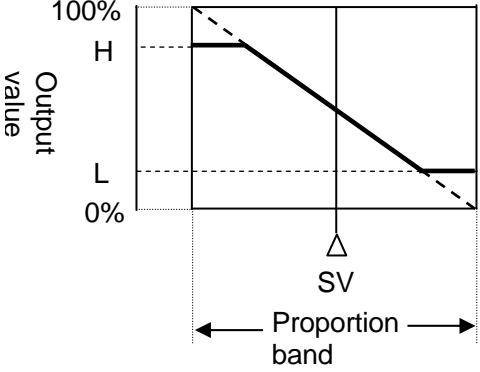
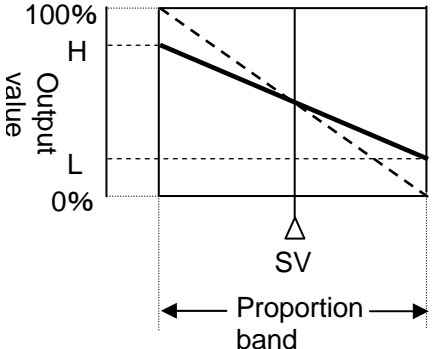
Term	Explanation
Output limiter	<p>It is a function that sets higher limit and lower limit in a range from -5.0 to 105% in MV (output value). MVs (output value) on all the controls, lie within the range of higher limit and lower limit that is set.</p>  <p>The graph shows 'Output value' on the y-axis with markers for 0%, L, and 100%. A dashed line represents the ideal linear relationship. A solid line shows the actual output, which is constant at the higher limit 'H' until it reaches the set value 'SV', then decreases linearly to the lower limit 'L' at the end of the 'Proportion band'.</p>
Output scale	<p>It is a function that lays out MV (output value) from 0.0 to 100%, in a range from higher limit value to lower limit value that is set. All the MVs (output value) on the control, lie within the range of higher limit and lower limit that is set.</p>  <p>The graph shows 'Output value' on the y-axis with markers for 0%, L, and 100%. A dashed line represents the ideal linear relationship. A solid line shows the actual output, which is constant at the higher limit 'H' until it reaches the set value 'SV', then decreases linearly to the lower limit 'L' at the end of the 'Proportion band'.</p>
Output variation limiter	<p>It is a function that limits the variation quantity of MV (output value), for each control cycle (approximately 0.1 seconds). For example when variation in MV is 50% and set value of output variation limiter is 5%, then approximately 0.1 seconds $\times 50 / 5 =$ approximately 1.0 seconds, to arrive to a variation of 50% approximately 1.0 seconds are required.</p> <p>By using this function appropriately, sudden variation in MV (output value) can be avoided and controllability can be improved.</p> <p>However, manual output (include immediately after switching manual to auto) and output during PV abnormality are not effect this function.</p>
Output preset	<p>It is a function that can set MV (output value) when $SV = PV$, when controlling only the P (proportion) operation.</p>
Preset manual	<p>It is a function that can set MV (output value) when the status is READY. Also MV (output value) can be set forcefully as this setting value.</p>
Output at the time of PV abnormality	<p>It is a function that considers forcibly MV (output value) as set value when, PV (measurement value) exceeds the range (including higher limit burnout), is below range (including lower limit burnout).</p> <p>Separate settings can be done in case of over range (including higher limit burnout) and under range (including lower limit burnout). In case of internal data abnormality, MV (output value) is the same as that in case of over range (including higher limit burnout).</p> <p>In case of output 2 specifications, output 2 side is 0% for all conditions.</p>

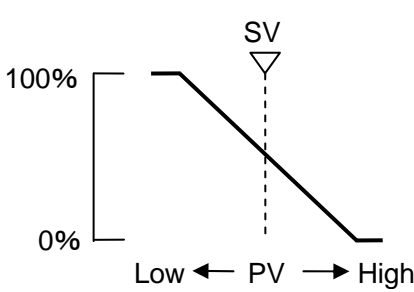
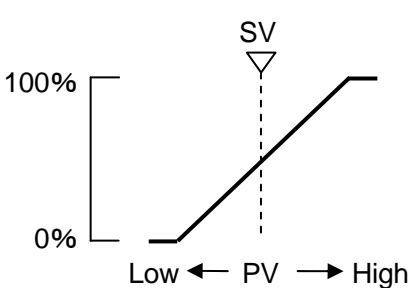
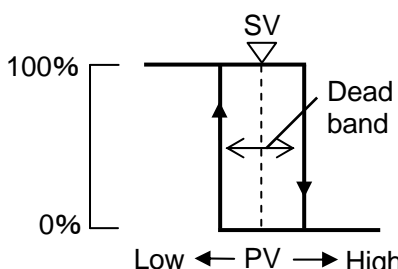
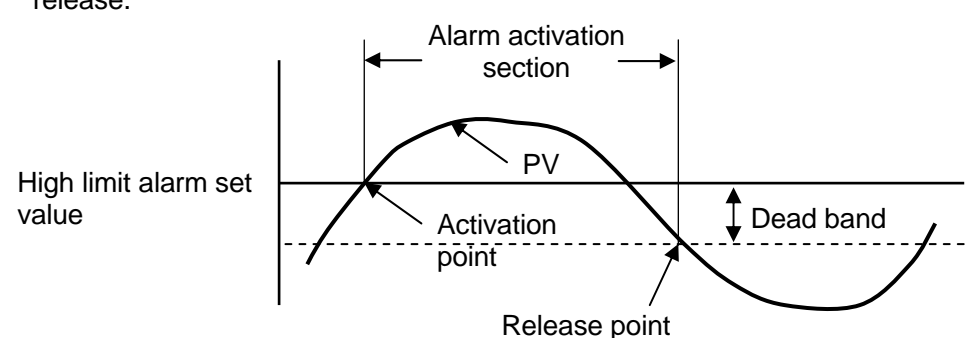
Term	Explanation
Pulse cycle	<p>It is a function that sets one cycle time of output ON/OFF in case of ON-OFF pulse type or SSR drive pulse type.</p> <p>The smaller the set value the better the controllability, however as the ON/OFF count increases the life span of relay etc. decreases. Set the highest possible value in the range such that there is no error in controllability.</p>
Control action	<p>'Reverse operation' is a control action for SV (Setting value) in which the lower the PV (measurement value) the bigger the MV (output value) and it is generally used at the time of heating operation.</p> <p>'Direct operation' is a control action for SV (Setting value) in which the higher the PV (measurement value) the bigger the MV (output value) and it is generally used at the time of cooling operation.</p> <div style="display: flex; justify-content: space-around; align-items: flex-start;"> <div style="text-align: center;"> <p>[Reverse operation]</p>  </div> <div style="text-align: center;"> <p>[Direct operation]</p>  </div> </div>
Output dead band (Two-position control action)	<p>It is a dead band of output operation of two-position control action (when P=0%).</p> <p>The smaller the set value the better the controllability, however as the ON/OFF count increases the life span of relay etc. decreases. Set the highest possible value in the range such that there is no error in controllability.</p> <div style="text-align: right;"> <p>[For reverse operation]</p>  </div>
Alarm dead band	<p>It is a function that, activates the alarm at the alarm setting value during alarm activation and releases the alarm when the dead band that is set in the alarm setting value exceeds the dead band that is set in alarm setting value during alarm release.</p> 

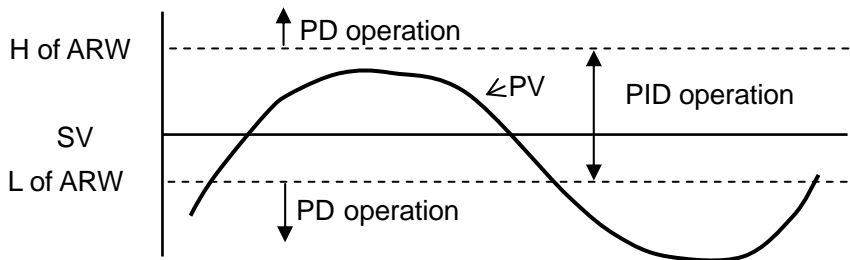
Term	Explanation
Alarm delay	<p>In the function that has delay in alarm output, initial alarm is switched ON when the judgment time of alarm ON is continuously equal to the setting value or more. If the judgment time of alarm ON, is less than the setting value, alarm is not switched ON. For example, if setting value of alarm delay is 5, when alarm is activated continuously for 5 seconds or more, initial alarm is switched ON. However when alarm is released it is switched OFF immediately.</p>
<p>A.R.W (Anti reset windup)</p>	<p>It is a function that decides the range of PID operation (especially I operation) in position type PID control. If this set value is exceeded, it becomes a PD operation.</p> 
PV start	<p>It is one of the functions in slope operation according to the SV change rate. This function is the SV (set value) is started from current PV (measurement value) when recovery from power failure or switch manual operation to auto operation. For example, when PV is 110°C and SV is changed from 100°C to 150°C, at that time the slope operation is started from PV after turning off the power at 105°C that is the middle of the slope of the SV and then turning on the power. In other words, it is started from 110°C in this case. If PV is over range or under range, SV after returning on the power is displayed 150°C of changed value.</p>

15. Accessories

15-1. Front protective cover

It is a cover for protecting the front part and also to protect the keys from being tampered.

During closed installation, it is not mounted but it is with front protective cover, the panel mounting space of the controller is 105 mm or more.

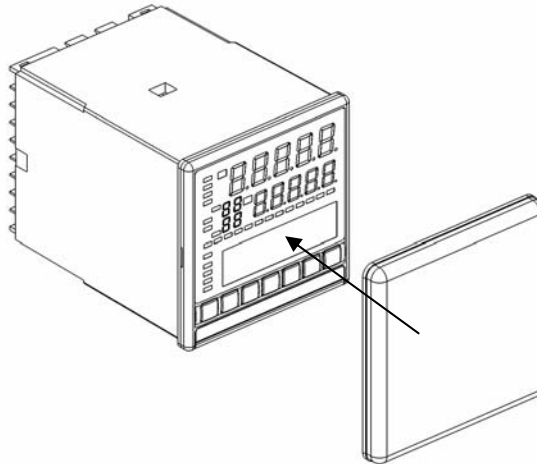

15-2. Contact protection element

Contact protection element is connected for noise rejection to the relay output terminal of the controller. Always do the loading and wiring through contact protection element and buffer relay in relay output like ON-OFF pulse type, ON-OFF servo type and alarm output.

Contact protection element as shown below is available with our company also, use it as per you requirement.

Model	Specifications	Open close current	Application
CX-CR1	0.01 μ F + 120 Ω	Less than 0.2A	For light load
CX-CR2	0.5 μ F + 47 Ω	0.2A or more	For heavy load

While using it, the leak current flows depending on the load power supply as shown below hence take care.

Model	Power voltage: 200V		Power voltage: 100V	
	50Hz	60Hz	50Hz	60Hz
CX-CR1	Approximately 2mA	Approximately 2mA	Approximately 1mA	Approximately 1mA
CX-CR2	Approximately 45mA	Approximately 55mA	Approximately 23mA	Approximately 28mA

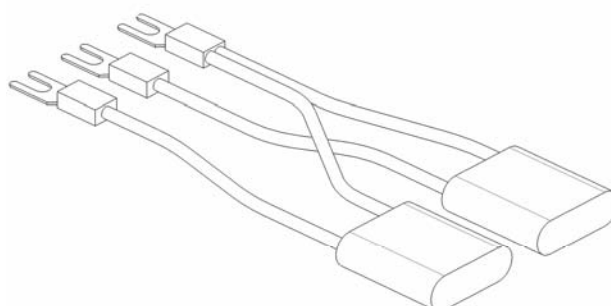

16. Specifications

■ Input specifications

Input signal:

Thermocouple B, R, S, K, E, J, T, WRe5-WRe26,
W-WRe26, NiMo-Ni, CR-AuFe, N, PR5-20,
PtRh40-PtRh20, Platinel II, U, L

DC voltage $\pm 10\text{mV}$, $\pm 20\text{mV}$, $\pm 50\text{mV}$, $\pm 100\text{mV}$,
 $\pm 5\text{V}$, $\pm 10\text{V}$

DC current 0 to 20mA

Resistance thermometer Pt100, JPt100, Old Pt100,
JPt50, Pt-Co (4-wire)

Measurement range: Thermocouple 28 types, DC voltage 6
types, DC current 1 type, resistance
thermometer 14 types

Temperature unit: °C, K

Accuracy rating: $\pm 0.1\% \pm 1$ digit of measurement range

For details see, 'Detailed accuracy rating specifications'.

Reference junction compensation accuracy: $\pm 0.5^\circ\text{C}$

For details see, 'Reference junction compensation accuracy'.

Sampling rate: Approximately 0.1 seconds

Resolution : Approximately 1/30000

Burnout: Restricted to thermocouple, DC voltage (less than
 $\pm 50\text{mV}$), resistance thermometer (3-wire), high limit
burnout is a standard provision. During burnout,
output value of output 1 can be set optionally, output
value of output 2 is 0% and high limit alarm is ON
(during high limit burnout) however DC voltage
($\pm 100\text{mV}$ or more), DC current, resistance
temperature (4 wire system) are not provided.

Input impedance : Thermocouple $1\text{M}\Omega$ or more
DC voltage $1\text{M}\Omega$ or more
Direct current approximately 250Ω

Allowable signal

source resistance : Thermocouple Less than 100Ω
DC voltage (mV) Less than 100Ω
DC voltage (V) Less than 300Ω

Allowable

wire resistance : Resistance thermometer Less than 5Ω
(Should be common for all wires)

Measurement current

of resistance thermometer: Approximately 1mA

Maximum

allowable input : Thermocouple Less than $\pm 20\text{V}$
DC voltage Less than $\pm 20\text{V}$
DC voltage Less than $\pm 30\text{mA}$
Less than $\pm 7.5\text{V}$
Resistance temperature Less than 500Ω ,
Less than $\pm 5\text{V}$

Maximum common mode voltage: Less than 30VAC

Common mode rejection ratio: 130dB or more (50/60Hz)

Normal mode rejection ratio: 50dB or more (50/60Hz)

■ Display specifications

Upper display : LED

Lower display : LCD (with back light) 108x24 dot

■ Control specifications

Control cycle : Approximately 0.1 seconds

Output format : ON-OFF pulse type, ON-OFF servo type,
Current output type, SSR drive pulse type,
voltage output type

ON-OFF pulse type : Output signal ON-OFF pulse conductive signal

Contact capacity Resistance load

Less than 100 to 240VAC and 5A

Less than 30VDC and 5A

Inductive load

Less than 100 to 240VAC and 2.5A

Less than 30VDC and 2.5A

Smallest load

5VDC and 10mA or more

Contact protection Built in a small type of CR device

ON-OFF servo type : Output signal ON-OFF servo inductive signal

Contact capacity of standard load

Resistance load

Less than 100 to 240VAC and 5A

Less than 30VDC and 5A

Inductive load

Less than 100 to 240VAC and 2.5A

Less than 30VDC and 2.5A

Smallest load

5VDC and 10mA or more

Contact capacity of light load

Resistance load

Less than 100 to 240VAC and 20mA

Less than 30VDC and 20mA

Inductive load

Less than 100 to 240VAC and 20mA

Less than 30VDC and 20mA

Smallest load

5VDC and 1mA or more

Contact protection Built in small type of CR device

Current output type Output signal 4 to 20mA

Load resistance Less than 750Ω

SSR drive pulse type Output signal ON-OFF pulse voltage signal

Output voltage ON voltage $12\text{VDC} \pm 20\%$

OFF voltage less than 0.8VDC

Load current Less than 20mA

Voltage output type Output signal 0 to 10V

Output impedance Approximately 10Ω

Load resistance $50\text{k}\Omega$ or more

<p>■ Alarm specifications</p> <p>Alarm points : 4 points</p> <p>Alarm type : Absolute value alarm, deviation alarm, absolute value deviation alarm, setting value alarm, output value alarm, control loop abnormal alarm, FAIL, timer</p> <p>Output signal : Relay output signal (a contact point) Common COM in AL1 and AL2, common COM in AL3 and AL4</p> <p>Contact point capacity Resistance load Less than 100-240VAC and ·3A Less than 30VDC and ·3A</p> <p>Inductive load Less than 100-240VAC and ·1.5A Less than 30VDC and ·1.5A</p> <p>Smallest load 5VDC and ·10mA or more</p> <p>■ General specifications</p> <p>Rated power voltage : General power supply specifications 100 to 240VAC 24V Power supply specifications 24VAC/24VDC</p> <p>Rated power supply frequency : General power supply specifications 50/60Hz 24V Power supply specification DC, 50/60Hz</p> <p>Maximum power consumption:</p> <table style="margin-left: 20px;"> <tr> <td colspan="2">General power supply specifications</td> </tr> <tr> <td>Without option</td> <td>100VAC 10VA 240VAC 15VA</td> </tr> <tr> <td>With option</td> <td>100VAC 15VA 240VAC 20VA</td> </tr> <tr> <td colspan="2">24V Power supply specifications</td> </tr> <tr> <td>Without option</td> <td>24VAC 10VA 24VAC 5W</td> </tr> <tr> <td>With option</td> <td>24VAC 15VA 24VAC 10W</td> </tr> </table> <p>Power failure countermeasures : Storing the setting contents using EEPROM (Rewrite count Less than one million times)</p> <p>Terminal screw : M3.5</p> <p>Insulation resistance</p> <table style="margin-left: 20px;"> <tr> <td>Between primary terminal and secondary terminal</td> <td>20MΩ or more (500VDC)</td> </tr> <tr> <td>Between primary terminal and grounding terminal</td> <td>20MΩ or more (500VDC)</td> </tr> <tr> <td>Between secondary terminal and grounding terminal</td> <td>20MΩ or more (500VDC)</td> </tr> </table> <p>Withstand voltage</p> <table style="margin-left: 20px;"> <tr> <td>Between primary terminal and secondary terminal</td> <td>1500VAC (For 1 minute)</td> </tr> <tr> <td>Between primary terminal and grounding terminal</td> <td>1500VAC (For 1 minute)</td> </tr> <tr> <td>Between secondary terminal and grounding terminal</td> <td>500VAC (For 1 minute)</td> </tr> </table> <p>※ Primary terminal : Terminal of power supply, control output, and alarm output</p> <p>Secondary terminal : All terminals except primary terminal, power supply (24VAC/24VDC)</p> <p>Casing : Fire-retardant Polycarbonate</p> <p>Color : Gray or black</p> <p>Mounting : Panel mounting</p> <p>External dimensions : 96(H) X 96(W) X 127(D) (Depth from panel screen is 120)</p> <p>Weight: Without option Approximately 450g With option Approximately 580g</p>	General power supply specifications		Without option	100VAC 10VA 240VAC 15VA	With option	100VAC 15VA 240VAC 20VA	24V Power supply specifications		Without option	24VAC 10VA 24VAC 5W	With option	24VAC 15VA 24VAC 10W	Between primary terminal and secondary terminal	20MΩ or more (500VDC)	Between primary terminal and grounding terminal	20MΩ or more (500VDC)	Between secondary terminal and grounding terminal	20MΩ or more (500VDC)	Between primary terminal and secondary terminal	1500VAC (For 1 minute)	Between primary terminal and grounding terminal	1500VAC (For 1 minute)	Between secondary terminal and grounding terminal	500VAC (For 1 minute)	<p>■ Safety standards</p> <p>CE approval: EN61326: 1997 +A1+A2+A3 EN61010-1:2001 (Over voltage category II, pollution level 2)</p> <p>※ Due to the test condition of EMC directive, indication value or output value which is equivalent to maximum ±10% or maximum ±2mV which ever is greater, changes.</p> <p>UL file No. : E214646</p> <p>UL :UL61010-1 2nd edition</p> <p>c-UL :CAN/CSA C22.2 No.61010-1-04</p> <p>■ Reference operation condition</p> <p>Surrounding temperature : 23°C±2°C</p> <p>Surrounding humidity : 55%RH±5% (With no condensation)</p> <p>Power voltage : General power supply specifications 100VAC±1% 24V Power supply specifications 24VDC±1%</p> <p>Power supply frequency : General power supply specifications 50/60Hz±0.5% 24V Power supply specifications DC</p> <p>Mounting orientation : Forward or backward ±3°, lateral ±3°</p> <p>Set up height : Altitude below 2000m</p> <p>Vibrations : 0m/s²</p> <p>Shocks : 0m/s²</p> <p>Mounting condition : Simple panel mounting (There should be a space above below and to the right and left)</p> <p>Wind : None</p> <p>External noise : None</p> <p>Warm up time : 30 minutes or more</p> <p>■ Normal operation condition</p> <p>Surrounding temperature : -10°C to 50°C (-10°C to 40°C for closed installation)</p> <p>Surrounding humidity : 10 to 90%RH (With no condensation)</p> <p>Power voltage : General power supply specifications 90 to 264VAC 24V Power supply specifications 21.6 to 26.4VDC/AC</p> <p>Power supply frequency : General power supply specifications 50/60Hz±2% 24V Power supply specifications DC, 50/60Hz±2%</p> <p>Mounting orientation : Forward or backward±10°, lateral±10°</p> <p>Set up height : Altitude below 2000m</p> <p>Vibrations : 0m/s²</p> <p>Shocks : 0m/s²</p> <p>Mounting condition : Simple panel mounting (There should be a space above and below)</p> <p>External noise : None</p> <p>Surrounding temperature variation ratio : Less than 10°C/hour</p>
General power supply specifications																									
Without option	100VAC 10VA 240VAC 15VA																								
With option	100VAC 15VA 240VAC 20VA																								
24V Power supply specifications																									
Without option	24VAC 10VA 24VAC 5W																								
With option	24VAC 15VA 24VAC 10W																								
Between primary terminal and secondary terminal	20MΩ or more (500VDC)																								
Between primary terminal and grounding terminal	20MΩ or more (500VDC)																								
Between secondary terminal and grounding terminal	20MΩ or more (500VDC)																								
Between primary terminal and secondary terminal	1500VAC (For 1 minute)																								
Between primary terminal and grounding terminal	1500VAC (For 1 minute)																								
Between secondary terminal and grounding terminal	500VAC (For 1 minute)																								

<p>■ Transport conditions</p> <p>Surrounding temperature : -20°C to 60°C</p> <p>Surrounding humidity : 5 to 90%RH (With no condensation)</p> <p>Vibrations : 4.9m/s² (10 to 60Hz)</p> <p>Shocks : 392m/s²</p> <p>However these are the factory shipping packing conditions.</p> <p>■ Storage conditions</p> <p>Surrounding temperature : -20°C to 60°C</p> <p>However temperature for long term preservation is 10°C to 30°C.</p> <p>Surrounding humidity : 5 to 90%RH (With no condensation)</p> <p>Vibrations : 0m/s²</p> <p>Shocks : 0m/s²</p> <p>However this is the factory shipping packing status.</p> <p>■ Option</p> <p>[Transmission signal output]</p> <p>Number of outputs : Maximum 2 points</p> <p>Output signal : 4-20mA (Load resistance Less than 400Ω)</p> <p style="padding-left: 40px;">0-1V (Output impedance Approximately10Ω)</p> <p style="padding-left: 80px;">(Load resistance More than 50kΩ)</p> <p style="padding-left: 40px;">0-10V (Output impedance Approximately10Ω)</p> <p style="padding-left: 80px;">(Load resistance More than 50kΩ)</p> <p>Accuracy rating : High-performance type ±0.1%FS</p> <p style="padding-left: 40px;">General type ±0.3%FS</p> <p>Resolution : High-performance type Approximately 1/30000</p> <p style="padding-left: 40px;">General type Approximately 1/15000</p> <p>Output update period : Approximately 1 second</p> <p>Insulation : Internal circuit is insulated (More than 20MΩ and 500VDC)</p> <p style="padding-left: 40px;">Transmission signal outputs are also insulated</p> <p>[Transmitter power supply]</p> <p>Power supply voltage : 24VDC±10%</p> <p>Maximum current capacity : Less than 30mA</p> <p>Insulation : Internal circuit is insulated (20MΩ or more and 500VDC)</p> <p>[Remote signal input]</p> <p>Input points : 1 point</p> <p>Input signal : 4 to 20mA (Input impedance approximately 50Ω)</p> <p style="padding-left: 40px;">0 to 1V (Input impedance approximately 500kΩ)</p> <p style="padding-left: 40px;">0 to 10V (Input impedance approximately 100kΩ)</p> <p>Maximum allowable input</p> <p style="padding-left: 40px;">: DC current less than ±30mA, less than ±1.5V</p> <p style="padding-left: 40px;">DC voltage Less than ±20V</p> <p>Accuracy rating :±0.1%FS±1digit</p> <p>Resolution : Approximately 1/30000</p> <p>Sampling rate : Approximately 0.1 seconds</p> <p>External signal input : R/L (Remote/local)</p> <p>Insulation : Internal circuit is insulated (20MΩ or more and 500VDC)</p>	<p>[Communications interface]</p> <p>Communications points : Maximum 2 points</p> <p>Communications types : RS232C, RS422A, RS485</p> <p>Protocol : MODBUS(RTU), MODBUS(ASCII), PRIVATE</p> <p>External signal input : R/L (Remote/local)</p> <p>Insulation : Internal circuit is insulated (20MΩ or more and 500VDC)</p> <p style="padding-left: 40px;">Communications interface points are not insulated</p> <p>[Heater snapping wire alarm]</p> <p>Measurement scope : 10 to 100AAC (50/60Hz)</p> <p>Accuracy rating : ±5.0%FS±1digit</p> <p>CT : Manufactured by U-RD Limited'CTL-12-S36-8'</p> <p>[Output 2]</p> <p>Control period : Approximately 0.1 second</p> <p>Output format : Arbitrary combination using ON-OFF pulse</p> <p style="padding-left: 40px;">format, current output format, voltage output</p> <p style="padding-left: 40px;">format, SSR drive pulse format is possible</p> <p>Control system : PID system, SPRIT system</p> <p>Insulation : Internal circuit is insulated (20MΩ or more and 500VDC)</p> <p style="padding-left: 40px;">Not insulated between outputs (Only ON-OFF pulse type is insulated)</p> <p>[External signal input]</p> <p>Input points : Maximum 20 points</p> <p>Input signal : Voltage contact point, open collector output</p> <p>External contact point capacity : 5VDC and 2mA</p> <p>Function : Selecting execution number (SV No.)</p> <p style="padding-left: 40px;">(4 points SV1/SV2/SV4/SV8)</p> <p style="padding-left: 40px;">Manual output operation/automatic output operation</p> <p style="padding-left: 40px;">(2 points MAN1/AUTO1 and MAN2/AUTO2)</p> <p style="padding-left: 40px;">READY/RUN</p> <p style="padding-left: 40px;">HOLD of PV</p> <p style="padding-left: 40px;">HOLD of SV slope operation</p> <p style="padding-left: 40px;">RESET of SV slope operation</p> <p style="padding-left: 40px;">Start/RESET timer</p> <p style="padding-left: 40px;">(4 points TIMER1/TIMER2/TIMER3/TIMER4)</p> <p style="padding-left: 40px;">Cancel alarm output</p> <p style="padding-left: 40px;">Preset manual/automatic output operation</p> <p>Insulation : Internal circuit is insulated (20MΩ or more and 500VDC)</p> <p style="padding-left: 40px;">Not insulated between external signal input points</p> <p>[Panel sealing]</p> <p>Equivalent to IEC60529 IP54</p> <p>(Not possible during closed instrumentation)</p> <p>[Terminal cover]</p> <p>Cover the terminals for safe.</p>
---	--

■ Detailed specifications of accuracy rating

Input type		Accuracy rating	Exceptional specifications	
Thermocouple	B	±0.1%FS ±1digit	0 to 400°C : Out of specifications 400 to 800°C : ±0.2%FS ±1digit	
	R, S		0 to 400°C : ±0.2%FS ±1digit	
	N			
	K		-200 to 0°C : ±0.2%FS ±1digit or ±60μV equivalent value, whichever is bigger	
			-270 to 0°C : ±0.2%FS ±1digit or ±80μV equivalent value, whichever is bigger	
	E		-200 to 0°C : ±0.2%FS ±1digit or ±80μV equivalent value, whichever is bigger	
	J		-270 to 0°C : ±0.2%FS ±1digit or ±40μV equivalent value, whichever is bigger	
	T		-200 to 0°C : ±0.2%FS ±1digit or ±40μV equivalent value, whichever is bigger	
	L		-200 to 0°C : ±0.2%FS ±1digit	
	WRe5-WRe26			
	W-WRe26		0 to 400°C : ±0.3%FS ±1digit	
	NiMo-Ni			
	Platinel II			
	CR-AuFe		±0.2%FS ±1digit	0 to 20K : ±0.5%FS ±1digit 20 to 50K : ±0.3%FS ±1digit
	PR5-20			0 to 100°C : Out of specifications 100 to 200°C : ±0.5%FS ±1digit
	0 to 400°C : ±1.5%FS ±1digit			
PtRh40-PtRh20	400 to 800°C : ±0.8%FS ±1digit			
DC voltage/DC current		±0.1%FS ±1digit		
Resistance thermometer	Pt100 Old Pt100 JPt100	±0.1%FS ±1digit	Applicable only when measurement range is "-100 to 100°C, -100 to 100°C : ±0.15%FS ±1digit	
	JPt50			
	Pt-Co	±0.15%FS ±1digit	4 to 20K : ±0.5%FS ±1digit 20 to 50K : ±0.3%FS ±1digit	

※ It is the measurement range conversion accuracy in reference operation condition. Thermocouple adds to reference junction compensation accuracy.

- ※ K, E, J, T, R, S, B, N : IEC584 (1977, 1982), JIS C 1602 – 1995, JIS C 1605 – 1995
WRe5-WRe26, W-WRe26, NiMo-Ni, Platinel II, CR-AuFe, PtRh40-PtRh20 : ASTM Vol.14.03
U, L: DIN43710-1985
Pt100Ω: IEC751 (1995), JIS C 1604-1997
Old Pt100Ω: IEC751 (1983), JIS C 1604-1989, JIS C 1606-1989
JPt100Ω: JIS C 1604-1981, JIS C 1606-1986
JPt50Ω: JIS C 1604-1981

■ Reference junction compensation accuracy

Thermocouple type	Surrounding temperature: 23°C±10°C	Surrounding temperature: Range other than mentioned on left
K, E, J, T, N, Platinel II	±0.5°C Or ±20μV equivalent value, whichever is bigger	±1.5°C Or ±60μV equivalent value, whichever is bigger
Other than mentioned above	±1.0°C Or ±40μV equivalent value, whichever is bigger	±3.0°C Or ±120μV equivalent value, whichever is bigger

※ It is the compensation accuracy when measurement input value is 0°C. In case of measurement value other than 0°C, above-mentioned electromotive force conversion equivalent value is considered as the compensation accuracy.

17. Parameter list

[Parameters not related to execution numbers]

Mode No.	Setting Item	Default value (During factory shipping)	Customer setting value	Setting range	
0	Executing S V	0000.0		SV range	
	Executing PID	P	005.0%	000.0 to 999.9 (0 is two-position control)	
		I	0060s	0000 to 9999 (0 means ∞)	
		D	0030s	0000 to 9999 (0 means OFF)	
	Executing alarm1 and alarm 2	AL1	3000.0	-1999.9 to 3000.0	
		AL2	-1999.9		
Executing alarm 3 and alarm 4	AL3	3000.0			
	AL4	-1999.9			
1	RUN/READY switching	RUN		RUN, READY	
	Cancel alarm	NON		NON, RESET	
	Remote/local switching	LOCAL		LOCAL, REMOTE	
	Select execution number	1		1 to 8	
	Auto tuning	END		END, AT1, AT2, AT3, AT4	
	Select PIDNo. system	No.1 to 8		No.1-8, No.9	
	Select simple function/multiple functions	MULTI		SIMPLE, MULTI	
	P V hold	NON		NON, HOLD	
	Operation at the time of starting the power supply	CONTINUE		CONTINUE, READY	
	Existence of CT screen	NON		NON, DISPLAY	
2	S V change rate	UP	0000.0	0000.0 to 2000.0	
		DW	0000.0	-1999.9 to 0000.0	
		Time	M	H (Hours), M (Minutes), S (Seconds)	
	S V range	-200.0 to 1370.0		-1999.9 to 3000.0	
	Remote scale	0000.0 to 2000.0		-1999.9 to 3000.0	
	Remote filter	00.0s		00.0 to 99.9	
	Cascade constant	r	1.00		0.00 to 1.00
		b	000.0%		-99.9 to 100.0
Existence of tracking	OFF		ON, OFF		
3	Output dead band	PID	0.0%	0.0 to 9.9	
		P=0	0.5%	0.1 to 9.9	
	Output 2 PID	P	005.0%		000.0 to 999.9 (0 is two-position control)
		I	0060s		0000 to 9999 (0 means ∞)
		D	0030s		0000 to 9999 (0 means OFF)
	Output 2 gap	000.0%		-100.0 to 100.0	
	Output 2 output dead band	PID	0.0%		0.0 to 9.9
		P=0	0.5%		0.1 to 9.9

Mode No.	Setting item		Initial value (During factory shipping)	Customer setting value	Setting range
3	Alarm format of alarm 1 and alarm 2	AL1	DV-H		PV, DV, ADV, SV, MV (MV1, MV2) H, HW, HK, HWK L, LW, LK, LWK CT, LOOP, TIMER, FAIL
		AL2	DV-L		
	Alarm format of alarm 3 and alarm 4	AL3	DV-H		
		AL4	DV-L		
	Alarm dead band	AL1	002.00		000.00 to 200.00
		AL2	002.00		
		AL3	002.00		
		AL4	002.00		
	Alarm delay		0000.0s		0000.0 to 2000.0
	Control loop abnormal alarm judgment time		03600s		00000 to 20000
	A.R.W.	L	-050.0%		-100.0 to 000.0
H		050.0%		000.0 to 100.0	
AT2, AT3 start direction		UP		UP, DOWN	
Control algorithm		POSITION		POSITION, VELOCITY	
4	Pulse cycle		030s		001 to 180
	Output 2 pulse cycle		030s		001 to 180
	FB tuning		END		END, START
	FB zero span	Z	00.0%		00.0 to 99.9
		S	100.0%		000.1 to 100.0
	F B dead band		1.0%		0.5 to 5.0
	Output when PV is abnormal	OVR	000.0%		-05.0 to 105.0
		UDR	000.0%		
	Output 2 limiter (Or output 2 scale)	L	000.0%		-05.0 to 100.0
		H	100.0%		00.0 to 105.0
	Direct/reverse control action		REVERSE		DIRECT, REVERSE
	Direct/reverse output 2 control action		DIRECT		DIRECT, REVERSE
	Preset manual		000.0%		-005.0 to 105.0
	Output 2 preset manual		000.0%		-005.0 to 105.0
Output 2 control system		PID		PID, SPRIT	
Sprit	DIR	00.0%		00.0 to 60.0	
	REV	100.0%		040.0 to 100.0	
5	Measurement range	Universal	K1		See 'Measurement list'
		4-wire resistance thermometer	Pt100Q1		See 'Measurement list'
	Unit		°C		°C, K
	RJ		INT		INT, EXT
	Digital filter		00.1s		00.0 to 99.9
	P V decimal point		1		0 to 4
	Measurement scope		-200.0to1370.0		Scale scope of measurement range
	Linear scale	DOT	1		0 to 4
Scale		0000.0 to 2000.0		-1999.9 to 3000.0	
SV decimal point for display		1		0 to 4	
6	Transmission type (High-performance type)		PV		PV, SV, MV(MV1, MV2), MFB, RSV

Mode No.	Setting item	Initial value (During factory shipping)	Customer setting value	Setting range
6	Transmission scale (High-performance type)	-0200.0 to 1370.0		-1999.9 to 3000.0
	Transmission type (General type)	PV		PV, SV, MV (MV1, MV2), MFB, RSV
	Transmission scale (General type)	-0200.0 to 1370.0		-1999.9 to 3000.0
7	Communication speed	9600bps		2400, 4800, 9600, 19200, 38400
	Instrument number	01		01 to 99
	Communication function	COM		COM, REM, TRANS
	Communication transmission type	PV		PV, SV, MV(MV1, MV2), MFB, RSV
	Communication protocol	MODBUS(RTU)		MODBUS(RTU), MODBUS(ASCII), PRIVATE
	Communication character	8BIT/NON/STOP1		7BIT/EVEN/STOP1 - - - 8BIT/ODD/STOP2
	Select communication 2 port function	ENG		COM·ENG
	Communication speed 2 for COM2	9600bps		2400, 4800, 9600, 19200, 38400
	Instrument number for COM2	01		01 to 99
	Communication function for COM2	COM		COM, REM, TRANS
	Communication transmission type for COM2	PV		PV, SV, MV(MV1, MV2), MFB, RSV
	Communication protocol for COM2	MODBUS(RTU)		MODBUS(RTU), MODBUS(ASCII), PRIVATE
Communication character for COM2	8BIT/NON/STOP1		7BIT/EVEN/STOP1 - - - 8BIT/ODD/STOP2	
11	Display backlight	AUTO		GREEN, ORANGE, AUTO
	Display contrast	050%		000 to 100
	Key backlight	AUTO		AUTO, OFF, ON
	External signal layout	No allocation		See 'External signal input'
	Testing alarm output	OFF		OFF, AL1, AL2, AL3, AL4
12	Measurement range zero correction	00.000		-19.999 to 20.000
	Measurement range span correction	1.0000		0.9000 to 1.1000
	Output 1 zero correction	00.000		-10.000 to 10.000
	Output 1 span correction	1.0000		0.9000 to 1.1000
	Output 2 zero correction	00.000		-10.000 to 10.000
	Output 2 span correction	1.0000		0.9000 to 1.1000
	Remote input zero correction	00.000		-19.999 to 20.000
	Remote input span correction	1.0000		0.9000 to 1.1000
	Transmission output (High-performance type) zero correction	00.000		-10.000 to 10.000
	Transmission output (High-performance type) span correction	1.0000		0.9000 to 1.1000
	Transmission output (General type) zero correction	00.000		-10.000 to 10.000
	Transmission output (General type) span correction	1.0000		0.9000 to 1.1000
CT input zero correction	00.000		-10.000 to 10.000	
CT input span correction	1.0000		0.9000 to 1.1000	

[Parameters related to execution numbers]

Mode No.	Setting item		Initial value (During factory shipping)	Customer setting value (Execution number)								Setting range
				1	2	3	4	5	6	7	8	
2	S V		0000.0									SV range
	Remote shift		000.00									-199.99 to 200.00
3	PID	P	005.0%									000.0 to 999.9
		I	0060s									0000 to 9999
		D	0030s									0000 to 9999
	Alarm 1 and alarm 2	AL1	3000.0									-19999 to 30000
		AL2	-1999.9									
	Alarm 3 and alarm 4	AL3	3000.0									
AL4		-1999.9										
4	Output preset		050.0%									-100.0 to -100.0
	Output variation limiter	UP	100.0%									000.1 to 100.0
		DOWN	-100.0%									-100.0 to -000.1
	Output limiter (Or output scale)	L	000.0%									-05.0 to 100.0
H		100.0%									000.0 to 105.0	
5	Sensor correction		000.00									-199.99 to 200.00

[Parameters related to auto tuning]

Mode No.	Setting item		Initial value (During factory shipping)	Customer setting value (Execution number)								Setting range
				1	2	3	4	5	6	7	8	
3	SV for AT2	Execution	Only No.1 is ON									ON, OFF
		SV	Auto development									-19999 to 30000
	AT3 for SV	Execution	OFF									ON, OFF
		SV	Auto development									Automatic PID switching system SV section range

[Parameters related to automatic PID switching system]

Mode No.	Setting item		Initial value (During factory shipping)	Customer setting value (Execution number)								Setting range
				9-1	9-2	9-3	9-4	9-5	0-6	9-7	9-8	
3	P I D	P	005.0%									000.0 to 999.9
		I	0060s									0000 to 9999
		D	0030s									0000 to 9999
	Automatic PID switching system SV section		Auto development									Measurement range, linear scale

18. Parameter directory

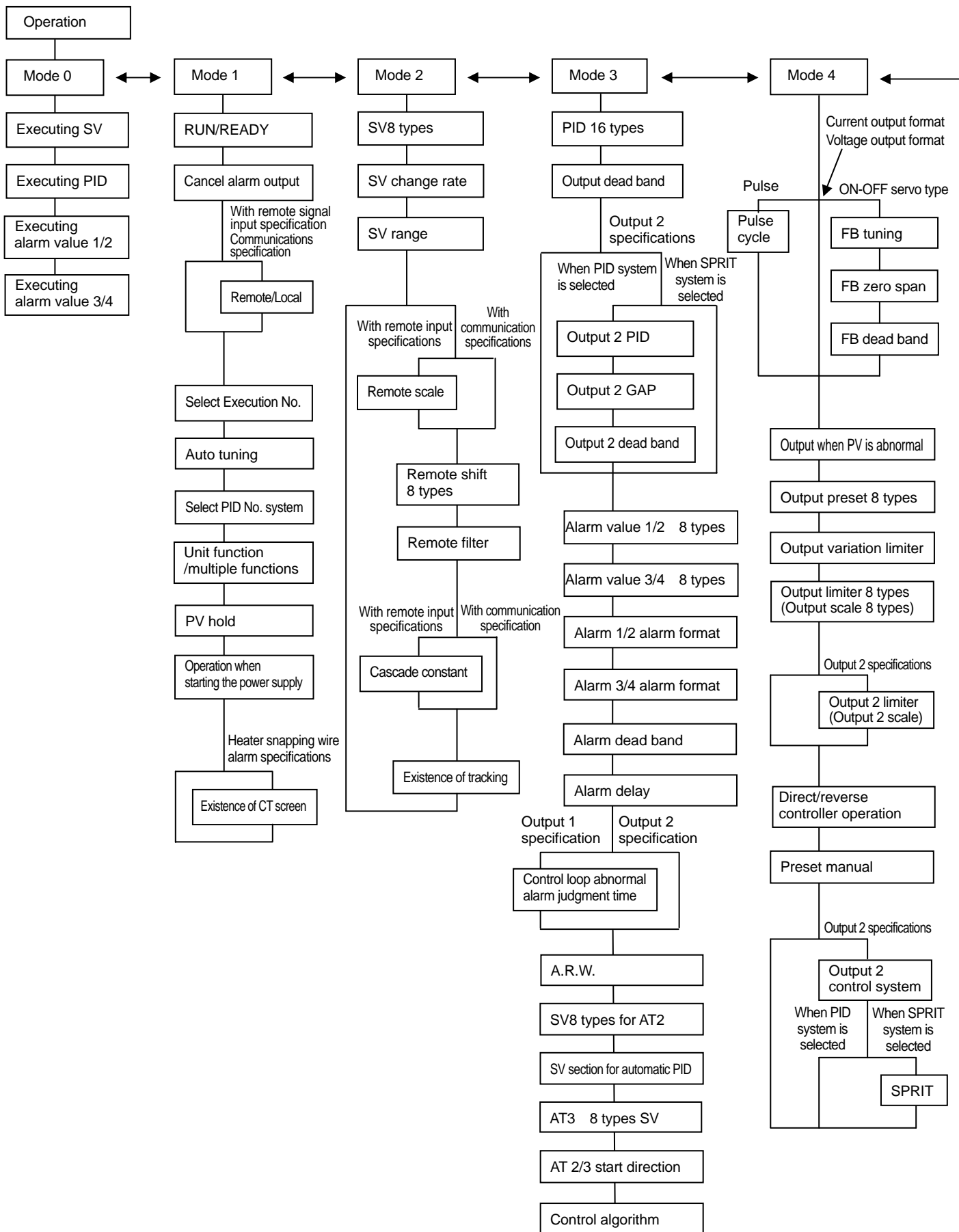

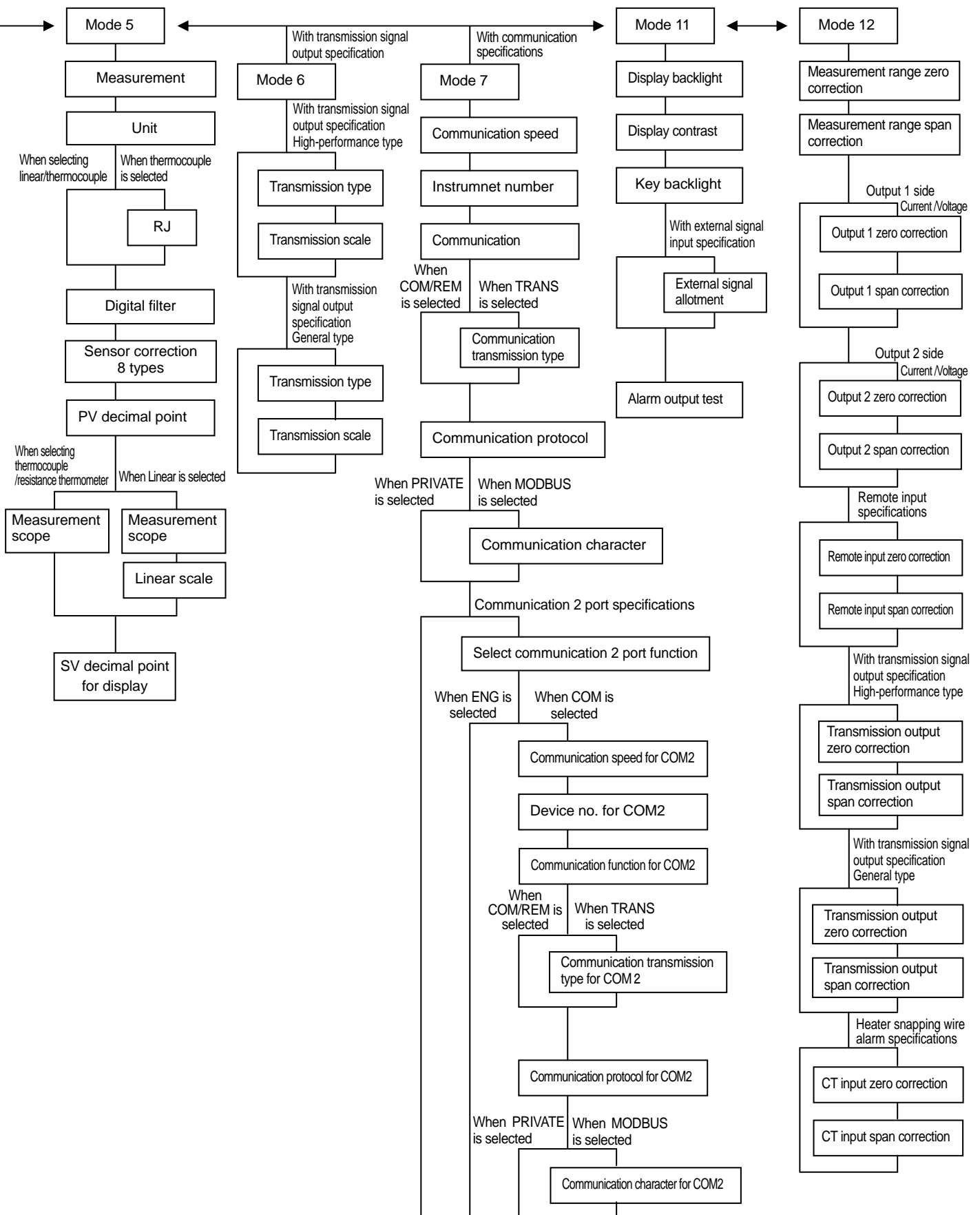

19. Engineering unit sticker

The controller is supplied with sticker for engineering unit. Fix it in the appropriate position as shown in the upper display as per your convenience.

Then if long time has passed after fixing this sticker, there may be peeling-off of the sticker or degradation of character printing due to adhesion degradation.



Precaution

Unincorporated measurement units that are not decided by the measurement laws are included in this unit seal.

CHINO

CHINO CORPORATION

32-8,KUMANO-CHO,ITABASHI-KU,TOKYO 173-8632

Telephone:81-3-3956-2171

Facsimile:81-3-3956-0915

E-mail: inter@chino.co.jp

