

The logo for CHINO, consisting of the word "CHINO" in a bold, white, sans-serif font centered within a dark gray rectangular background.

OPTIONS
[MATH FUNCTION]
[TOTALIZER]
[FLOW CORRECTION]

FOR AL/AH3000 SERIES
HYBRID RECORDER

A standard 1D barcode with vertical black bars of varying widths on a white background.

INSTRUCTIONS

Retain this manual apart from the
instrument and in an easily accessible.

Please make sure that this manual is handed to the final user of the instrument.

TABLE OF CONTENTS

Introduction	1
1. Separate manuals	1
2. 'Data communications input' by keys	1
[1] Math functions	1
1. Types of math functions	1
2. Programming	3
2.1 Printing channel for computed result	3
2.2 Printing range	3
2.3 Decimal place for display and printing	3
2.4 Computation of maximum, minimum and average values	3
3. Programming flow chart	4
3.1 Types of math function and their flow chart	4
3.2 Square root, logarithm, exponential, absolute value and data communications input	5
3.3 Arithmetic computation 1	6
3.4 Arithmetic computation 2	8
3.5 Computation of maximum, minimum and average values	10
3.6 Computation of temperature/humidity	12
[2] Totalizing	14
1. Math expression for totalizing computation	14
2. Programming	14
2.1 Resetting of totalizing computation	14
2.2 Overflow of totalized value	14
2.3 Operation at power failure recovery	15
2.4 Interval time	15
2.5 Starting time of totalizing computation	15
2.6 Printing range	15
2.7 Decimal place for display and printing	15
3. Programming flow chart	16
[3] Flow correction	18
1. Correction computation types and math expressions	18
1.1 Flow correction computation 1 (FloW1)	18
1.2 Flow correction computation 2 (FloW2)	18
1.3 Flow correction computation 3 (FloW3)	18
1.4 Flow correction computation 4 (FloW3)	19
1.5 Flow correction computation 5 (FloW5)	19
1.6 Flow correction computation 6 (FloW6)	19
1.7 Flow correction computation 7 (FloW7)	19
2. Programming	20
2.1 Printing range	20
2.2 Decimal place for display and printing	20
2.3 Abnormal data	20
3. Programming flow chart	22
[4] List printing	24
[Appendix] Conversion table for temperature/humidity computation	25

Introduction

This manual is only for the optional specifications of 'Math function', 'Totalizer' and 'Flow correction' of AL3000 and AH3000 series hybrid recorders. For the standard functions and other optional specifications, please refer the separate manuals.

1. Separate manuals

1) Standards

AL3000 series (Multi-point type)	INE-270□
AH3000 series (Multi-point type)	INE-271□
AL3000 series (Pen type)	}
AH3000 series (Pen type)		
		INE-308□

2) Option

Communications interface	INE-272□
--------------------------	-------	----------

[Note] - □ is the Revision No.

2. 'Data communications input' by keys

'Data communications input' can be programmed with keys when the 'Math function' (option) and 'Communications interface' (option) are combined. However, for the option of 'Communications interface', it is programmed through communications only.

[1] Math functions

The measured data of each channel can be computed and their results are displayed and printed.

The alarm setpoints in the channel Nos. for computed results are programmed for the computed values.

1. Types of math functions

TYPE	MATH EXPRESSION	SET VALUE * 1
1. non (no computation)	—	—
2. mUL (Arithmetical computation 1)	$Ax + By + Cxy + D$ A, B, C, D : Constant x, y : Measured values	<ul style="list-style-type: none"> • Channel No. for computed result • Constant (A, B, C, D) • Channel No. for measured values (x, y)
3. diV * 2 (Arithmetical computation 2)	$Ax / y + B$ A, B : Constant x, y : Measured values	<ul style="list-style-type: none"> • Channel No. for computed result • Constant (A, B) • Channel No. for measured values (x, y).
4. LoGE (Natural Logarithm)	$LOG_e x$ x : Measured value	<ul style="list-style-type: none"> • Channel No. for measured value (x) • (= Channel No. for computed result)
5. LoG10 (Logarithm)	$LOG_{10} x$ x : Measured value	<ul style="list-style-type: none"> • Channel No. for measured value (x) • (= Channel No. for computed result)
6. PoWEr (Exponential)	e^x x : Measured value	<ul style="list-style-type: none"> • Channel No. for measured value (x) • (= Channel No. for computed result)

TYPE	MATH EXPRESSION	SET VALUE * 1
7. root * 3 (Square root)	$(S_s - S_z) \sqrt{\frac{R_x - R_z}{R_s - R_z}} + S_z$ <div style="border-left: 1px solid black; border-right: 1px solid black; padding: 5px; margin-top: 5px;"> R_x : Voltage value of measuring input R_s : Maximum limit for range setting R_z : Minimum limit for range setting S_s : Maximum limit for scale setting S_z : Minimum limit for scale setting </div>	<ul style="list-style-type: none"> Channel No. for voltage value of measuring input (R_x) (= Channel No. for computed result)
8. Humidity (Humidity)	Measured values of dry bulb (x) and wet bulb (y) and humidity is computed by the relative humidity table. x, y : Measured values	<ul style="list-style-type: none"> Channel No. for computed result Channel No. for measured values (x, y).
9. Hi PEAK (Maximum value)	Maximum value of measured values (x) during an interval	<ul style="list-style-type: none"> Channel No. for computed result Interval Starting time Channel No. for measured value (x)
10. Lo PEAK (Minimum value)	Minimum value of measured values (x) during an interval	
11. AVErAGE (Average value)	Average value of measured values (x) during an interval	
12. AbS *6 (Absolute value)	$ x $ x : Measured value	<ul style="list-style-type: none"> Channel No. for measured value (x) (= Channel No. for computed result)
13. int * 4 (Totalizer)	This is only applicable for the "Totalizer" (option). Refer to Section [2] for details.	
14. Comm in * 5 (Data communications input)	Nil [Only displayed for the "communications interface" (option)]	<ul style="list-style-type: none"> Channel for data communications input
15-21 *6 FLoW1 to FLoW7 (Flow correction 1 to 7)	This is only applicable for the "Flow correction" (option). Refer to Section [3] for details.	

*1 : Setting of printing rage is necessary for all math functions from 2 to 21.

*2 : When the measured value (y) is 0, the value (Ax) becomes as bellow.

if $Ax > 0$ then OVER
 if $Ax = 0$ then 0
 if $Ax < 0$ then -OVER

*3 : The math expression shown in the right side is applied when the measuring input voltage (R_x) is 1% or more of the setting range ($R_s - R_z$). When it is less than 1%, it becomes and is fixed to the minimum value of scale setting (S_z).

*4 : Refer to Section 2 item 14 for the 'Totalizer' (option).

*5 : When the 'Math-function' (option) and 'Communications Interface' (option) are combined, the data communications input can be set by keys.

*6 : Only pen type.

2. Programming

2.1 Printing channel for computed result

- 1) Math functions of which computed results are only printed in the channels Nos. of measured value
The computed result by the math functions of square root, natural logarithm, logarithm, absolute value, and exponential is only printed in the channel No. of measured value (x). Therefore the measured value (x), which these 5 math functions are applied to, cannot be printed.
- 2) Math functions of which computed results can be printed in any channels
The computed result by other math functions than the above 5 kinds can be printed in any channels including the channel of measured value. However, if the channel of measured value is selected, the measured value cannot be printed.

2.2 Printing range

The printing range of the channel for computed result is "Printing range" programmed by math function programming, not by range programming.

2.3 Decimal place for display and printing

The decimal place is decided by "Printing range" programmed by math function programming. If the decimal place differs in the maximum and minimum values, the fewer decimal places is effective.

2.4 Computation of maximum, minimum and average values

- 1) Resetting of computation
The computation is automatically reset after the programmed interval time. Accordingly maximum, minimum and average values in each interval time are computed.
- 2) Operation at power failure recovery
 1. If the power is recovered in the programmed interval time, the computation continues.
 2. If the power is not recovered in the programmed interval time, the computation is canceled and starts again from the recovery time.
 3. The judgment of power failure is within 24 hours. If the power failure continues longer than 24 hours, the computation is canceled irrespective the recovery time and starts again from the recovery time.
- 3) Starting time of computation
The starting time is only valid for the first operation after its setting. The computation starts from the starting time.

3. Programming flow chart

3.1 Types of math function and their flow charts

The programming flow chart differs on the type of math function.

Type of math function	Item No. (Page)
MuL (Arithmetic computation 1)	3.3 (page 6)
diV (Arithmetic computation 2)	3.4 (page 8)
LoGE (Natural logarithm)	3.2 (page 5)
LoG10 (Logarithm)	3.2 (page 5)
PoWER (Exponential)	3.2 (page 5)
Root (Square root)	3.2 (page 5)
Humidity (Humidity)	3.6 (page 12)
Hi PEAK (Maximum value)	3.5 (page 10)
Lo PEAK (Minimum value)	3.5 (page 10)
AVErAGE (Average value)	3.5 (page 10)
AbS (Absolute value)	3.2 (page 5)
Comm in (Data communications port)	3.2 (page 5)

3.2 Square root, logarithm, exponential, absolute value and data communications input

(Ex.) To execute the square root computation for the measured value of Channel 2 and program the printing range to 0.0 to 100.0

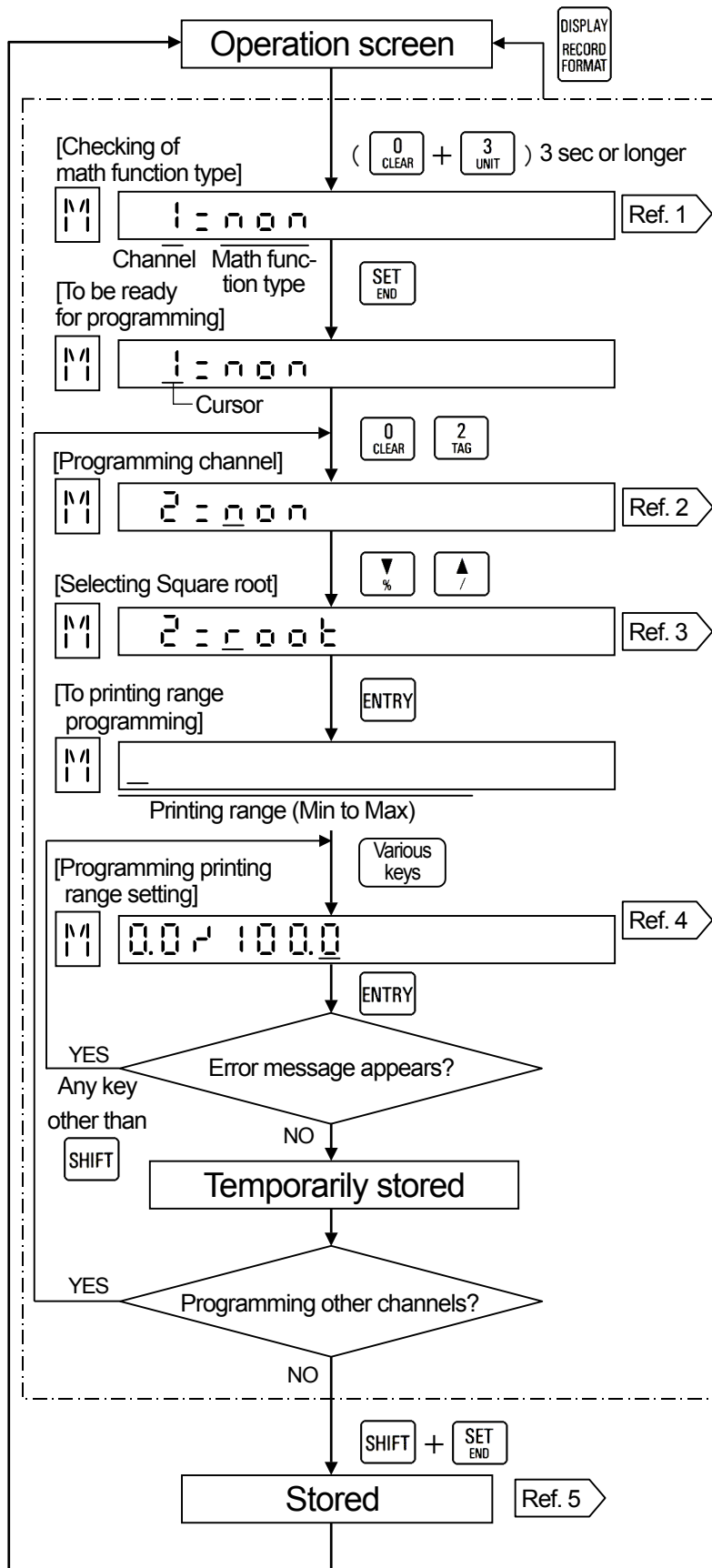

Ref. 1 Checking of other channels
 You can check the math function type of other channels. Press **▼%** or **▲/** to change channels.

Ref. 2 Channel digit
 In AH3000 series multi-point type, a channel is programmed by two digits (06/12/24).

Ref. 3 Math functions by this flow chart.

- This flow chart is applied to the following 3 math functions.
- When the communications interface is added, the data communications input can be set with keys.

LoGE	: Natural logarithm
Log10	: Logarithm
PoWEr	: Exponential
AbS	: Absolute value
Commin	: Data communications input

Ref. 4 Programming range of max. and min. values
 Program the values within 5 digits including a sign. The remaining digits on the right side should be kept blank. For the initial programming, all digits are blank.

Ref. 5 Storing
 Store "temporarily stored" parameters by pressing **SHIFT** and **SET END** simultaneously. If not, the parameters programmed earlier remain.

3.3 Arithmetic computation 1

(Ex.) $Ax + By + Cxy + D$: To multiply the measured value 'x' of Channel 2 by 2 and print its result on Channel 2

A = 2, B = C = D = 0, x = Channel 2, y = not used, Printing range = 0.0 to 100.0

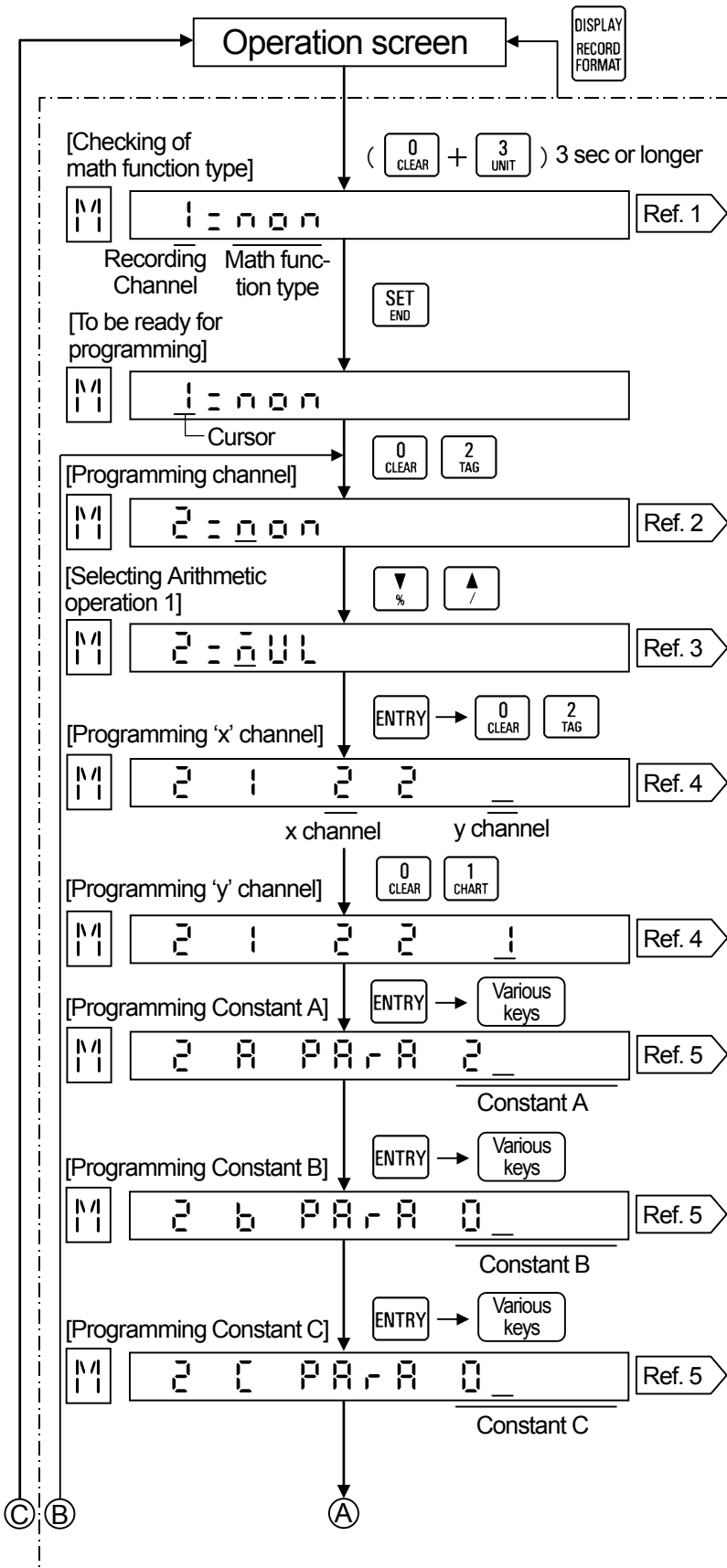

Ref. 1 Checking of other channels
You can check the math function type of other channels. Press \downarrow or \uparrow to change channels.

Ref. 2 Channel digit
In AH3000 series multi-point type, a channel is programmed by two digits (06/12/24).

Ref. 3 Math functions by this flow chart.
This flow chart is only applied to Arithmetic computation 1 (mUL).

Ref. 4 'x' and 'y' channels

1. Not-used channel
If the measured value of 'x' channel or 'y' channel is not used, make sure to program any channel number to the channel not used as a dummy input. (No programming of the channel not used will become an error.) Then program the appropriate constants to '0'.
2. For the initial programming, both 'x' and 'y' channels are blank.

Ref. 5 Constants of A, B, C and D

1. Not-used constants
For the not-used constant, program it to '0'.
2. Programming of constants
(1) 5 digits or less including a sign
(2) Down to three decimal places
Ex. $\square\square.\square\square\square$

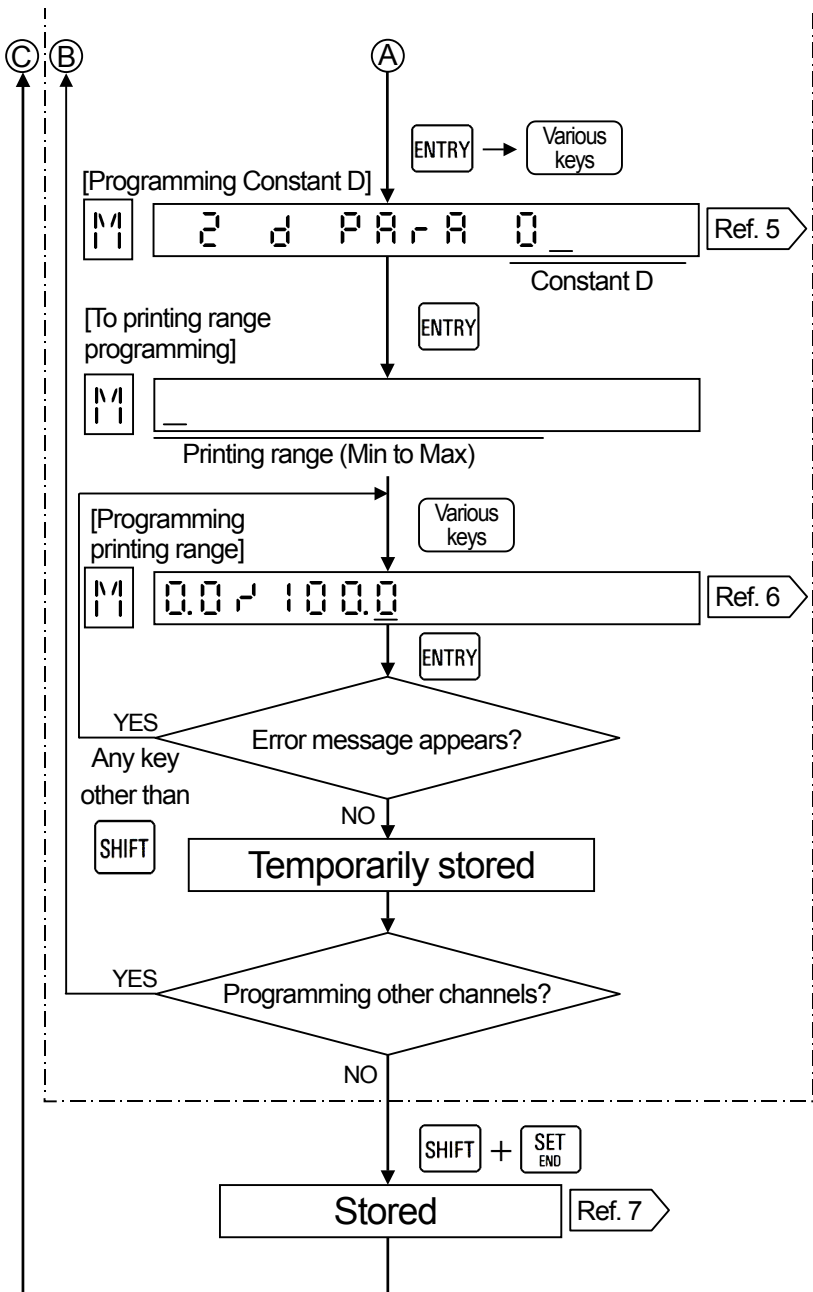

Ref. 6 Programming range of max. and min. values
 Program the values within 5 digits including a sign. The remaining digits on the right side should be kept blank. For the initial programming, all digits are blank.

Ref. 7 Storing
 Store "temporarily stored" parameters by pressing **SHIFT** and **SET END** simultaneously. If not, the parameters programmed earlier remain.

3.4 Arithmetic computation 2

(Ex.) $Ax / y + B$: To divide the measured value 'x' of Channel 2 by the measured value 'y' of Channel 1 and print its result on Channel 2

A = 1.0, B = 0, x = Channel 2, y = 1, Printing range = 0.0 to 100.0

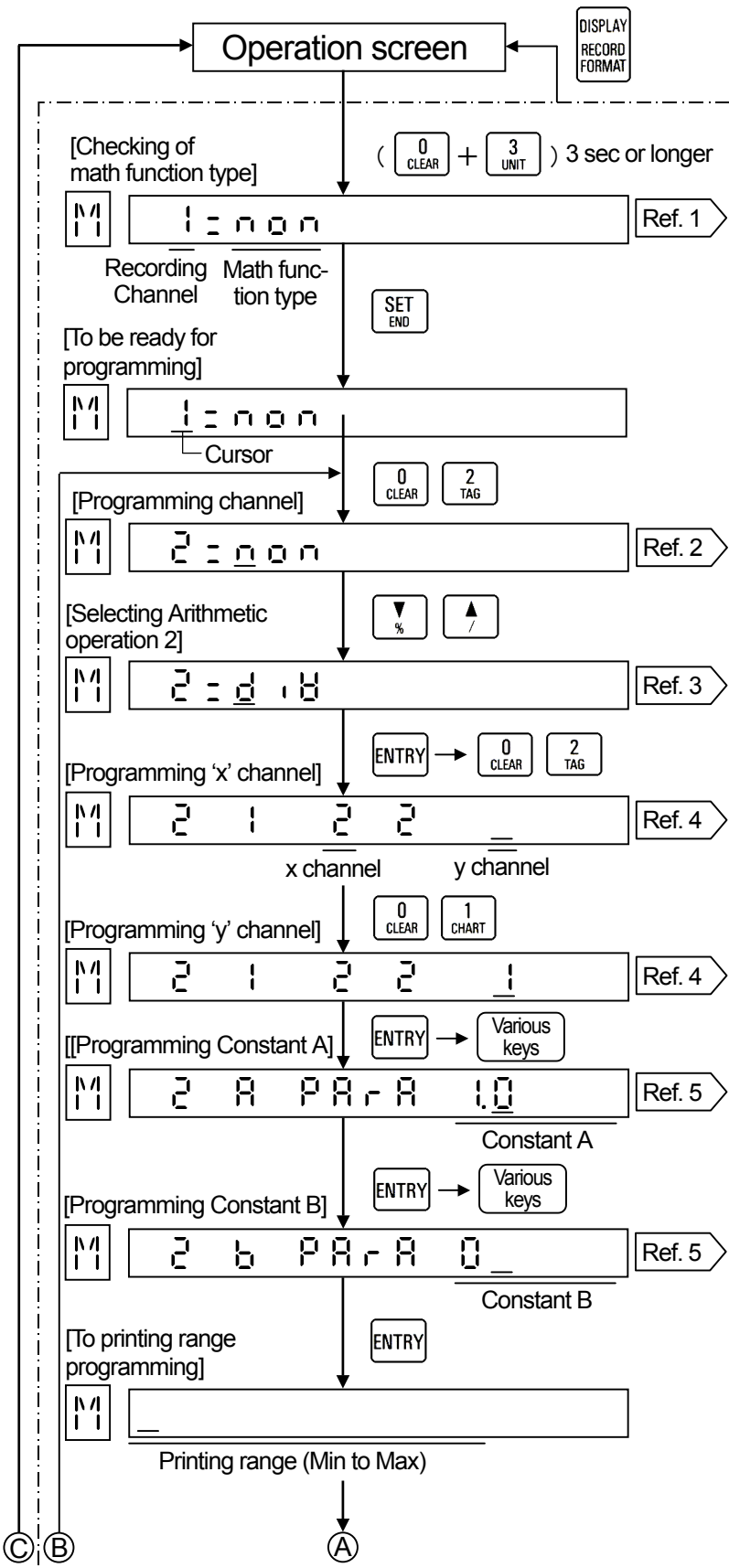

Ref. 1 Checking of other channels
 You can check the math function type of other channels. Press \downarrow or \uparrow to change channels.

Ref. 2 Channel digit
 In AH3000 series multi-point type, a channel is programmed by two digits (06/12/24).

Ref. 3 Math functions by this flow chart.
 This flow chart is only applied to Arithmetic computation 2 (diV).

Ref. 4 'x' and 'y' channels
 For the initial programming, both 'x' and 'y' channels are blank.

Ref. 5 Constants of A and B
 1. Not-used constants
 For the not-used constant (B), program it to '0'.
 2. Programming of constants
 (1) 5 digits or less including a sign
 (2) Down to three decimal places
 Ex. $\square\square.\square\square\square$

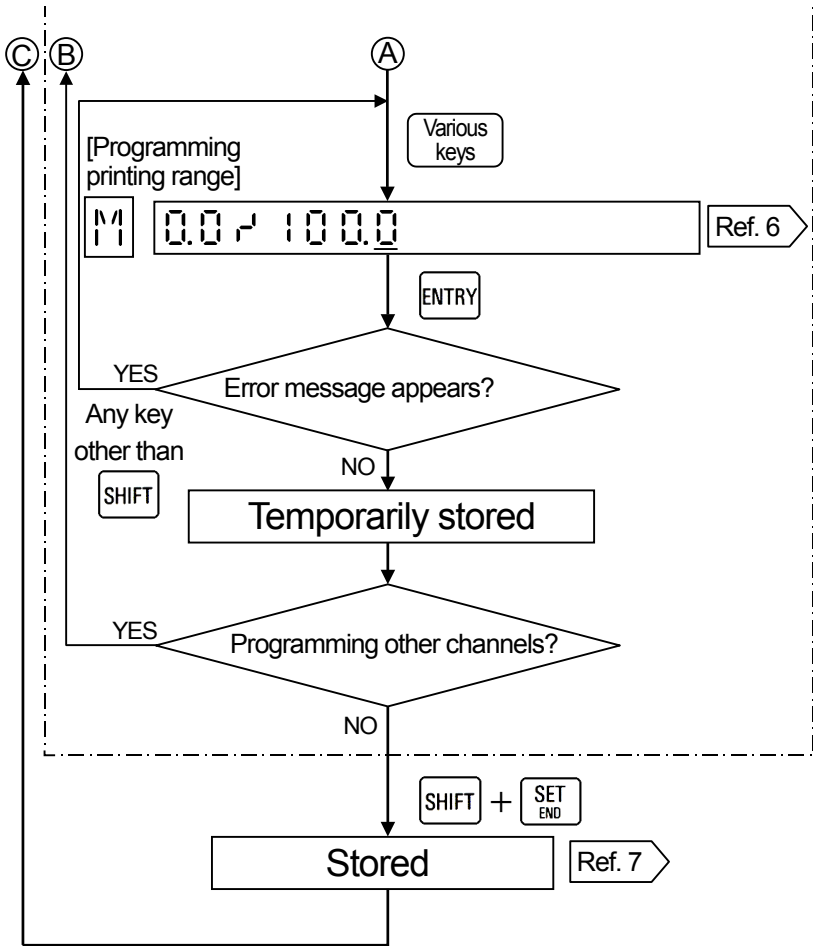

Ref. 6 Programming range of max. and min. values
 Program the values within 5 digits including a sign. The remaining digits on the right side should be kept blank. For the initial programming, all digits are blank.

Ref. 7 Storing
 Store "temporarily stored" parameters by pressing **SHIFT** and **SET END** simultaneously. If not, the parameters programmed earlier remain.

3.5 Computation of maximum, minimum and average values

(Ex.: Maximum value) To print, on Channel 3, the maximum value in the measured value of Channel 2
 A (Interval) = 30 min., B (Start time) = 08:00 am, Printing range = 0.0 to 100.0

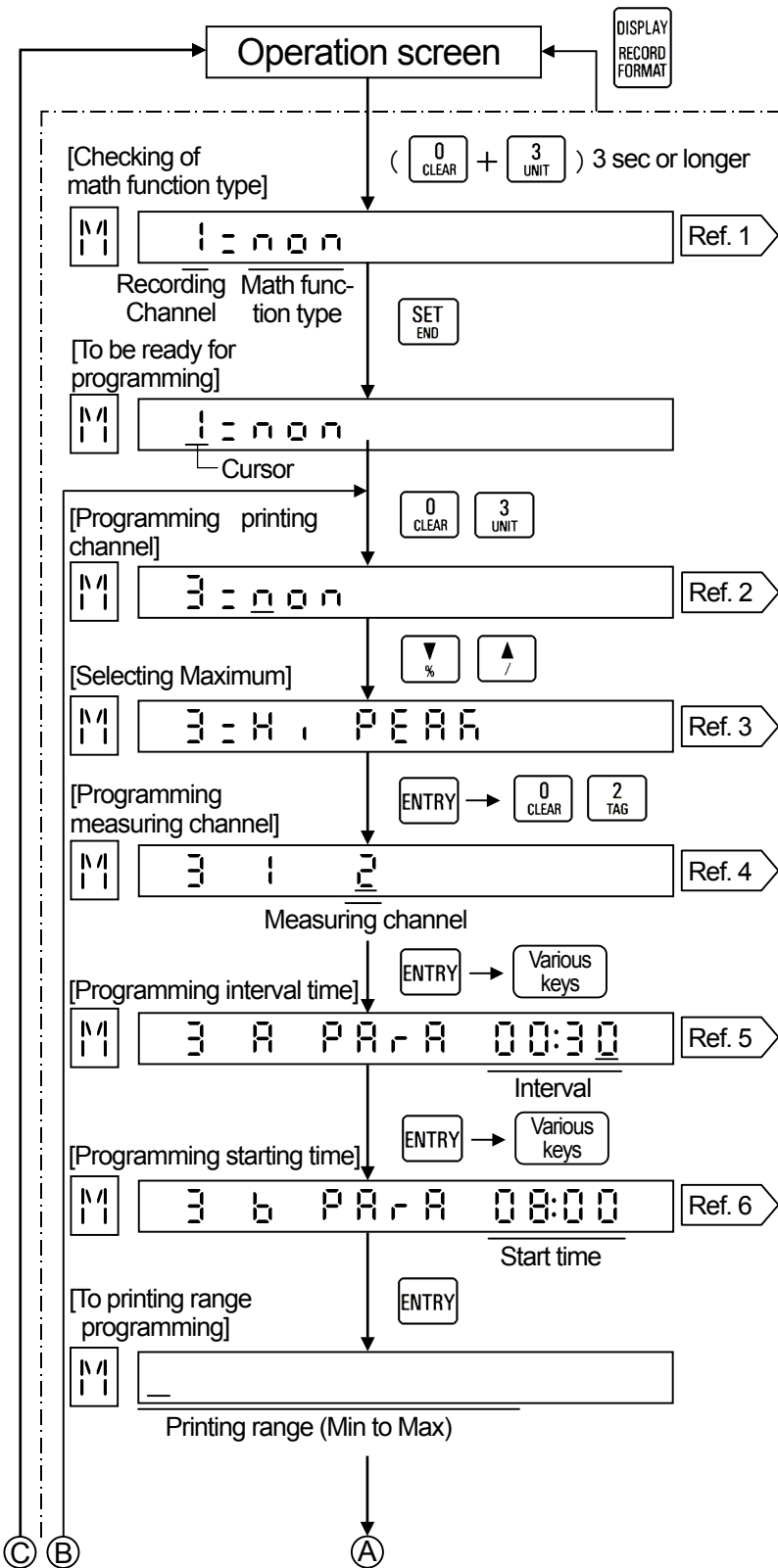

Ref. 1 Checking of other channels
 You can check the math function type of other channels. Press \downarrow or \uparrow to change channels.

Ref. 2 Channel digit
 In AH3000 series multi-point type, a channel is programmed by two digits (06/12/24).

Ref. 3 Math functions by this flow chart.
 This flow chart is applied to the following 3 math functions.

Hi PEAK	: Maximum value
Lo PEAK	: Minimum value
AVERAGE	: Average value

Ref. 4 Measuring channel
 For the initial programming, the measuring channel is blank.

Ref. 5 Programming range of interval
 00:01 to 24:00

Ref. 6 Programming range of start time
 00:00 to 23:59

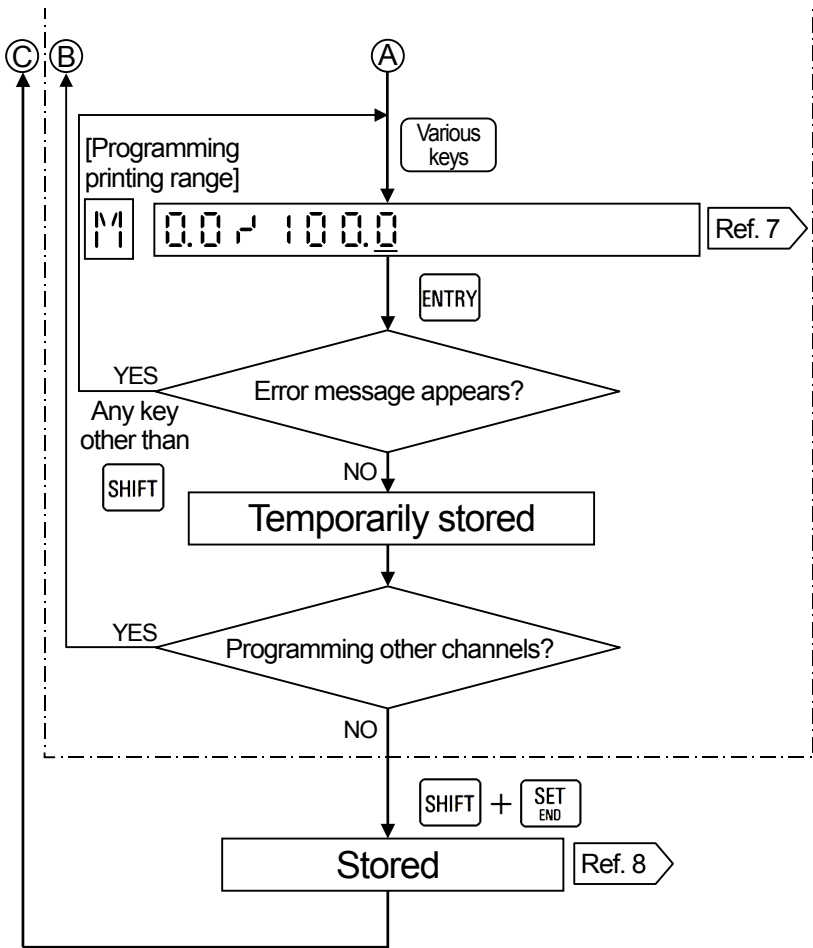

Ref. 7 Programming range of max. and min. values

Program the values within 5 digits including a sign. The remaining digits on the right side should be kept blank. For the initial programming, all digits are blank.

Ref. 8 Storing

Store "temporarily stored" parameters by pressing **SHIFT** and **SET END** simultaneously. If not, the parameters programmed earlier remain.

3.6 Computation of temperature/humidity

(Ex.) To print the humidity on Channel 2

Dry bulb (Temperature) = Channel 1, Wet bulb (Temperature) = Channel 2, Printing range = 0.0 to 100.0

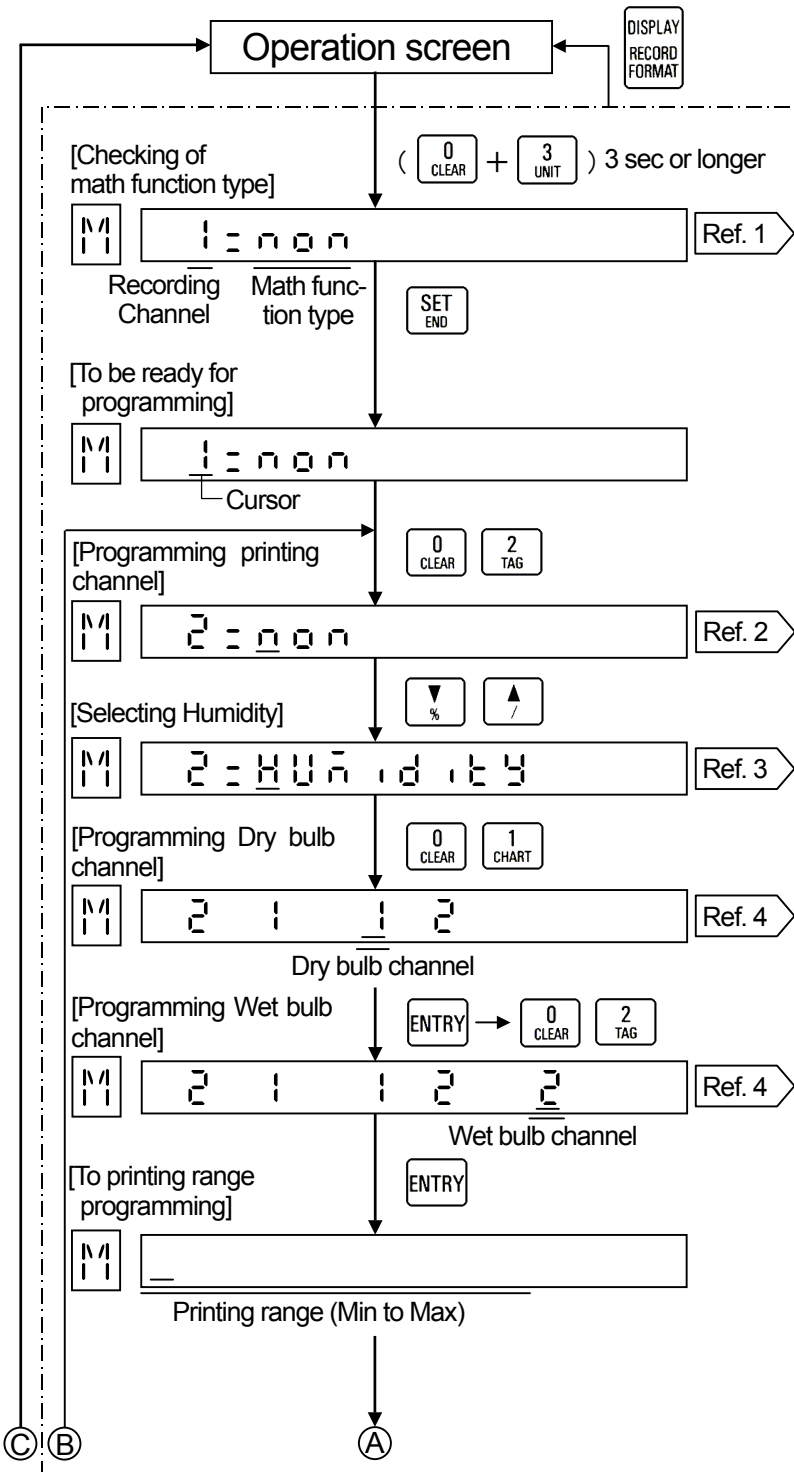

Ref. 1 Checking of other channels
 You can check the math function type of other channels. Press \downarrow or \uparrow to change channels.

Ref. 2 Channel digit
 In AH3000 series multi-point type, a channel is programmed by two digits (06/12/24).

Ref. 3 Math functions by this flow chart.
 This flow chart is only applied to Humidity computation (HUmidity).

Ref. 4 Dry and wet bulb channels
 For the initial programming, both dry bulb and wet bulb channels are blank.

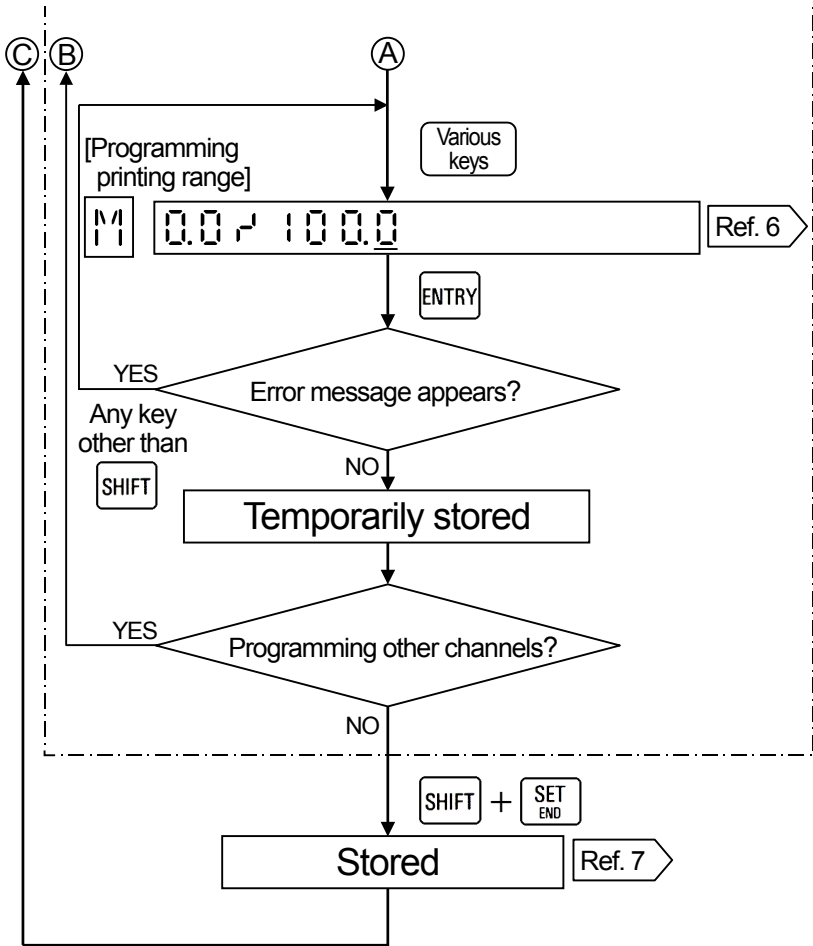

Ref. 6 Programming range of max. and min. values

Program the values within 5 digits including a sign. The remaining digits on the right side should be kept blank. For the initial programming, all digits are blank.

Ref. 7 Storing

Store "temporarily stored" parameters by pressing **SHIFT** and **SET END** simultaneously. If not, the parameters programmed earlier remain.

[2] Totalizing

The measured data of each channel can be totalized and their results are displayed and printed.
The alarm setpoints in the channel Nos. for totalized results is programmed for the totalized values.

1. Math expression for totalizing computation

$$\text{INT}_n = \text{INT}_{n-1} + \frac{(\text{PV}_n + \text{PV}_{n-1}) \times (\text{T}_n - \text{T}_{n-1})}{2} \div \text{Tbase}$$

INT_n : Totalized value	T_n : Measured time at this time
INT_{n-1} : Last totalized value	T_{n-1} : Measured time at last time
PV_n : Measured value at this time *1	Tbase : Time unit *2
PV_{n-1} : Measured value at last time *1	

*1 : If the measured value exceeds the scale range, the minimum or maximum values of scale is taken as the measured value.

*2 : This time unit is for the measured value. If the unit is in second, the value is 1. If it is in minute, the value is 60. If it is in hour, the value is 3600. The unit is selected from second, minute or hour.

(Ex.) m3/min→60, m3/h→3600

Note) Measuring interval ($\text{T}_n - \text{T}_{n-1}$)

AL3000 Multi-point type (6-point input): approx. 5 seconds

AH3000 Multi-point type (6-point input): approx. 5 seconds

AH3000 Multi-point type (12-point input): approx. 10 seconds

AH3000 Multi-point type (24-point input): approx. 20 seconds

AL3000 pen type (1 to 4 point input): approx. 0.1 second

AH3000 pen type (1 to 4 point input): approx. 0.1 second

2. Programming

2.1 Resetting of totalizing computation

1) Start and resetting of totalized value by remote contacts reset

When the optional remote contacts function is added, the totalizing computation can be started or the totalized value can be reset by the remote contacts signal.

When the totalizing computation starts by the remote contacts reset, the totalized value is reset with each programmed interval, after the start.

For multi-point type, the EX4 terminal in remote contacts terminals EX1 to EX4 is used for the resetting of totalizing computation. The list printing is only executed by using this terminal when the totalizing computation is not required. For details, refer to the separate standard manual.

2) Resetting of totalized value by the programmed intervals

The totalized value is automatically reset after the programmed interval time from the start of the totalizing computation, and then restarts.

2.2 Overflow of totalized value

The maximum totalized value is limited to the maximum value of the printing range. When this totalized value exceeds its limitation, the value is reset to 0 and then the totalizing computation continues.

2.3 Operation at power failure recovery

1. If the power is recovered in the programmed interval time, the totalizing computation continues.
2. If the power is not recovered in the programmed interval time, the totalizing computation is canceled * and starts again from the recovery time.
3. The judgment of power failure is within 24 hours. If the power failure continues longer than 24 hours, the totalizing computation is canceled irrespective the recovery time and starts again from the recovery time.
* The totalizing computation is canceled and reset.

2.4 Interval time

The programming range of the interval time is 00:01 to 24:00. If the interval time is not required (in case of resetting of the totalized value by the remote contacts reset), program it to 99:00.

2.5 Starting time of totalizing computation

The programming range of the starting time is 00:00 to 23:59. This starting time is only valid for the first operation after its setting. The totalizing computation starts from the starting time. If the starting time is not required (starting by the remote contacts signal), program it to 99:00.

2.6 Printing range

The printing range of the channel for totalized result is "Printing range" programmed by totalizing computation programming, not by range programming.

2.7 Decimal place for display and printing

The decimal place is decided by "Printing range" programmed by totalizing computation programming. If the decimal place differs in the maximum and minimum values, the fewer decimal places is effective.

3. Programming flow chart

(Ex.) To execute the totalizing computation for measured value of Channel 1 and print its result on Channel 2

Time unit = min, Totalizing interval = 1 hour, Start time = 08:00 am

Printing range for totalized value = 0 to 1000

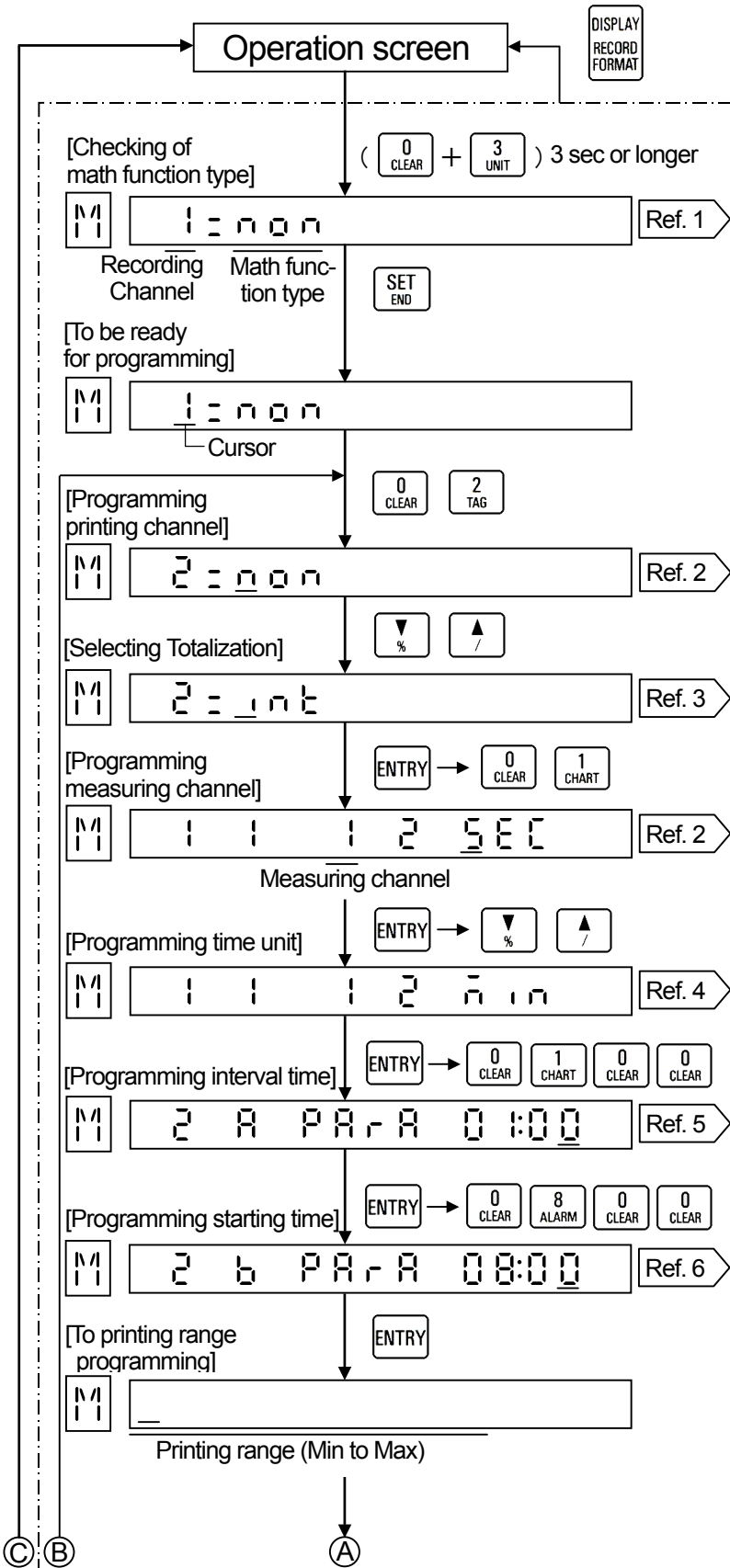

Ref. 1 Checking of other channels
 You can check the math function type of other channels. Press \downarrow or \uparrow to change channels.

Ref. 2 Channel digit
 In AH3000 series multi-point type, a channel is programmed by two digits (06/12/24).

Ref. 3 Math functions by this flow chart.
 This flow chart is only applied to Totalizing computation (int). For the combined option with math functions, various items are displayed.

Ref. 4 Time unit
 3 types of time unit (sec, min, and hour) for measured value, are available.
 (Ex.) If m^3 / min is required, select min.

Ref. 5 Programming range of interval
 00:01 to 24:00
 If the interval time is not required, program it to 99:00.

Ref. 6 Programming range of start time
 00:00 to 23:59
 If the starting time is not required, program it to 99:00.

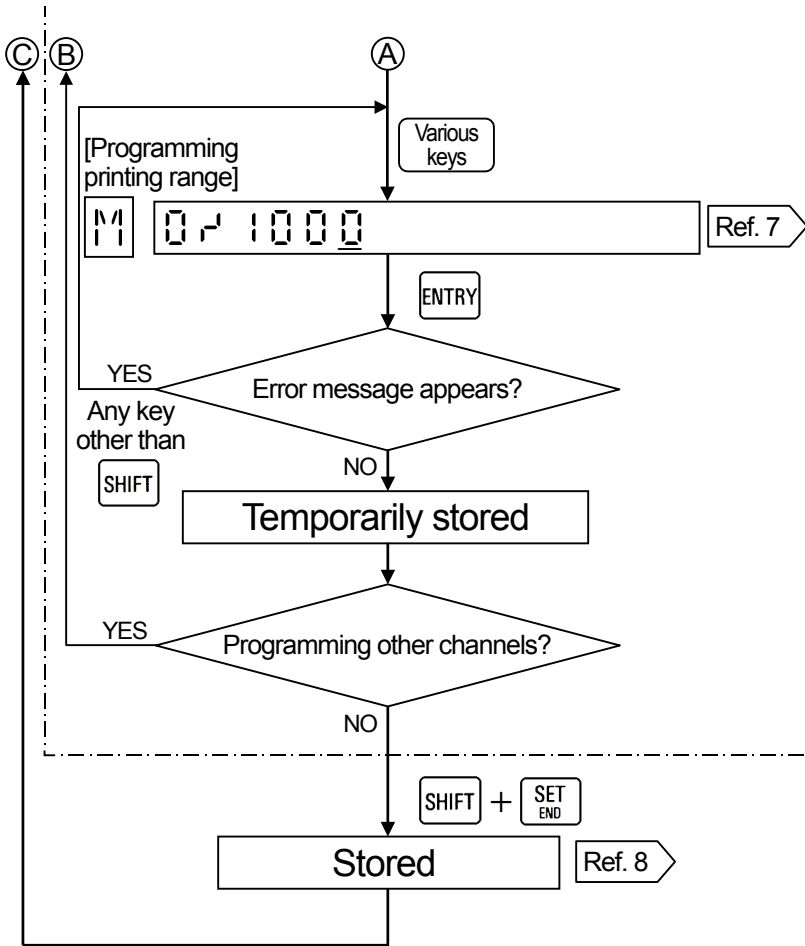

Ref. 7 Programming range of max. and min. values

Program the values within 5 digits including a sign. The remaining digits on the right side should be kept blank. For the initial programming, all digits are blank.

Ref. 8 Storing

Store "temporarily stored" parameters by pressing **SHIFT** and **SET END** simultaneously. If not, the parameters programmed earlier remain.

[3] Flow correction

1. Correction computation types and math expressions

1.1 Flow correction computation 1 (FLoW1):

Volume correction of gas (ideal gas)

$$A \cdot X \cdot (E + B) / (C \cdot (F + D))$$

A, B, C, D: Constants
E, F: Arbitrary channels
X: Measuring channel

(Basic formula)

$$Q_n = Q_i \times \frac{T_n}{T_i} \times \frac{P_i}{P_n} \times \frac{Z_n}{Z_i}$$

Q_n : Corrected result
 T_n : Reference temperature
 P_n : Reference pressure
 Z_n : Compression coefficient of measured fluid at reference temperature (T_n) and reference pressure (P_n).
 Z_i : Compression coefficient of measured fluid at measurement condition

Q_i : Volumetric flow rate at measurement condition of flow meter
 T_i : Temperature of measured fluid at measurement condition
 P_i : Pressure of measured fluid at measurement condition

1.2 Flow correction computation 2 (FloW2):

Volume correction of liquid (excluding petroleum)

$$X \cdot (1 - A \cdot (E - B)) \cdot (1 + C \cdot (F - D))$$

A, B, C, D: Constants
E, F: Arbitrary channels
X: Measuring channel

(Basic formula)

$$Q_n = Q_i \cdot (1 - \alpha \cdot (T_i - T_n)) \cdot (1 + \beta \cdot (P_i - P_n))$$

Q_n : Corrected result
 T_n : Reference temperature
 P_n : Reference pressure
 α : Cubic expansion coefficient of measured fluid
 β : Compressibility of measured fluid.

Q_i : Volumetric flow rate at measurement condition of flow meter
 T_i : Temperature of measured fluid at measurement condition
 P_i : Pressure of measured fluid at measurement condition

1.3 Flow correction computation 3 (FloW3):

Volume correction of liquid (petroleum)

$$E \cdot \exp(A \cdot (F - B) + C \cdot (F - B)^2)$$

A, B, C: Constants
E, F: Arbitrary channels

(Basic formula)

$$Q_n = Q_i \cdot \exp(-\alpha_t \cdot \Delta t \cdot (1.0 + 0.8\alpha_t \cdot \Delta t))$$

$$\alpha_t = \frac{K0}{(\rho_{15})^2} \times \frac{K1}{\rho_{15}}$$

Q_n : Corrected result
 Q_i : Volumetric flow rate at measurement condition of flow meter
 ρ_{15} : Density (15°C) [kg/m³]
K0, K1 : Constants

α_t : Thermal expansion coefficient at 15°C [°C⁻¹]
 Δt : Temperature difference [$t = T_i - 15$] [°C]

1.4 Flow correction computation 4 (FloW3):

Square root computation of flow correction 1

$$\sqrt{A \cdot X \cdot (E+B) / C \cdot (F+D)}$$

A, B, C, D: Constants
E, F: Arbitrary channels
X: Measuring channel

1.5 Flow correction computation 5 (FloW5):

Temperature/pressure correction of differential pressure type flow meter (ideal gas)

$$A \cdot X \cdot \sqrt{(B \cdot E + C) / (D \cdot F + 273.15)}$$

A, B, C, D: Constants
E, F: Arbitrary channels
X: Measuring channel

(Basic formula)

$$Q_d = Q_f \cdot \sqrt{\frac{P_f}{P_d}} \cdot \sqrt{\frac{T_d}{T_f}}$$

Q_d : Corrected result

Q_f : Flow rate at measurement condition.

P_d : Reference pressure

T_d : Reference temperature

P_f : Pressure of measured fluid at measurement condition

T_f : Temperature of measured fluid at measurement condition

1.6 Flow correction computation 6 (FloW6):

Temperature correction of differential pressure type flow meter (ideal gas)

$$(A \cdot E + B) / \sqrt{C \cdot F + D}$$

A, B, C, D: Constants
E, F: Arbitrary channels

1.7 Flow correction computation 7 (FloW7):

Pressure correction of differential pressure type flow meter (ideal gas)

$$(A \cdot E + B) \cdot \sqrt{C \cdot F + D}$$

A, B, C, D: Constants
E, F: Arbitrary channels

2. Programming

2.1 Printing range

The printing range of the channel for flow correction computed result is "Printing range" programmed by flow correction computation programming, not by range programming.

2.2 Decimal place for display and printing

The decimal place is decided by "Printing range" programmed by flow correction computation programming. If the decimal place differs in the maximum and minimum values, the fewer decimal places is effective.

2.3 Abnormal data

1. When the data of each channel is abnormal (over-range, under-range, burnout, without range programming) or a denominator becomes zero (0), the flow correction computed result is treated as under-range.
2. The flow rate input before correction is computed with the limitation at 0.

memo

3. Programming flow chart

(Ex.) Flow correction 1: $A \cdot X \cdot (E + B) / (C \cdot (F + D))$

A = D = 273.15, B = 0, C = 1, E = Channel 3 (pressure input)

F = Channel 4 (temperature input), X = Channel 2 (flow input), Printing range = 0.0 to 100.0

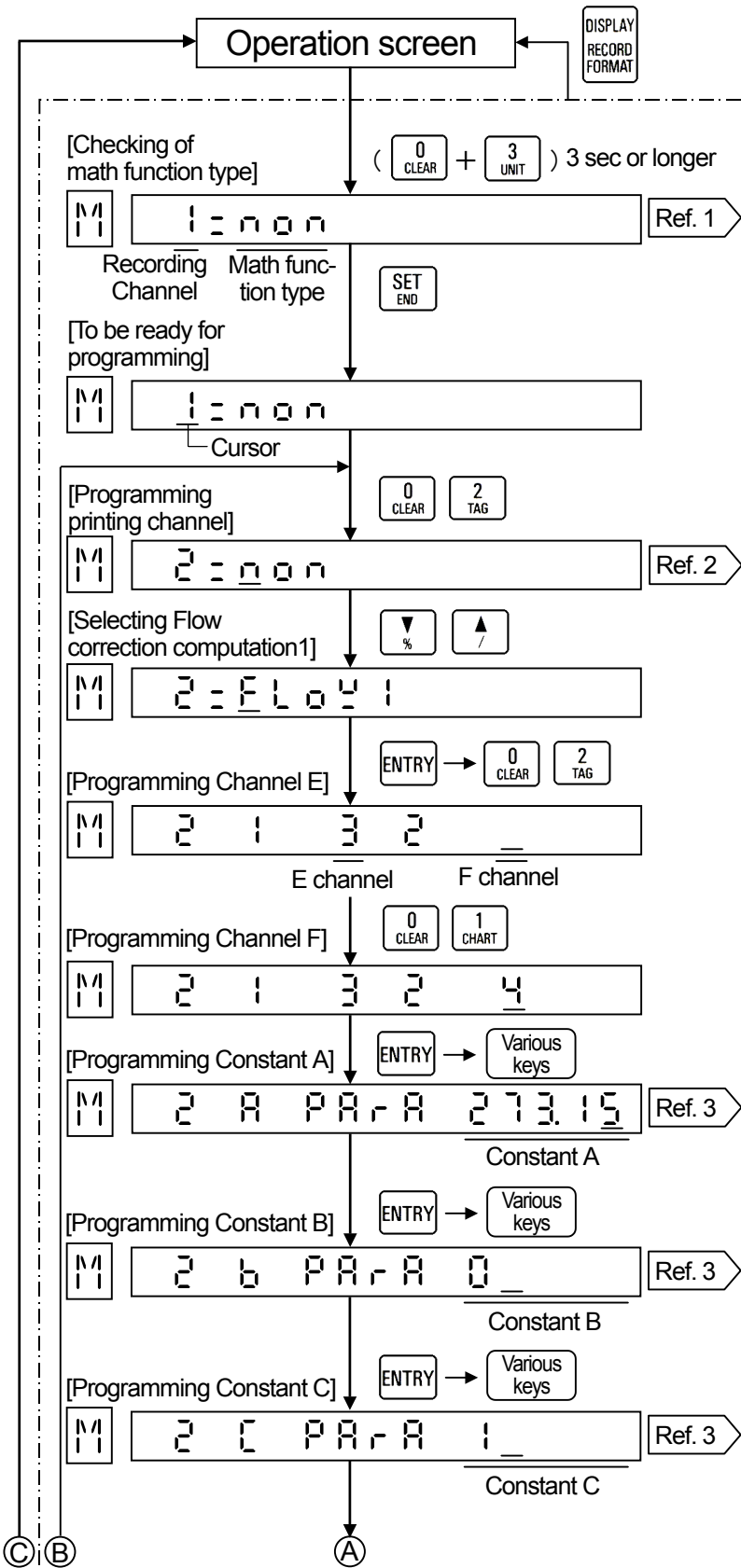

Ref. 1 Checking of other channels
 You can check the math function type of other channels.
 Press \downarrow or \uparrow to change channels.

Ref. 2 Channel digit
 In AH3000 series multi-point type, a channel is programmed by two digits (06/12/24).

Ref. 3 Constants of A, B, C and D
 1. Not-used constants
 For the not-used constant (B), program it to '0'.
 2. Programming of constants
 (1) 5 digits or less including a sign
 (2) Down to three decimal places
 Ex. $\square\square.\square\square\square$
 3. For FLOW3, the constant D is not existed.

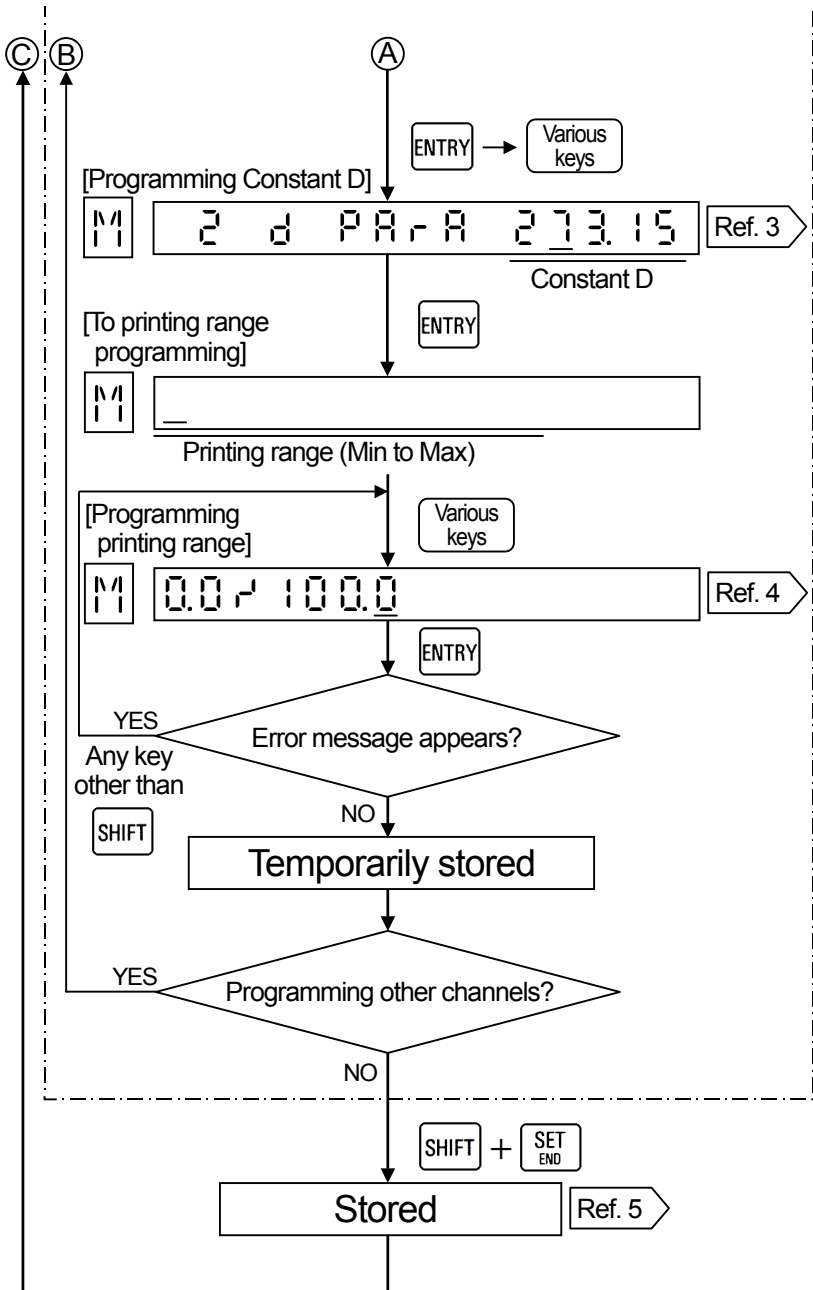

Ref. 4 Programming range of max. and min. values

Program the values within 5 digits including a sign. The remaining digits on the right side should be kept blank. For the initial programming, all digits are blank.

Ref. 5 Storing

Store "temporarily stored" parameters by pressing **SHIFT** and **SET END** simultaneously. If not, the parameters programmed earlier remain.

[4] List printing

If the channels that math computation, totalizing computation or flow correction computation is programmed exist, a list of these computations is printed after the scale printing (including engineering unit and tag).

[Example of list print]

CH	MATH	RECORD	PARAMETERS	
1	MUL	0.0~100.0	E:1 F:2	← Arithmetic computation 1
	A: 2, B: 0, C: 0, D: 0			
2	DIV	0.0~100.0	E:2 F:3	← Arithmetic computation 2
	A:2, B:1.5			
3	LOGE	0.00~100.00		← Natural logarithm computation
4	LOG10	0.0~200.0		← Logarithm computation
5	POWER	0.0~50.0		← Exponential computation
6	ROOT	0.0~100.0		← Square root computation
2	HUMID	0.0~100.0	E:1 F:2	← Temperature/humidity computation
3	H-PEAK	0~1000	E:3	← Maximum value computation
	A: 01:00, B: 08:00			
4	L-PEAK	-100.0~100.0	E:4	← Minimum value computation
	A: 00:30, B:12:00			
5	AVE	0.00~100.00	E:5	← Average value computation
	A: 01:00, B: 06:30			
6	ABS	0.00~100.00		←Absolute value computation
1	INT	0.0~1000.0	E:1 F:M	← Totalizing computation
	A: 00:30, B: 08:00			
2	COMM	0.0~1000.0		← Data communications input
1	FLOW1	0.0~100.0	E:2 F:03	←Flow correction computation 1
	A: 273.15, B: 0, C: 1, D: 273.15			

[Remark 1]

The above example is for AL3000.

For AH3000, Arithmetic computation 1, Arithmetic computation 2, Maximum value computation, Minimum value computation, Average value computation and Totalizing computation are printed in a single line.

[Remark 2]

Parameters E and F

E is for x channel and F is for y channel.

For the totalizing computation, E is for a measuring channel and F is for a time unit.

[Remark3]

The printing format for FLoW2 to FLoW7 is same as FLoW1.

For FLoW3, the constant D is not printed because it does not exist.

[Appendix] Conversion table for temperature/humidity computation

(By Sprung formula)

$\frac{\Delta\theta}{\theta_w}$	0.0	0.2	0.4	0.6	0.8	1.0	1.2	1.4	1.6	1.8	2.0	2.2	2.4	2.6	2.8	3.0	3.5	4.0	4.5	5.0	5.5	6.0	6.5	7	8	9	10	11	12	13	14
40	100	99	98	96	95	94	93	92	91	89	88	87	86	85	84	83	81	78	76	73	71	69	67	65	61	57	54	51	48	45	43
38	100	99	97	96	95	94	93	91	90	89	88	87	86	85	84	83	80	78	75	73	71	68	66	64	60	56	53	50	47	44	42
36	100	99	97	96	95	94	92	91	90	89	88	87	85	84	83	82	79	77	74	72	70	67	65	63	59	56	52	49	46	43	41
34	100	99	97	96	95	93	92	91	90	88	87	86	85	84	83	82	79	76	74	71	69	67	64	62	58	55	51	48	44	42	39
32	100	99	97	96	95	93	92	91	89	88	87	86	84	83	82	81	78	76	73	70	68	66	63	61	57	53	50	46	43	41	38
30	100	99	97	96	94	93	92	90	89	88	86	85	84	83	82	80	77	75	72	69	67	65	62	60	56	52	48	45	42	39	36
28	100	99	97	96	94	93	91	90	89	87	86	85	83	82	81	80	77	74	71	68	66	63	61	59	55	51	47	43	40	37	35
26	100	98	97	95	94	92	91	90	88	87	85	84	83	81	80	79	76	73	70	67	65	62	60	57	53	49	45	42	39	36	33
24	100	98	97	95	94	92	91	89	88	86	85	83	82	81	79	78	75	72	69	66	63	61	58	56	51	47	43	40	37	34	31
22	100	98	97	95	93	92	90	89	87	86	84	83	81	80	78	77	74	71	68	65	62	59	57	54	50	45	41	38	35	31	29
20	100	98	96	95	93	91	90	88	86	85	83	82	80	79	77	76	73	69	66	63	60	58	55	52	48	43	39	35	32	29	26
18	100	98	96	94	93	91	89	87	86	84	83	81	79	78	76	75	71	68	65	62	59	56	53	50	45	41	37	33	30	27	24
16	100	98	96	94	92	90	89	87	85	83	82	80	78	77	75	74	70	66	63	60	57	54	51	48	43	38	34	30	27	24	21
14	100	98	96	94	92	90	88	86	84	82	81	79	77	75	74	72	68	64	61	57	54	51	48	45	40	35	31	27	24	20	17
12	100	98	96	93	91	89	87	85	83	81	79	77	76	74	72	70	66	62	59	55	52	48	45	42	37	32	28	24	20	17	14
10	100	98	95	93	91	88	86	84	82	80	78	76	74	72	70	69	64	60	56	52	49	45	42	39	33	28	24	20	16	13	10
8	100	97	95	92	90	88	85	83	81	79	76	74	72	70	68	66	62	57	53	49	46	42	39	35	29	24	19	15	11		
6	100	97	94	92	89	87	84	82	79	77	75	72	70	68	66	64	59	54	50	46	42	38	34	31	25	19	15	10			
4	100	97	94	91	88	86	83	80	78	75	73	70	68	66	63	61	56	51	46	42	37	33	30	26	20	14					
2	100	97	93	91	87	84	81	78	76	73	70	68	65	63	60	58	52	47	42	37	33	28	24	21	14						
0	100	96	93	89	86	83	80	76	73	70	67	65	62	59	57	54	48	42	37	31	27	22	18	14							
-2	100	96	92	88	85	81	78	74	71	68	64	61	58	55	52	50	43	37	31	25	20	15	11								
-4	100	95	91	87	83	79	75	71	68	64	61	57	54	51	48	45	37	30	24	18	13										
-6	100	95	90	86	81	77	72	68	64	60	56	53	49	45	42	39	30	23	16	10											
-8	100	95	89	84	79	74	69	64	60	56	51	47	43	39	35	32	23	14													
-10	100	94	88	82	76	71	65	60	55	50	45	40	36	32	27	23	13														

$\Delta\theta$: Temperature difference between dry bulb and wet bulb θ_w : Temperature of wet bulb (°C)

CHINO

CHINO CORPORATION

32-8, KUMANO-CHO, ITABASHI-KU, TOKYO 173-8632

Telephone: 81-3-3956-2171

Facsimile: 81-3-3956-0915

