

Infrared Multi Analyzer IM series



10-wavelength, 4-constituent, High-speed/High-repeatability, Multi-interface, Easy to operate

The IM series is an on-line multi IR wavelength analyzer utilizing the infrared absorption technology for measuring product constituent and/or thickness. Signal processing capabilities are built into the Compact All-In-One detector unit for easy installation and operation. A maximum of 99 calibration curves can be stored into the detector memory for numerous measurement applications. The detector can be used by itself or connected to a PC/plant control system, as both analog and digital outputs are provided. A remote setting display unit, connectable up to 9 detector units, can be used to setup various detector functions and also displays measured values.

■ FEATURES

- Up to 10 wavelengths, capable of measuring 4 constituents such as; moisture, film-thickness, organism, and coating-thickness in real time simultaneously.
- Connectivity to multiple interfaces, RS485 (MODBUS), Ethernet (LAN)
- High-speed & High-repeatability (28ms)
- Multi-calculation function
- Self-diagnostic function, easy maintenance.
- Conforms to CE standards and IP-65

■ CONFIGURATION

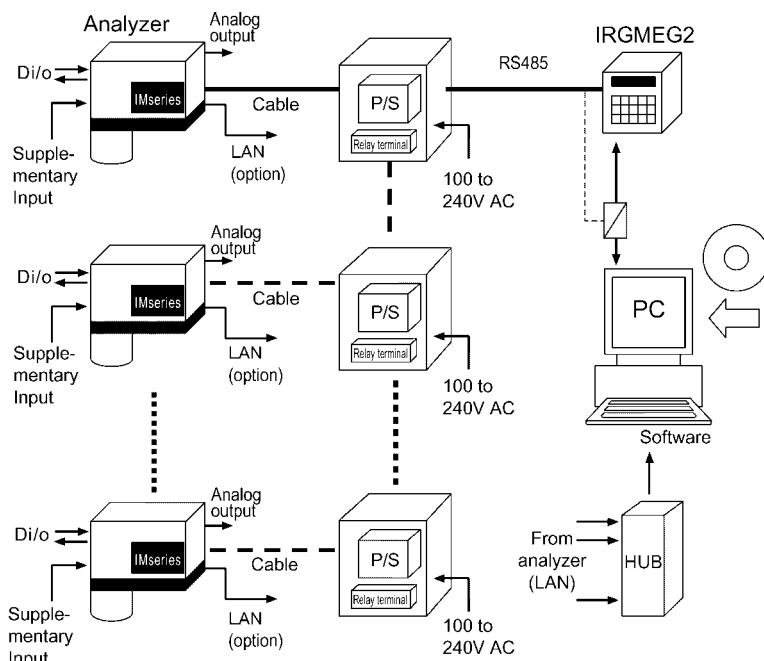

Mirror type



Fiber type

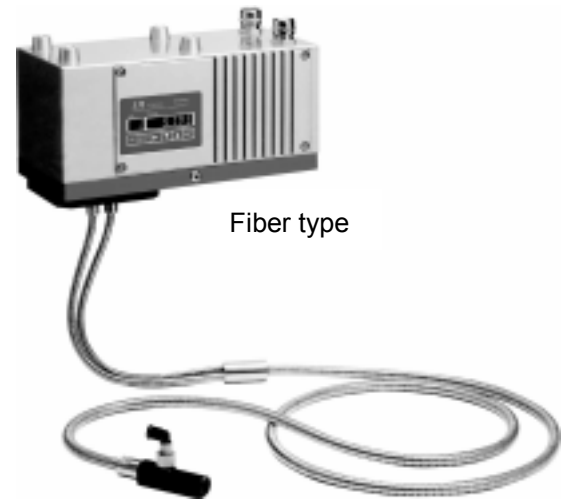

■ APPLICATION

- Measuring moisture of wood chip.
- Measuring the thickness of sheet or film.
- Measuring the organism, moisture and lipid of fodder.
- Measuring the organism, moisture and oil of potato chips.
- Measuring moisture of garbage (RDF moisture).
- Measuring the coating thickness on the painting sheet.
- Measuring moisture of powder.
- Measuring moisture in cleaning solution.
- Measuring moisture of clay.
- Measuring moisture of fiber.
- Measure & Control the coating thickness of Laminate-sheet production line.
- Measure & Control the painting thickness.

■ GENERAL SPECIFICATIONS

● INFRARED MULTI ANALYZER

Measuring system:	Infrared absorption type
Measuring wavelength:	Up to 10 wavelengths
Measuring component:	Up to 4 constituents
Light source:	Tungsten lamp
Measuring distance:	200 to 400mm (IRMA1300: 160 to 300mm)
Measuring diameter:	50mm□/300mm (IRMA1300:30mm□/200mm)
Analog output:	4 to 20mADC, ±0.2% of full scale (Load resistance: less than 500Ω)
Communications:	RS485 MODBUS
Output renewal cycle:	28ms
Display & setup:	Displays data & setup parameter Parameters are configurable by key.
Computing:	2 or 3-color ratio calculation Multiple regression calculation
No. of calibration curve:	Up to 99 curves
Calibration curve:	Linear, quadratic, cubic & multiple regression line
Calibration curve correction:	Linear & quadratic co
Smoothing (delay):	0 to 99 seconds
Calibration:	By checking plate
Detector No. setup:	When multiple detector operation, detector No. is key configurable.
Channel No. setup:	Calibration curve No. is key configurable.
Self-diagnostic:	Outputs contact signal and communications when abnormal conditions.
Correction input:	Compensate measured value by external 4 to 20mA DC (sample temperature, etc.)
External Di/o:	Di(contact input) --- Perform either one of preset, data-hold or real/smoothing Do(contact output) --- Selects self -diagnostic(1b) or Hi/low alarm(1a)
Working temperature:	0 to 50°C (Use dry air cooling if higher than 45°C. Outlet air temperature must be lower than 30°C.)
Power supply:	24V DC supplied from IR-WEP (IR-WEP power supply: 100-240VAC)
Power consumption:	Approx. 30VA
Connection:	Terminal connection
Casing:	Aluminum casting, drip-proof structure (conforming to IEC529, IP65)
Weight:	Approx. 4.3kg
Mounting:	Bolt suspension method with 4 pieces of M8 bolts
CE-standards:	EMC directives EN61326+A

■ SPECIAL SPECIFICATIONS

Specifications	Content
Small diameter	Mirror reflection type 30mm□
Rust prevention	For inside printed-circuit board
Gain specification	Special sample * Judged by sample test
P polarized light	Thin-film sample * Judged by sample test

● SETTING DISPLAY UNIT

Input signal:	RS485, Up to 9 detectors connectable
Analog output:	4 to 20mADC, 2 output* (Load resistance: less than 500Ω) * When multiple detector operation, outputs for detector No. 1 & 2.
Communications:	RS232C, RS422A or RS485 (to be specified)
Output renewal cycle:	28ms × detector number
Display:	1) Measured data, LED 5-digit 2) Detector No., CH. No., Parameter setup
Detector No. setup:	Detector No.1 to No.9 is key configurable.
Calibration curve No. setup:	Calibration curve No. is key configurable.
Smoothing time:	T = 0.0-9.9, 10-99 seconds
Calibration:	Perform calibration by key operation or by external contact in use of checking plate
Hold/preset:	Hold or preset the display and output by key operation or external contact.
Calibration curve correction:	Online correction of calibration curve Linear or quadratic correction.
External setup:	Detector No., CH. No., Calibration, Hold or Preset.
Alarm function:	Outputs contact signal (HCL) beyond setting-range
Self-diagnostic:	Outputs contact signal(1b) when abnormal condition With lamp display
Power supply:	100 to 240V AC 50/60Hz
Power consumption:	Max. 15VA
Working ambient:	0 to 50°C
Casing:	ABS resin (IP65)
Mounting:	Panel-mount type
Weight:	Approx. 0.6kg

● CE STANDARDS SPECIFICATIONS

Analog output:	4 to 20mADC, 1 output (Load resistance: less than 500Ω)
Power supply:	24V DC (within ±10%)
Power consumption:	About 10VA

● FIBER UNIT

Measuring distance and diameter:	With lens --- φ25/25mm to φ40/100mm Without lens --- φ20/15mm to φ50/50mm
Fiber length:	Standard 1.5m, Max.5m (Reflection type fiber) Standard 2m, Max.10m (Transmission type fiber)
Fiber protection:	Stainless steel flexible armour
Minimum bending radius:	R100mm
Working temperature:	0 to 150°C
Purge air flow:	With lens --- Air purge disabled Without lens --- 5 to 20L/min
Accessory:	Vertical mounting holder Flange holder

