

COMPACT INFRARED THERMOMETER IR-BZ series



*Small and high-speed separated detector,
resistant to heat, suitable for built-in system!*

IR-BZ has separated detector and main unit to make the detector smaller and can be used at high temperature condition.

Main unit has digital temperature displays and parameter setting function.

Enables long stable measurement at affordable price.



FEATURES

- High accuracy and stable measurement even the environment temperature changes.
- High speed response time 15ms, corresponds to production line requiring quick tracking.
- Wide range temperature range from low to high temperature (0 to 1000 °C)

MODELS

- IR-BZPHGE □
- Detector cable length
- 1 : 1.5m
 - 3 : 3m
 - 8 : 8m*1
 - F : 15m*1

*1 CE Marking non-approved

CONFIGURATION

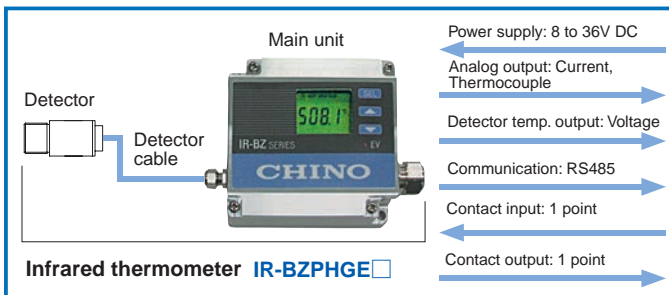

APPLICATIONS

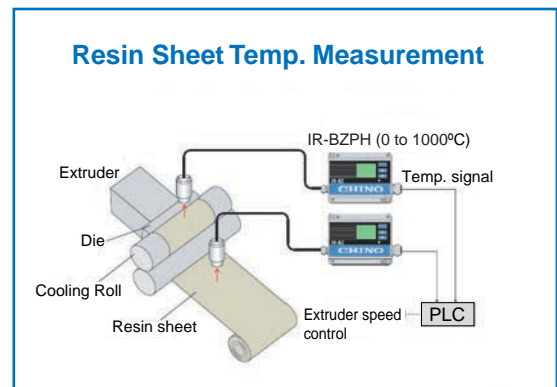
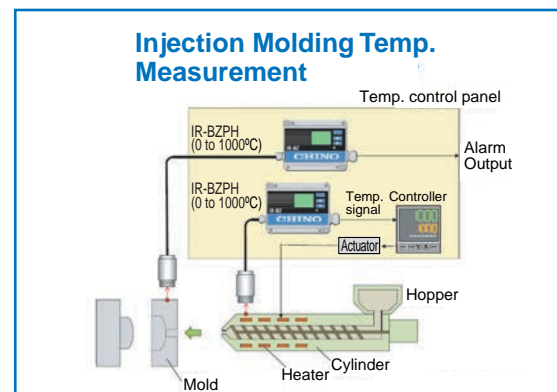
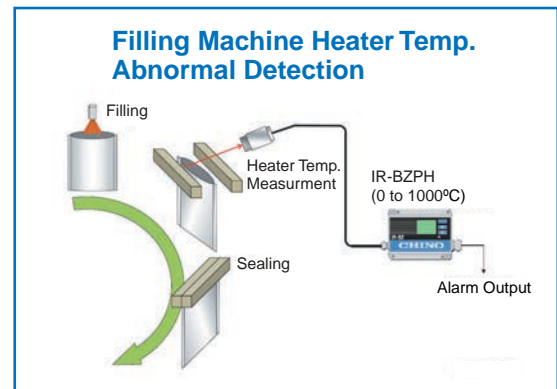

GENERAL SPECIFICATIONS

Model	IR-BZPTGN
Measuring range	0 to 1000°C
Element	Thermopile
Measuring wavelength	8 to 14μm
Accuracy rating	Accuracy rating *1 Below 20 °C : ±2 °C 20 °C to below 100 °C : ±1 °C 100 °C or above : ±1% of measuring value
Response time	15ms
Emissivity adjustment	1.999 to 0.100
Measuring diameter	φ8mm/200mm
Working temperature	Detector: -20 to 100 °C Main unit: -10 to 65 °C
Analog output	Output 1: Measured temp. value (select below by main unit) Current output 0 to 20mA DC/ 4 to 20mA DC T/C output J/K/R/S Output 2: Detector temp. 0 to 5 V/ -20 to 180 °C
Contact input/output	Contact input: 1 point, sample hold/reset Contact output: 1 point, high/low alarm, self-diagnosis (open collector)
Serial communication	RS485 (MODBUS)
Power supply	8 to 36V DC
Detector cable	Length 1.5m/3m/8m/15 (wire part) *2 OD: φ3.3mm Covering: Fluorine resin
CE Marking	EMC directive --- EN61326-1 Class A (except IR-BZPHGN8, IR-BZPHGNF) Conformity requirements --- Use of power supply for IR-BZ exclusive use and the connecting cable up to 30m (indoor use).

*1 Based on reference operation condition 23 °C ±5 °C,
ε=1.0, factory default inspection result.

*2 Please specify the detector cable length. Detector cable cannot be removed.

MEASURING DIAMETER & DISTANCE

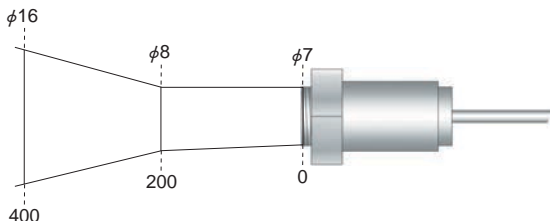

*Measuring diameter is at 90% energy response.
Please make sure that the object size should be 1.5 times larger than
measuring diameter.

EXTERNAL DIMENSIONS

Infrared thermometer

Detector

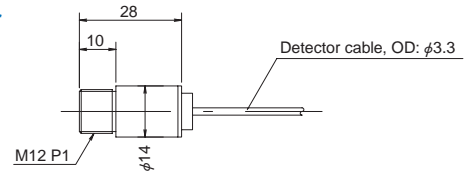

Main unit

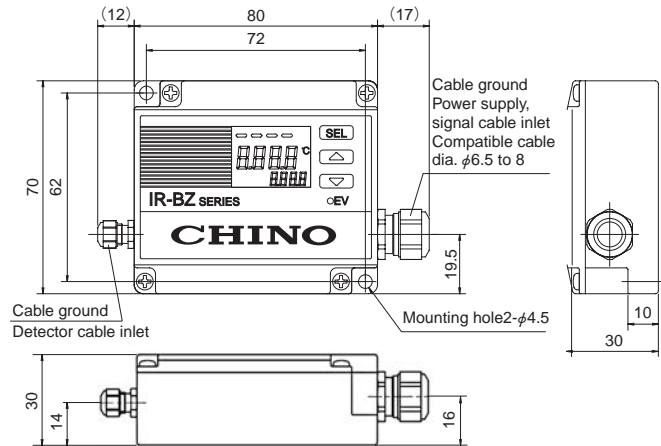

Mounting bracket

IR-ZBMP

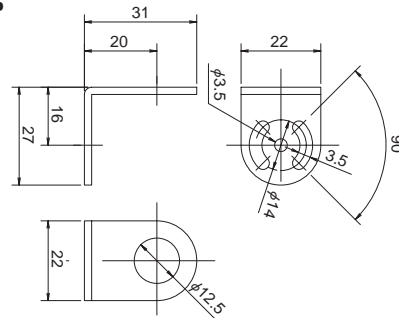

Connecting cable

IR-ZBRP□□□ (select 2m or 5m)

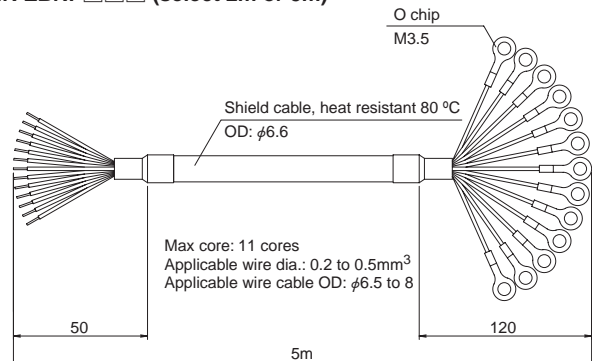

Unit: mm

Specifications subject to change without notice. Printed in Japan (I) 2017. 2

CHINO CORPORATION

32-8 KUMANO-CHO, ITABASHI-KU, TOKYO 173-8632
Telephone : +81-3-3956-2171
Facsimile : +81-3-3956-0915
E-mail : inter@chino.co.jp
Website : www.chino.co.jp/