

BR SERIES GRAPHIC RECORDERS



The BR series graphic recorders display the measured data on a 5.5" TFT color LCD display, store them into the internal flash memory and also save them into a 3.5" floppy disk or ATA flash memory card.

You can export electronic data to popular spreadsheet software by using the data acquisition software package [KIDS] or the data conversion software attached to the parameter programming software package [PASS]. General serial communications using MODBUS protocol and the Ethernet is available for the high-order communications for easy configuration of a system network with your personal computer.



■ FEATURES

● 12-point measurement in 144 x 144mm size

The measurement of 12 points is possible by utilizing the semiconductor relay, featuring high-speed, long-life and silent, for input switching. The measuring cycle for 12 points is 2 seconds.

DC voltage inputs, thermocouple inputs and resistance thermometer inputs can be freely selected in each of 12 points.

● Wide range of display functions

Points can be classified into maximum 5 groups and a trend screen, a data screen, a bargraph screen or a multi-screen can be displayed for each group. A historical trend screen, a real-time/historical trends-screen (dual trend) or an alarm summary screen can be displayed, too. A functional jog dial allows quick selection of screens.

● Storage of measured data

The measured data (maximum 1,690,000 data) are stored in the 3MB internal memory by 6 kinds of storage mode. The measured data can be copied from the internal memory to a 3.5" floppy disk or memory card (maximum 96MB). Message and alarm summary can be stored up to 200 data each.

● Easy processing of measured data

Various kinds of screen make management and processing of the measured data easy. The historical data, which have been stored in the internal memory or saved in the floppy disk, can be displayed and compared. A search function of the specified data is provided.

● Communications (option)

General serial communications of RS-232C, RS-422A or RS-485 using the MODBUS protocol and the Ethernet, being the most popular standard for LAN, are available for easy configuration of a system network with your personal computer.

● Safety Standards

The BR recorder is conformed to CE, UL, and CSA. The door and bezel are protected. (IP54)

● Functions for data reliability

For storage and management of data, protection function by password, limiting function by operators' access, and error message display function on replaying the data falsified are built in.

● Easy settings

The interactive system on the window opened by selecting items from the menu screen allows easy programming. Using the engineering port, you can easily set up the parameters by using the parameter programming software [PASS] through a personal computer, too.

● Operation records by contact input

By the optional mathematical function, contact input can be inputted through input terminals. Furthermore, by adding the optional remote contacts function, contact input can be inputted through the remote contacts terminals in addition to analog inputs.

● Data management by message function

Messages (maximum 30 alpha-numeric characters) can be written on the trend screen. Up to 10 kinds of message can be pre-registered and written by the keyboard, communications or remote contacts. The message can be written on the historical trend screen, too.

● Package software

The data acquisition software package [KIDS] and the parameter programming software package [PASS] are optionally prepared for easy data management by your personal computer.

■ MODELS

BR17□□-□□□

Input point, Input speed

- 61 : Standard 6 points (6-point/ 5-second)
- B2: Standard 12 points (12-point/ 2 second)
- 13 : Continuous (1-point/ 0.1-second)
- 33 : Continuous (3-point/ 0.1-second)

A2 : Standard 6 points (6-point/ 1-second)

23 : Continuous (2-point/ 0.1-second)

43 : Continuous (4-point/ 0.1-second)

Communications interface (option)

- N : None
- R : RS-232C (high-order)
- E : Ethernet (high-order)
- [2-port communications]
- B : RS-422A (high-order) + RS-422A (low-order)
- P : RS-232C (high-order) + RS-422A (low-order)
- T : RS-485 (high-order) + RS-422A (low-order)
- G : Ethernet (high-order) + RS-422A (low-order)
- A : RS-422A (high-order)
- S : RS-485 (high-order)
- C : RS-422A (high-order) + RS-485 (low-order)
- Q : RS-232C (high-order) + RS-485 (low-order)
- U : RS-485 (high-order) + RS-485 (low-order)
- H : Ethernet (high-order) + RS-485 (low-order)

Alarm output/remote contacts (option)

- 0 : None
- 1 : 6 (MOS relay) alarm outputs + remote contacts
- 2 : 6 (Form C mechanical relay) alarm outputs* + remote contacts
(Not conforming to CE, UL, and CSA)
- A : 6 (Form A mechanical relay) alarm outputs + remote contacts

Memory

- 1 : FDD + internal memory 3MB (standard)
- 2 : Memory card + internal memory 3MB (option)

■ INPUT SPECIFICATIONS

Number of measuring points:

- 6, 12 points(Standard input)
- 1 to 4 points(Continuous input)

Input signals:

- Universal input
- DC voltage 10 kinds, Thermocouple 36 kinds
- Resistance thermometer 11 kinds, DC current (by shunt resistors)

Range setup:

- Programming of input types and ranges by keys
- The gain is automatically selected by the range programmed.

Scale setup:

- Programming of maximum values, minimum values and engineering units by keys

Accuracy ratings:

- Refer to the table of inputs.

Measuring cycle:

- Standard input: 5 seconds/6 points,
- 1 second/6 points, 2 seconds/12 points
- Continuous input: 0.1 second/4 points

Reference junction compensation accuracy:

- K, E, J, T, N, Platinel $\pm 0.5^{\circ}\text{C}$ or lower
- R, S, NiMo-Ni, CR-AuFe, WRe5-WRe26
- W-WRe26, U, L $\pm 1.0^{\circ}\text{C}$ or lower
- (The above errors are added to the accuracy ratings for the internal reference junction compensation.)

Input resolution:

- About 1/56000 (converted into reference ranges)

Burnout:

- Detection of signal disconnection for thermocouple inputs and resistance thermometer inputs
- Up-scale burnout, down-scale burnout or burnout disabled is selectable for each input.

Allowable signal source resistance:

- Thermocouple input (burnout disable)/
- DC voltage input ($\pm 2\text{V}$ or lower) 1k Ω or lower
- DC voltage input ($\pm 5\text{V}$ to $\pm 50\text{V}$) 100 Ω or lower
- Resistance thermometer input (Pt100, JPt100)
- 10 Ω or lower per wire
- (3 wires: same resistance)

Input resistance:

- Thermocouple inputs ... About 8M Ω
- DC voltage inputs $\pm 2\text{V}$ or lower: About 8M Ω
- $\pm 5\text{V}$ to $\pm 50\text{V}$: About 1M Ω

Maximum applied input voltage:

- Thermocouple input (burnout disable)/
- DC voltage input ($\pm 2\text{V}$ or lower) ... Max. $\pm 10\text{VDC}$
- DC voltage input ($\pm 5\text{V}$ to 50V) Max. $\pm 60\text{VDC}$
- Thermocouple input (burnout enable)/
- Resistance thermometer input Max. $\pm 6\text{VDC}$

Input correction:

- Zero, span and shift adjustments for each channel

Maximum common mode voltage:

- 30VAC

Common mode rejection ratio:

- 120dB or more (50 or 60Hz)

Series mode rejection ratio:

- 50dB or more (50 or 60Hz)

- Under the condition that the peak value including signal equals or is lower than 1.5 times of a reference range

■ DISPLAY SPECIFICATIONS

Display:

5.5" TFT color LCD
(320 x 240 dots:111.36mm x 83.52mm)

Trend display colors:

10 colors (selectable)

Operation screens:

Screens are switched by scroll key and entry key.
Max. 5 groups except alarm summary screen can be switched and displayed. (Max. 6 channels/group)

- Trend screens (with scale plate and pointer displays)...

Selects from real-time trend, historical trend and dual trend screens.

Vertical or horizontal time scale orientation selectable

Data display enable or disable selectable

Scrolling available

Zone recording

Compressed/expanded recording

- Bargraph screen ...

Data display enable or disable selectable

- Data screen (Data + Tag + Engineering unit + Alarm activation status)

- Multi-screen ...

Real-time trend screen + Bargraph screen + Data screen

- Alarm summary screen ...

Current alarm output status and alarm activation/reset log

(channel, level, alarm activation/reset time)

Skip function (Trend and Data screens):

The channels to be skipped in display can be programmed for each group.

Scroll function:

Referring to historical data by the cursor is enabled on the trend screen.

- Real-time trend ...

Scroll measuring count

= $131072 / (\text{Number of data channels} + 2)$

About 5 hours 12 minutes

- Historical trend ...

Entire memory file area

- Dual trend ...

Enables on the historical trend screen only.

Replay (Historical trend):

Historical data is displayed by specifying a file.
Data logging is continued.

- * Replays by the scrolling function or by time specified.

- * Enables to replay from a floppy disk.

Data search function (Historical trend):

The trend display position matching the following conditions is searched automatically from the data in the replay file and the cursor is moved to the position.

- Channel A data = Channel B data
- Channel A data < Channel B data
- Channel A data < Data specified (optional programming)
- Data of Channel A > Data specified (optional programming)
- Data 1 specified (optional programming) =< Data of Channel A =< Data 2 specified (optional programming)

Message display:

Displays messages on the trend screen by keys or by remote contacts signal and stores them as a message data file (maximum 200 messages).

Enables to display and stores them on the historical trend screen.

- * Messages can be pre-stored. (maximum 10 messages, maximum 30 characters/message)

- * On the horizontal time scale, maximum 10 characters/message can be displayed.

Display updating interval:

Trend screen ...

Depended on time scale programmed

Minimum 1 second

Data screen ...

Standard input: About 1 second

Continuous input: Measuring cycle

Time scale programming:

Programs interval of displaying dots on the time scale.

0.1, 0.2, 0.5, 1, 2, 3, 5, 10, 15, 20, 30 seconds

1, 2, 3, 5, 10, 15, 20, 30, 60 minutes

LCD saver:

When no key is operated for the specified period of time, the backlight is dimmed and the screen saver display appears.

Programmable period: 1 to 60 minutes

(Note)

The LCD display may contain some pixels that always or never illuminate, and the brightness of some areas of the display may appear uneven. These are typical LCD performance characteristics and do not constitute malfunctions.

■ MEMORY FUNCTION

Internal memory: 3MB

Storing interval:

- 0.1, 0.2, 0.5, 1, 2, 3, 5, 10, 15, 20, 30 seconds
- 1, 2, 3, 5, 10, 15, 20, 30, 60 minutes

Storing data:

Measured data (Maximum 5 files on simultaneous storage), Message (1 file), Alarm activation/reset (1 file), Programmed parameters (1 file)

- Measured data ...
File number, Storage start date/time, Storage interval, Scale data, Measured data
- Message ...
Time, Message text (Max. 200 messages)
- Alarm activation/reset ...
Alarm activation/reset time, Channel, Level, Alarm type (Maximum 200 information)
- Programmed parameters ...
Storage date/time, all parameters (Updated at reprogramming)

Measured data stored:

2-bite binary/1 data

- * Stores both minimum values and maximum values in case that the storing interval is longer than the measuring interval.

Storage into internal memory:

- * Selection from the followings by keys
 - Key operation
 - Trigger signal (Remote contacts, Alarm activation)
 - Storage during conductive signal ON
 - Start/end by time
- * Pre-triggering storage available for key operation and triggering signals.
 - Pre-triggering measuring count
= $65536 / (\text{Number of data channels} + 2)$
- * The storage channel and storage interval can be programmed for each file.
- * Memory allocation enables simultaneous-writing to multiple files (max. 5 files).
[The memory can be divided into 52 blocks and each storage block can be allocated to a file.]
- * A file closes when it has been fully written. (The storage to the specified file ends.)

Status output:

When 90% of the storage space in a file has been written, the status can be output at alarm output terminals.

Memory usage display:

The amount (%) of memory used in each file is displayed on the operation screens.

External memory medium:

3.5" floppy disk (2HD: 1.44MB MS-DOS formatted)
ATA flash memory card (FAT16 format), Max 96MB (Option) *Data in internal memory can be copied to a floppy disk or memory card by keys. Automatic writing function is available for memory card type.

■ PROGRAMMING/OPERATION

Keys: 1, 2, 3, 4, 5, 6, scroll key, and entry key

Operator programming:

- Message programming (executing on the trend screens: Storing and execution of 10 messages)
- Channel parameters (input ranges, others)
- Maths-related parameters
- Alarm-related parameters
- Date/time programming

Engineering parameters programming:

- Channel parameters (input ranges, others)
- Maths-related parameters
- Alarm-related parameters
- Date/time programming and date format selection
(Date format: YY/MM/DD, MM/DD/YY, DD/MM/YY)
- Daylite savings time selection
- Password registration/cancellation
- Programming guidance language selection (English/Japanese)
- Screen saver-related programming
- Screen brightness
- Display group registration (page switching, max. 6 channels/screen)
- Operation screen enable/disable registration
- Trend screen registration (Time scale vertical/horizontal direction, Black/white screen color selection, Display format programming: Compressed/expanded display, zone)
- File registration (Registration of data logging conditions)
- Message programming (max. 10 messages)
- User access programming
- Allocation programming of remote contacts input
- Allocation programming of status output
- Communications parameters
- Scale calibration (zero/span adjustment, shift adjustment)
- Memory initialization
- Hardware check

Floppy disk operation:

- Formatting
- Data file copy from internal memory
- Read/write of programmed parameters

■ ALARM SPECIFICATIONS

Alarm levels: Maximum 4 levels/channel

Alarm types:

High alarm, low alarm, differential high alarm, differential low alarm, rate-of-change increase alarm, rate-of-change decrease alarm

Alarm storage:

Storage of alarm activation/reset time and alarm types

* Storage of latest 200 data common to channels

Alarm output (option): 6 points (AND/OR output possible)

* The memory status output and fail output can be programmed to alarm output terminals.

■ GENERAL SPECIFICATIONS

Rated power voltage:

100 to 240VAC, 50/60Hz

Power consumption:

Maximum 45VA

Power failure protection:

Programmed parameters stored into EEPROM memory. Data stored into flash memory

Clock circuit and data sustained for minimum 6 years by a lithium battery (at the operation more than 8 hours/day)

Environmental conditions:

- Reference operating condition ...
 - Ambient temperature/humidity range: 21 to 25°C, 45 to 65%RH
 - Power voltage: 100VAC ± 1%
 - Power frequency: 50/60Hz ± 0.5%
 - Attitude: Left/right 0°, Forward tilting 0°, Backward tilting 0°
 - Warm-up time: 1 hour or longer
- Normal operating condition ...
 - Ambient temperature/humidity range: 0 to 50°C, 20 to 80%RH
 - * On using a floppy disk ... 5 to 40°C
 - * Max temp. on using memory card (Option) (Max temp. for using memory card -10°C)
 - Power voltage: 90 to 264VAC
 - Power frequency: 50/60Hz ± 2%
 - Attitude: Left/right 0°, Forward tilting 0°, Backward tilting 0 to 20°
- Transportation condition ...
 - In the packed condition on shipment from our factory
 - Ambient temperature/humidity range: -20 to 60°C, 5 to 90%RH (No dew condensation)
 - Vibration: 10 to 60Hz, 0.5G or lower
 - Impact: 40G or lower
- Storage condition ...
 - Ambient temperature/humidity range: -20 to 60°C, 5 to 90%RH (No dew condensation)

Insulation resistance:

Between secondary terminals and protective conductor terminal .. More than 20MΩ at 500VDC

Between primary terminals and protective conductor terminal .. More than 20MΩ at 500VDC

Between primary terminals and secondary terminals More than 20MΩ at 500VDC

Between alarm output terminals (mechanical relay) and other secondary terminals ...

More than 20MΩ at 500VDC

Note: Primary terminals:

Power (L, N), Alarm output (MOS relay, Form A mechanical relay)

Secondary terminals:

Input, Alarm output (Form C mechanical relay), Remote contacts, Communications

Dielectric strength:

Between secondary terminals and protective conductor terminal 1 minute at 500VAC

Between primary terminals and protective conductor terminal 1 minute at 1500VAC

Between primary terminals and secondary terminals 1 minute at 2300VAC

Between alarm output terminals (mechanical relay) and other secondary terminals ...

1 minute at 1000VAC

Note: Primary terminals:

Power (L, N), Alarm output (MOS relay, Form A mechanical relay)

Secondary terminals:

Input, Alarm output (Form C mechanical relay), Remote contacts, Communications

Case assembly material:

Door frame ... ABS resin

Enclosure ... Steel

Color:

Door ... Black (frame - equivalent to Munsell N3.0), Transparent (front plate)

Enclosure Gray (equivalent to Munsell N7.0)

Weight:

About 3.2kg

Mounting:

Panel mounting

Clock accuracy:

±2 minutes per 30 days (except error by power supply ON/OFF under the reference operation conditions)

Terminal screws:

Power terminals M4.0

Protective conductor terminal M4.0

Measuring input terminals M3.5

Alarm output terminals M3.5

Remote contacts signal terminals M3.5

Communications terminals M3.5

INTERNATIONAL SAFETY STANDARDS

CE: EN55011 Group1 Class A
 EN-50082-2
 EN61010-1 + A2
 IP: IEC529 IP54 (front part)

UL: UL3111-1
 CSA (C-UL): C22.2, No.1010

OPTIONS

Options	Specifications
Remote contacts/alarm output	<p>The following operations are available by contact input (4 points) and common (2 points) signal. (parameter connection)</p> <p>(1) Data memory triggering When the conduct signal is changed to ON from OFF, the data storage into the internal memory starts.</p> <p>(2) Data memory signal During ON of the conduct signal, the data is stored into the internal memory.</p> <p>(3) Message display When the conduct signal is changed to ON from OFF, pre-registered message is displayed.</p> <p>(4) Totalizing reset Reset of the totalizing data (All channels together)</p>
	<p>Alarm output points: 6 points (OR output possible) Contact rating: MOS relay output ... 240V (AC, DC) 50mA irrespective of load types Mechanical relay output (common to Form A and Form C) ... 100VAC 0.5A resistive load 240VAC 0.2A resistive load 100VDC 0.3A resistive load * Form C mechanical relay output: Not conforming to CE, UL, and CSA</p>
Mathematics	<p>The following maths-function can be executed to the measured data. The maths-function can be also executed to the calculated data.</p> <p>(1) Arithmetic (2) Square root (3) Logarithm, Natural Logarithm (4) Exponential (5) Maximum, minimum. Average (6) Temperature/humidity (7) Operation record (input, remote contacts)</p>
Memory card	<p>A PCMCIA ATA flash memory card is used as an external storage media. The files stored into the internal memory are automatically stored into the memory card.</p>

Options	Specifications
Communications	<p>RS-232C, RS-422A, RS-485 or Ethernet (to be specified) RS-232C, RS-422A, RS-485: MODBUS protocol (RTU/ASCII) Functions: Data transmission, Parameter programming, Operation, Data communications input, Low-order communications programming* [Ethernet: Data transmission, Parameter programming (some part)] * By using 1-port communications, low-order communications is available.</p>
2-port communications	<p>High-order communications: Refer to the above Low-order communications: By connecting with CHINO's instruments (as slave instruments – up to 5 sets), BR (master instrument) can collect data from slave instruments and program "input kind", "RJ", and "burnout". When controllers are connected as slave instruments, collection of "PV, SV, and MV values" data is possible.</p> <ul style="list-style-type: none"> • Low-order communications: RS-422A or RS-485 (to be specified) MODBUS protocol (RTU/ASCII) • Instruments: Recorders ... BR1000, AL3000, AH3000 Controllers ... DZ1000, DZ2000
Totalizer	<p>Totalizing measured data or calculated data Interval: 1 minute to 24 hours or no interval Start time: 0 hr. 0 min. to 23 hr. 59 min.</p>
Daily report file	<p>Creates a daily report file by specifying channels, time (optional time, max. 24 points) and the following items. Instant vale Maximum value in block Minimum value in block Average value in block Maximum value in day Minimum value in day Average value in day</p>
Shunt resistor for current input	<p>For measuring current by adding 250Ω or 20Ω</p>

MEASURING RANGES/ACCURACY RATING/DISPLAY RESOLUTION

The accuracy ratings are under the reference operating condition.
 For thermocouple inputs, the accuracy of reference junction compensation is not included with the accuracy ratings.
 The indication equivalent to maximum 2mV or 25°C may vary under the test environment by EMC directives.

[Reference operating condition] Ambient temperature/humidity range: 21 to 25°C, 45 to 65%RH
 Power voltage: 100VAC ± 1%
 Power frequency: 50/60Hz ± 0.5%
 Attitude: Left/right 0°, Forward tilting 0°, Backward tilting 0°
 Warm up time: 1 hour or longer

Input kinds	Measuring ranges	Ref. ranges	Accuracy ratings	Display resolution
Thermocouple	K	-200.0 to 300.0°C	±13.8mV	0.1°C
		-200.0 to 600.0°C	±27.6mV	0.1°C
		-200 to 1370°C	±69.0mV	1°C
	E	-200.0 to 200.0°C	±13.8mV	0.1°C
		-200.0 to 350.0°C	±27.6mV	0.1°C
		-200 to 900°C	±69.0mV	1°C
	J	-200.0 to 250.0°C	±13.8mV	0.1°C
		-200.0 to 500.0°C	±27.6mV	0.1°C
		-200 to 1200°C	±69.0mV	1°C
	T	-200.0 to 250.0°C	±13.8mV	0.1°C
		-200.0 to 400.0°C	±27.6mV	0.1°C
	R	0 to 1200°C	±13.8mV	1°C
		0 to 1760°C	±27.6mV	1°C
	S	0 to 1300°C	±13.8mV	1°C
		0 to 1760°C	±27.6mV	1°C
	B	0 to 1820°C	±13.8mV	1°C
	N	-200.0 to 400.0°C	±13.8mV	0.1°C
		-200.0 to 750.0°C	±27.6mV	0.1°C
		-200 to 1300°C	±69.0mV	1°C
	W-WRe26	0 to 2315°C	±69.0mV	1°C
WRe5-WRe26	0 to 2315°C	±69.0mV	1°C	
PtRh20-PtRh5	0 to 1800°C	±13.8mV	1°C	
PtRh40-PtRh20	0 to 1888°C	±13.8mV	1°C	
NiMo-Ni	-50.0 to 290.0°C	±13.8mV	0.1°C	
	-50.0 to 600.0°C	±27.6mV	0.1°C	
	-50 to 1310°C	±69.0mV	1°C	
CR-AuFe	0.0 to 280.0 K	±13.8mV	0.1 K	
Platinel II	0.0 to 350.0°C	±13.8mV	0.1°C	
	0.0 to 650.0°C	±27.6mV	0.1°C	
	0 to 1395°C	±69.0mV	1°C	
U	-200.0 to 250.0°C	±13.8mV	0.1°C	
	-200.0 to 500.0°C	±27.6mV	0.1°C	
	-200.0 to 600.0°C	±69.0mV	0.1°C	
L	-200.0 to 250.0°C	±13.8mV	0.1°C	
	-200.0 to 500.0°C	±27.6mV	0.1°C	
	-200 to 900°C	±69.0mV	1°C	

K, E, J, T, R, S, B, N: IEC584, JIS C1602-1995
 U (Cu-CuNi), L (Fe-CuNi): DIN43710
 W-WRe26, WRe5-WRe26, PtRh20-PtRh5, PtRh40-PtRh20, NiMo-Ni, CR-AuFe, Platinel II: ASTM

Input kinds	Measuring ranges	Ref. ranges	Accuracy ratings	Display resolution	
DC voltage	-13.80 to 13.80mV	±13.8mV	±0.1% ± 1 digit	10μV	
	-27.60 to 27.60mV	±27.6mV		10μV	
	-69.00 to 69.00mV	±69.0mV		10μV	
	-200.0 to 200.0mV	±200.0mV		100μV	
	-500.0 to 500.0mV	±500.0mV		100μV	
	-2.000 to 2.000V	±2V		1mV	
	-5.000 to 5.000V	±5V		1mV	
	-10.00 to 10.00V	±10V		10mV	
	-20.00 to 20.00V	±20V		10mV	
	-50.00 to 50.00V	±50V		10mV	
Resistance thermometer	Pt100 (1)	-140.0 to 150.0°C	160Ω	±0.15% ± 1 digit	0.1°C
		-200.0 to 300.0°C	220Ω	±0.1% ± 1 digit	0.1°C
		-200.0 to 850.0°C	400Ω	±1 digit	0.1°C
	Pt100 (2)	-140.0 to 150.0°C	160Ω	±0.15% ± 1 digit	0.1°C
		-200.0 to 300.0°C	220Ω	±0.1% ± 1 digit	0.1°C
		-200.0 to 649.0°C	400Ω	±1 digit	0.1°C
	JPt100	-140.0 to 150.0°C	160Ω	±0.15% ± 1 digit	0.1°C
		-200.0 to 300.0°C	220Ω	±0.1% ± 1 digit	0.1°C
		-200.0 to 649.0°C	400Ω	±1 digit	0.1°C
	Pt50	-200.0 to 649.0°C	220Ω	±0.1% ± 1 digit	0.1°C
		-200.0 to 649.0°C	400Ω	±1 digit	0.1°C
	Pt-Co	4.0 to 374.0K	220Ω	±0.15% ± 1 digit	0.1 K

Pt100 (1): IEC751 (1995), JIS C1604-1997
 Pt100 (2): IEC751 (1983), JIS C1604-1989, JIS C1606-1989,
 JPt100: JIS C1604-1981, JIS C1606-1989,

EXCEPTION OF ACCURACY RATINGS

Input kinds	Measuring range	Accuracy rating
K, E, J, T, L	-200 to 0°C	±0.2% ± 1 digit
R, S	0 to 400°C	±0.2% ± 1 digit
B	0 to 400°C	Not specified
	400 to 800°C	±0.15% ± 1 digit
N, U	-200 to 0°C	±0.3% ± 1 digit
W-WRe26	0 to 100°C	±4% ± 1 digit
	100 to 400°C	±0.5% ± 1 digit
PtRh20-PtRh5	0 to 100°C	±4% ± 1 digit
	100 to 400°C	±0.5% ± 1 digit
PtRh40-PtRh20	0 to 300°C	±1.5% ± 1 digit
	300 to 800°C	±0.8% ± 1 digit
CR-AuFe	0 to 20 K	±0.5% ± 1 digit
	20 to 50 K	±0.3% ± 1 digit
Pt100 (1)	700 to 850°C	±0.15% ± 1 digit
Pt-Co	4 to 50 K	±0.3% ± 1 digit

■ TERMINAL ARRANGEMENT

MOS relay type, Mechanical relay "a" contact type

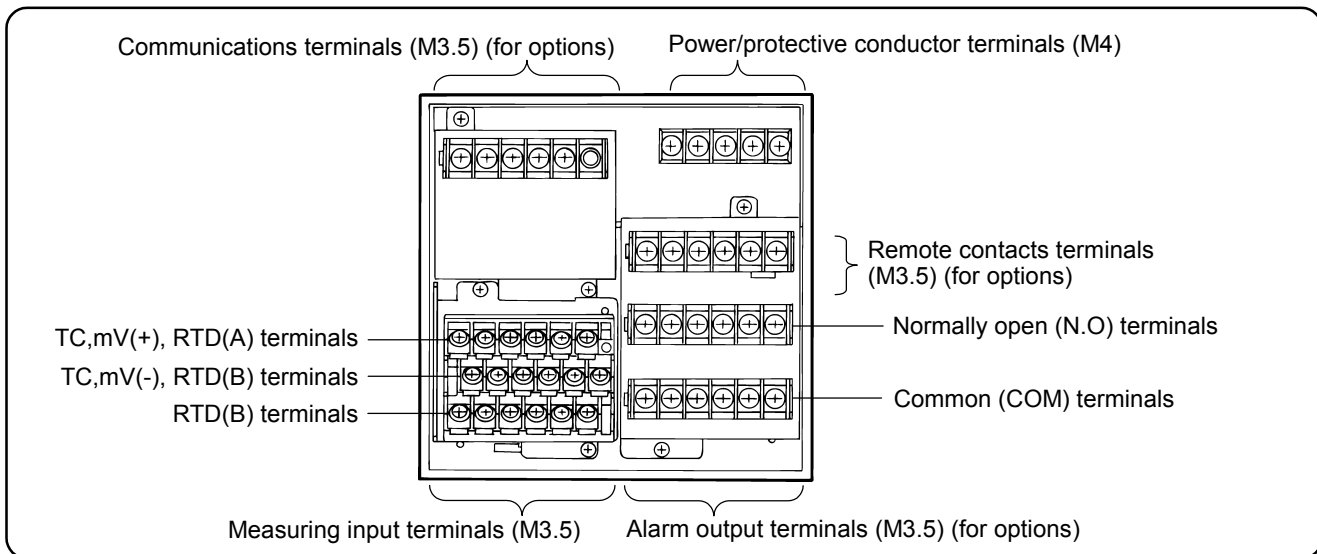

Mechanical relay "c" contact type

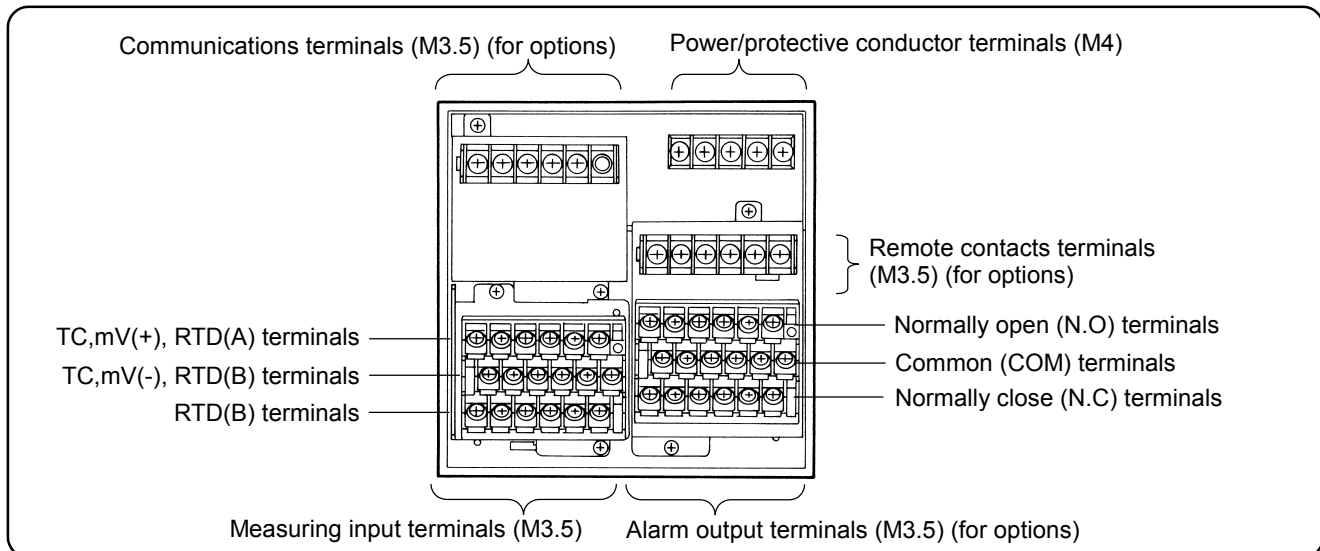

12 points input type

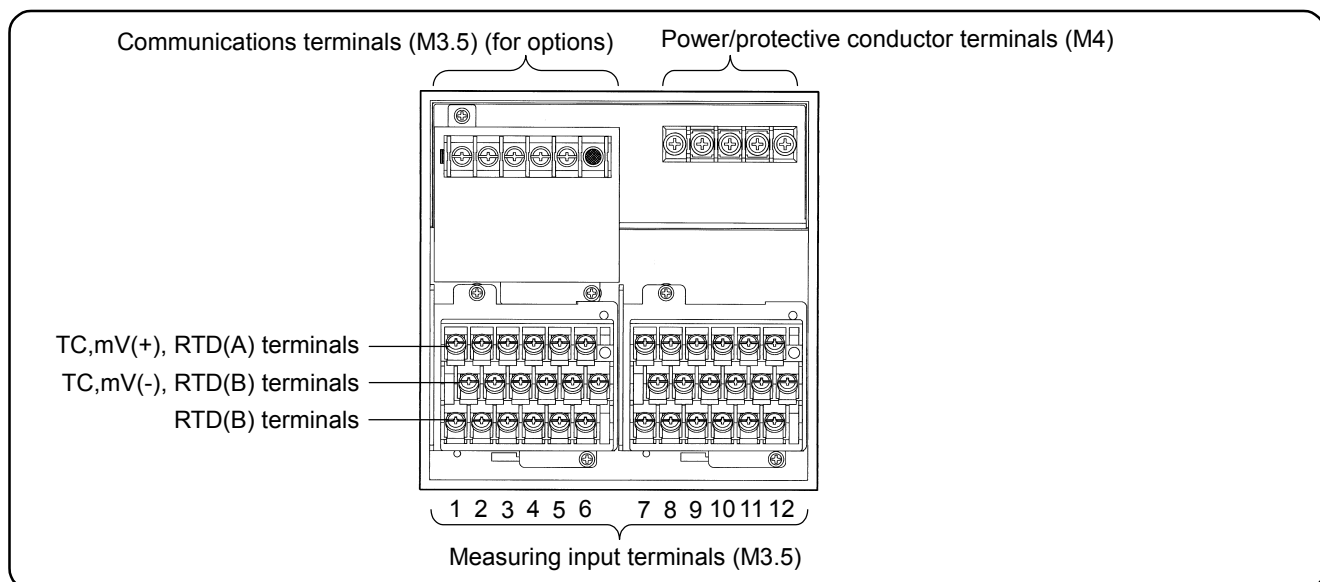

Alarm output / remote contacts option for 12 points input type

The option of the alarm output/remote contacts is attached as a separate unit as shown in the figures.

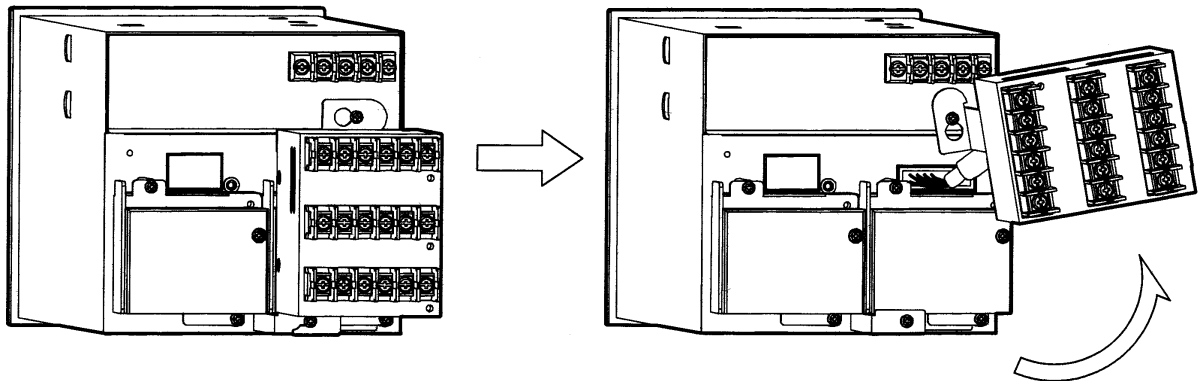

The connections of input is executed by turning the alarm terminal block (including the remote contacts terminal block).

■ DIMENSIONS

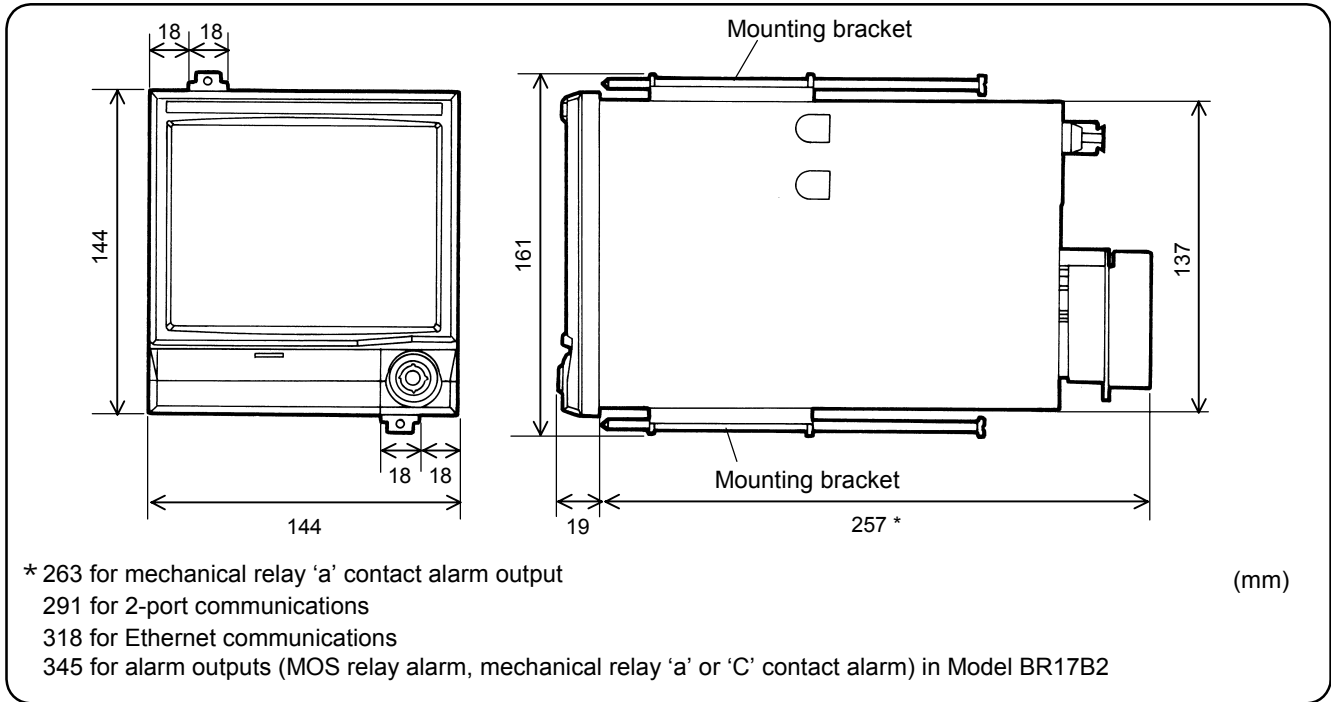

■ PANEL CUTOUT AND MINIMUM CLEARANCE

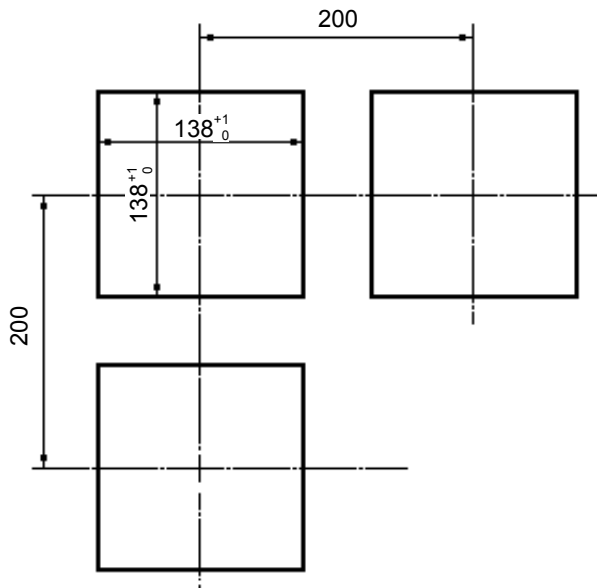

Unit: mm

Specifications subject to change without notice. Printed in Japan (I) 2003. 7

CHINO CORPORATION

32-8, KUMANO-CHO, ITABASHI-KU, TOKYO 173-8632

PHONE: +81-3-3956-2171

FAX: +81-3-3956-0915

E-mail: inter@chino.co.jp

Website: <http://www.chino.co.jp>